



SERVICE STATION MANUAL

854304



BREVA V1100



SERVICE STATION MANUAL

BREVA V1100

While the basic features as described and illustrated in this manual remain unchanged, **Moto Guzzi** s.p.a. reserves the right to introduce changes to their own models at any time. All rights regarding electronic data storage, total or partial reproduction or adaptation of this manual by any means are reserved for all Countries. Third party products or services referred to in this manual should be considered only informative and are not binding. Moto Guzzi s.p.a. shall not be liable for any functions or use of these products.

SERVICE STATION MANUAL

BREVA V1100

This manual provides the main information to carry out regular maintenance operations on your scooter. This manual is intended to **Moto Guzzi Dealers** and their qualified mechanics; several concepts have been deliberately omitted as they are considered unnecessary. As it is not possible to include complete mechanical notions in this manual, users should have basic mechanical knowledge or minimum knowledge about the procedures involved when repairing scooters. Without this knowledge, repairing or checking the vehicle may be inefficient or even dangerous. As the vehicle repair and check procedures are not described in detail, be extremely cautious so as not to damage components or injure individuals. In order to optimise customer satisfaction when using our vehicles, **Moto Guzzi s.p.a.** commits itself to continually improve its products and the relative documentation. The main technical modifications and changes in repair procedures are communicated to all **Moto Guzzi Sales Outlets and its International Subsidiaries**. These changes will be introduced in the subsequent editions of the manual. In case of need or further queries on repair and check procedures, consult **Moto Guzzi CUSTOMER DEPARTMENT**, which will be prepared to provide any information on the subject and any further communications on updates and technical changes related to the vehicle.

NOTE Provides key information to make the procedure easier to understand and carry out.

CAUTION Refers to specific procedures to carry out for preventing damages to the vehicle.

WARNING Refers to specific procedures to carry out to prevent injuries to the repairer.



Personal safety Failure to completely observe these instructions will result in serious risk of personal injury.



Safeguarding the environment Sections marked with this symbol indicate the correct use of the vehicle to prevent damaging the environment.



Vehicle intactness The incomplete or non-observance of these regulations leads to the risk of serious damage to the vehicle and sometimes even the invalidity of the guarantee



INDEX OF TOPICS

CHARACTERISTICS

CHAR

SPECIAL TOOLS

S-TOOLS

MAINTEENANCE

MAIN

ELECTRICAL SYSTEM

ELE SYS

ENGINE FROM VEHICLE

ENG VE

ENGINE

ENG

POWER SUPPLY

P SUPP

SUSPENSIONS

SUSP

CHASSIS

CHAS

BRAKING SYSTEM

BRAK SYS

BODYWORK

BODYW

PRE-DELIVERY

PRE DE

INDEX OF TOPICS

CHARACTERISTICS

CHAR

Rules

Safety rules

Carbon monoxide

If you need to keep the engine running while working on the vehicle, please ensure that you do so in an open or very well ventilated area. Never run the engine in an enclosed area. If you do work in an enclosed area, make sure to use a fume extraction system.

CAUTION



EXHAUST EMISSIONS CONTAIN CARBON MONOXIDE, A POISONOUS GAS WHICH CAN CAUSE LOSS OF CONSCIOUSNESS AND EVEN DEATH.

Fuel

CAUTION



**THE FUEL USED TO POWER INTERNAL COMBUSTION ENGINES IS HIGHLY FLAMMABLE AND MAY BE EXPLOSIVE UNDER CERTAIN CONDITIONS. IT IS THEREFORE RECOMMENDED TO CARRY OUT REFUELLING AND MAINTENANCE PROCEDURES IN A VENTILATED AREA WITH THE ENGINE SWITCHED OFF. DO NOT SMOKE DURING REFUELLING AND NEAR FUEL VAPOURS, AVOIDING ANY CONTACT WITH NAKED FLAMES, SPARKS OR OTHER SOURCES WHICH MAY CAUSE THEM TO IGNITE OR EXPLODE.
DO NOT DISPERSE FUEL IN THE ENVIRONMENT.
KEEP OUT OF THE REACH OF CHILDREN**

Hot components

The engine and the exhaust system components become very hot and remain hot for some time after the engine has been switched off. When handling these components, wear insulating gloves or wait until the engine and the exhaust system have cooled down.

Used engine oil and transmission oil

CAUTION



**IT IS ADVISABLE TO WEAR PROTECTIVE IMPERMEABLE GLOVES WHEN SERVICING THE VEHICLE.
THE ENGINE OR GEARBOX OIL MAY CAUSE SERIOUS INJURIES TO THE SKIN IF HANDLED FOR PROLONGED PERIODS OF TIME AND ON A REGULAR BASIS.
WASH YOUR HANDS CAREFULLY AFTER HANDLING OIL.
HAND THE OIL OVER TO OR HAVE IT COLLECTED BY THE NEAREST USED OIL RECYCLING COMPANY OR THE SUPPLIER.
DO NOT DISPOSE OF OIL IN THE ENVIRONMENT
KEEP OUT OF THE REACH OF CHILDREN**

Brake and clutch fluid



BRAKE AND CLUTCH FLUIDS CAN DAMAGE THE PLASTIC OR RUBBER PAINTED SURFACES. WHEN SERVICING THE BRAKING SYSTEM OR THE CLUTCH SYSTEM, PROTECT THESE COMPONENTS WITH A CLEAN CLOTH. ALWAYS WEAR PROTECTIVE GOGGLES WHEN SERVICING THESE SYSTEMS. BRAKE AND CLUTCH FLUIDS ARE EXTREMELY HARMFUL FOR YOUR EYES. IN THE EVENT OF ACCIDENTAL CONTACT WITH THE EYES, RINSE THEM IMMEDIATELY WITH ABUNDANT COLD, CLEAN WATER AND SEEK MEDICAL ADVICE. KEEP OUT OF THE REACH OF CHILDREN

Battery electrolyte and hydrogen gas

CAUTION



THE BATTERY ELECTROLYTE IS TOXIC, CORROSIVE AND AS IT CONTAINS SULPHURIC ACID, IT CAN CAUSE BURNS WHEN IN CONTACT WITH THE SKIN. WHEN HANDLING BATTERY ELECTROLYTE, WEAR TIGHT-FITTING GLOVES AND PROTECTIVE APPAREL. IN THE EVENT OF SKIN CONTACT WITH THE ELECTROLYTIC FLUID, RINSE WELL WITH PLENTY OF CLEAN WATER. IT IS PARTICULARLY IMPORTANT TO PROTECT YOUR EYES BECAUSE EVEN TINY AMOUNTS OF BATTERY ACID MAY CAUSE BLINDNESS. IF THE FLUID GETS IN CONTACT WITH YOUR EYES, WASH WITH ABUNDANT WATER FOR FIFTEEN MINUTES AND CONSULT AN EYE SPECIALIST IMMEDIATELY. THE BATTERY RELEASES EXPLOSIVE GASES; KEEP IT AWAY FROM FLAMES, SPARKS, CIGARETTES OR ANY OTHER HEAT SOURCES. ENSURE ADEQUATE VENTILATION WHEN SERVICING OR RECHARGING THE BATTERY. KEEP OUT OF THE REACH OF CHILDREN BATTERY LIQUID IS CORROSIVE. DO NOT POUR IT OR SPILL IT, PARTICULARLY ON PLASTIC COMPONENTS. ENSURE THAT THE ELECTROLYTIC ACID IS COMPATIBLE WITH THE BATTERY TO BE ACTIVATED.

Maintenance rules

GENERAL PRECAUTIONS AND INFORMATION

When repairing, dismantling and reassembling the vehicle, follow the recommendations given below carefully.

BEFORE DISASSEMBLING COMPONENTS

- Before dismantling components, remove dirt, mud, dust and foreign bodies from the vehicle. Use the special tools designed for this bike, as required.

COMPONENTS REMOVAL

- Do not loosen and/or tighten screws and nuts using pliers or any other tools than the specific wrench.
- Mark positions on all connection joints (pipes, cables etc.) before separating them, and identify them with distinctive symbols.
- Each component needs to be clearly marked to enable identification during reassembly.
- Clean and wash the dismantled components carefully using a low-flammability detergent.
- Keep mated parts together since they have "adjusted" to each other due to normal wear.

- Some components must be used together or replaced completely.
- Keep away from heat sources.

REASSEMBLING COMPONENTS

CAUTION

BEARINGS MUST ROTATE FREELY, WITHOUT JAMMING AND/OR NOISE, OTHERWISE, THEY NEED TO BE REPLACED.

- Only use ORIGINAL Moto Guzzi SPARE PARTS.
- Comply with lubricant and consumables use guidelines.
- Lubricate parts (whenever possible) before reassembling them.
- When tightening nuts and screws, start from the ones with the largest section or from the internal ones, moving diagonally. Tighten nuts and screws in successive steps before applying the tightening torque.
- Always replace self-locking nuts, washers, sealing rings, circlips, O-rings (OR), split pins and screws with new ones if their tread is damaged.
- When assembling the bearings, make sure to lubricate them well.
- Check that each component is assembled correctly.
- After a repair or routine maintenance procedure, carry out pre-ride checks and test the vehicle on private grounds or in an area with low traffic density.
- Clean all coupling surfaces, oil guard rims and gaskets before refitting them. Smear a light layer of lithium-based grease on the oil guard rims. Reassemble oil guards and bearings with the brand or lot number facing outward (visible side).

ELECTRICAL CONNECTORS

Electric connectors must be disconnected as described below; failure to comply with this procedure causes irreparable damage to both the connector and the wiring harness:

Press the relative safety clips, if applicable.

- Grip the two connectors and disconnect them by pulling them in opposite directions.
- If any signs of dirt, rust, moisture, etc. are noted, clean the inside of the connector carefully with a jet of compressed air.
- Ensure that the cables are correctly fastened to the internal connector terminals.
- Then connect the two connectors, ensuring that they couple correctly (if fitted with clips, you will hear them "click" into place).

CAUTION

DO NOT DISCONNECT CONNECTORS BY PULLING THE CABLES.

NOTE

THE TWO CONNECTORS CAN ONLY BE CONNECTED IN ONE DIRECTION: CONNECT THEM THE RIGHT WAY ROUND.

TIGHTENING TORQUES

CAUTION

REMEMBER THAT THE TIGHTENING TORQUES FOR ALL FASTENING ELEMENTS ON WHEELS, BRAKES, WHEEL AXLES AND ANY OTHER SUSPENSION COMPONENTS PLAY A KEY ROLE IN ENSURING VEHICLE SAFETY AND MUST COMPLY WITH SPECIFIED VALUES. CHECK THE

TIGHTENING TORQUES OF FASTENING ELEMENTS ON A REGULAR BASIS AND ALWAYS USE A TORQUE WRENCH TO REASSEMBLE THESE COMPONENTS. FAILURE TO COMPLY WITH THESE RECOMMENDATIONS MAY CAUSE ONE OF THESE COMPONENTS TO LOOSEN OR EVEN DETACH, CAUSING A WHEEL TO LOCK OR COMPROMISING VEHICLE HANDLING. THIS MAY LEAD TO FALLS, WITH THE RISK OF SERIOUS INJURY OR DEATH.

Running-in

Running the engine in correctly is essential for ensuring engine longevity and functionality. Twisty roads and gradients are ideal for running in the engine, brakes and suspension effectively. Vary your riding speed during the running in period. This ensures that components operate in "loaded" conditions and then "unloaded" conditions, allowing the engine components to cool.

CAUTION

THE CLUTCH MAY EMIT A SLIGHT BURNING SMELL WHEN FIRST USED. THIS PHENOMENON SHOULD BE CONSIDERED NORMAL AND WILL DISAPPEAR AS SOON AS THE CLUTCH PLATES GET ADAPTED.

IT IS IMPORTANT TO STRAIN ENGINE COMPONENTS DURING RUN-IN, HOWEVER, MAKE SURE NOT TO OVERDO THIS.

CAUTION

THE FULL PERFORMANCE OF THE VEHICLE IS ONLY AVAILABLE AFTER THE SERVICE AT THE END OF THE RUNNING IN PERIOD.

Follow the guidelines detailed below:

- Do not fully open the throttle grip abruptly at low engine speeds, either during or after the running in period.
- During the first 100 Km (62 miles) use the brakes gently, avoiding sudden or prolonged braking. That is to permit the adequate adjustment of the pad friction material to the brake discs.



AFTER THE SPECIFIED MILEAGE, TAKE THE VEHICLE TO AN OFFICIAL Moto Guzzi DEALER FOR THE CHECKS INDICATED IN THE "AFTER RUN-IN" TABLE IN THE SCHEDULED MAINTENANCE SECTION TO AVOID INJURING YOURSELF, OTHERS AND /OR DAMAGING THE VEHICLE.

- Between 1000 km (625 miles) and 2000 km (1250 miles) travelled, ride more vigorously, vary speeds and twist throttle fully for some short periods for best coupling of the components; do not exceed 6000 rpm.
- After 2000 km (1250 miles) a better engine performance may be expected, but without exceeding the engine maximum rpm allowed (7600 rpm).

Vehicle identification

SERIAL NUMBER LOCATION

These numbers are necessary for vehicle registration.

NOTE

ALTERING IDENTIFICATION NUMBERS MAY BE SERIOUSLY PUNISHABLE BY LAW. IN PARTICULAR, MODIFYING THE FRAME NUMBER IMMEDIATELY VOIDS THE WARRANTY.

This number is composed by numbers and letters, as in the example shown below.

ZGULP000YMXXXXXX

KEY:

ZGU: WMI (World manufacture identifier) code;

LP: model;

000: version variation;

0: digit free

Y: year of manufacture

M: production plant (M= Mandello del Lario);

XXXXXX: progressive number (6 digits);

CHASSIS NUMBER

The chassis number is stamped on the right side of the headstock.

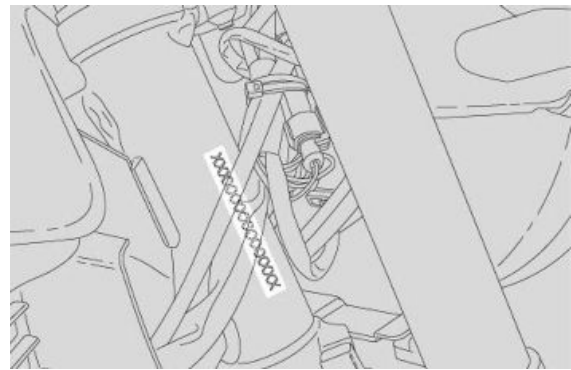

ENGINE NUMBER

The engine number is stamped on the left side, close to the engine oil level check cap.



Dimensions and mass

WEIGHT AND DIMENSIONS

Specification	Desc./Quantity
Length	2195 mm (86.4 in)
Width	870 mm (34.2 in)
Maximum height	1125 mm (44.3 in)
Saddle height	800 mm (31.5 in)
Minimum earth clearance	185 mm (7.3 in)
Wheelbase	1495 mm (58.8 in)
Kerb weight	248 kg (547 pounds)

Engine

ENGINE

Specification	Desc./Quantity
Type	traverse-mounted twin-cylinder four-stroke V 90°
No. of cylinders	2
Cylinder arrangement	V 90°
Total engine capacity	1064 cm3 (65 cu in)
Bore / stroke	92 x 80 mm (3.6 x 3.1 in)

Specification	Desc./Quantity
Compression ratio	9.8 :1
Electric	starter
Engine idle speed	1100 ± 100 rpm
Clutch	dry, twin disc with hydraulic control
Lubrication	Pressure-fed, controlled by valves and trochoidal pump
Air filter	cartridge-type dry filter
Cooling	air
Fuel system	Electronic injection (Weber . Marelli) with stepper motor
Diffuser	Ø 45 mm (1.77 in)
Fuel	Premium unleaded petrol, minimum octane rating 95 (NORM) and 85 (NOMM)
Timing system diagram:	2 rod valves and rocking levers
Valid values with checking clearance between rocking levers and valve	inlet: 0.10 mm (0.0039 in) outlet: 0.15 mm (0.0059 in)

Transmission

TRANSMISSION

Specification	Desc./Quantity
Main transmission	with gear, ratio: 26/35 = 1 :1.3461
Gearbox	Mechanical, 6 speeds with foot lever on the left hand side of the engine
Gear ratios:	1st gear : 17/38 = 1 :2.2353 2nd gear : 20/34 = 1:1.7 3rd gear : 23/31 = 1:1.3478 4th gear : 26/29 = 1:1.1154 5th gear : 31/30 = 1:0.9677 6th gear : 29/25 = 1:0.8621
Final drive	with U-joint
Ratio	12/44 = 1:3.6667

Capacities

CAPACITY

Specification	Desc./Quantity
Engine oil	Oil and oil filter change 3600 cm ³ (219 cu.in)
Gearbox oil	500 cm ³ (30.5 cu.in)
Transmission oil	380 cm ³ (23.2 cu.in)
Fuel (reserve included)	23 l (6.1 gal)
Fuel reserve	4 l (1.06 gal)
Fork oil	400 ± 2.5 cm ³ (24.4 ± 0.15 in) (for each stem)
Seats	2
Vehicle maximum load	230 Kg (507 pounds) (rider + passenger + luggage)

Electrical system

ELECTRICAL SYSTEM

Specification	Desc./Quantity
Outer spark plug	NGK BPR6ES
Inner spark plug (long life) (only for 1100 - 1200 models)	NGK PMR8B
Electrode gap	0.6 - 0.7 mm (0.024 - 0.028 in)
Battery	12 V - 18 Ampere/hour
Alternator (permanent magnet type)	12 V - 550 W
Main fuses	30 A
ABS fuses	40 - 25A
Secondary fuses	3 - 15 - 20 A (only 10A for ABS)
Daylight running light	12V - 5 W
Low-beam light	12 V - 55 W H7

Specification	Desc./Quantity
High-beam light	12 V - 65 W H9
Turn indicators	12V - 10 W (orange bulb)
Rear daylight running light/stop light	LED
Dashboard lighting	LED
License plate light	12V - 5 W
Turn indicator warning light	LED
ABS warning light	LED
Neutral gear warning light	LED
Alarm warning light	LED
Side stand down warning light	LED
Low fuel warning light	LED
High beam warning light	LED
Antitheft device warning light	LED
Gear shift warning light	LED

Frame and suspensions

CHASSIS

Specification	Desc./Quantity
Type	high strength steel tube chassis
Trail	120 mm (4.72 in)
Headstock angle	25° 30'
Front	hydraulic telescopic fork; Ø 45 mm (1.77 in)
Wheel travel	120 mm (4.72 in)
Rear	single arm suspension with progressive linkage, single shock absorber with adjustable rebound and ergonomic knob for spring preloading adjustment.
Wheel travel	140 mm (5.5 in)

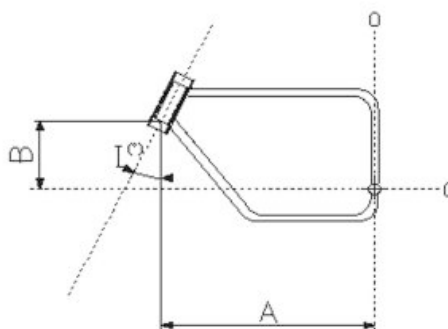

SIZES A AND B

Specification	Desc./Quantity
Size A	758.9 +/- 1 mm (29.88 +/- 0.04 in)
Size B	345.5 mm (13.60 in)

Brakes

BRAKES

Specification	Desc./Quantity
Front	twin Ø 320 mm (12.6 in) stainless steel floating disc, calliper with 4 different and counteracting plungers
Rear	282 mm (11.1 in) diam. stainless steel disc

Wheels and tyres

WHEELS AND TYRES

Specification	Desc./Quantity
Type	hollow 3-spoke rim in chilled cast aluminium alloy
Front wheel rim	3.50" x 17"
Rear wheel rim	5.50" x 17"
Tyres	METZELER Roadtec Z6 MICHELIN Pilot Road DUNLOP D220 ST Sportmax
Front	120/70 - ZR 17" 58 W
Inflation pressure (front)	2.5 bar (250 kPa) (36.3 PSI)
Inflation pressure with passenger (front)	2.5 bar (250 kPa) (36.3 PSI)
Rear	180/55 - ZR 17" 73 W
Inflation pressure (rear)	2.8 bar (280 kPa) (40.6 PSI)
Inflation pressure with passenger (rear)	2.8 bar (280 kPa) (40.6 PSI)

Tightening Torques

HEADS

Name	Torque in Nm
Oil cap (2)	25 Nm (18.44 lbf ft)
Exhaust system stud bolt (4)	10 Nm (7.38 lbf ft) - Loctite 648
Rocking lever support nut - M10x1.5 (8)	15 Nm (11.06 lbf ft) + 90° + 90°
Rocking lever nut (4)	10 Nm (7.38 lbf ft)
Set screw - TE M6x16 (4)	10 Nm (7.38 lbf ft)
Head cover screw - M6x25 (16)	10 Nm (7.38 lbf ft)
Head fixing screw (4)	15 Nm (11.06 lbf ft) + 90°
Oil temperature sensor	11 Nm (8.11 lbf ft) - Loctite 243
Oil temperature sensor container	11 Nm (8.11 lbf ft) - Loctite 601
Outer Spark plugs	30 Nm (22.13 lbf ft) - Molikote
Inner spark plugs	15 Nm (11.06 lbf ft) - Molikote

CRANKCASE

Name	Torque in Nm
Crankcase stud bolt - cylinder (8)	25 Nm (18.44 lbf ft)
Transmission side flange stud bolt - M8x66 (3)	35 Nm (25.81 lbf ft)
Transmission side flange stud bolt - M8x75 (2)	35 Nm (25.81 lbf ft)
Crankshaft flange screw - TE M8x25 (14)	25 Nm (18.44 lbf ft)
Timing system cover screw - TCEI M8x55 (4)	25 Nm (18.44 lbf ft)
Timing system cover screw - TCEI M6x30 (10)	10 Nm (7.38 lbf ft)
Oil vapour union screw - TCEI M6x20 (2)	10 Nm (7.38 lbf ft)
Timing system outer cover screw - TCEI M6x16 (4)	10 Nm (7.38 lbf ft)
Screw TSPEI M4x8 (2)	5 Nm (3.69 lbf ft) - Loctite 243
TCEI M6x40 Screw (2)	10 Nm (7.38 lbf ft)
Timing sensor - TCEI M5x12 (2)	6 Nm (4.42 lbf ft)
Crankcase stud bolts - chassis (4)	40 Nm (29.5 lbf ft) - Loctite 601

OIL SUMP

Name	Torque in Nm
Oil radiator pipe fitting on sump (2)	20 Nm (14.75 lbf ft)
Oil pipe on sump	20 Nm (14.75 lbf ft)
Oil sump lower screw - TCEI M6x30 (4)	10 Nm (7.38 lbf ft)
Oil sump screw - TCEI M6x55 (14)	10 Nm (7.38 lbf ft)
Oil sump screw - TCEI M6x60 (2)	10 Nm (7.38 lbf ft)
Oil drainage plug - M10x1 (1)	20 Nm (14.75 lbf ft)
Oil filter (1)	15 Nm (11.06 lbf ft)
Oil filter fitting (1)	40 Nm (29.5 lbf ft) - Loctite 243
Oil pipe in sump	20 Nm (14.75 lbf ft) - Loctite 648
Thermostat cap	40 Nm (29.5 lbf ft)
Pressure-relief plug	40 Nm (29.5 lbf ft)

Name	Torque in Nm
Oil intake filter fixing screw - TCEI M6x16 (1)	10 Nm (7.38 lbf ft) - Loctite 648

OIL PUMP

Name	Torque in Nm
Oil pump fixing screw - TBEI M6x30 (3)	10 Nm (7.38 lbf ft) - Loctite 243
Oil pump gear nut - M10x1.25 (1)	20 Nm (14.75 lbf ft)
Oil delivery pipe screw (1)	17 Nm (12.54 lbf ft)
Oil pressure sensor	45 Nm (33.19 lbf ft)

TIMING SYSTEM

Name	Torque in Nm
Camshaft flange screw - TE M6x20 (3)	10 Nm (7.38 lbf ft)
Timing system gear nut on camshaft - M18 (1)	150 Nm (110.63 lbf ft)
Timing system gear nut on crankshaft - M25 (1)	120 Nm (88.51 lbf ft)
Camshaft support screw on timing system cover - TCEI M4x10 (4)	5 Nm (3.69 lbf ft) - Loctite 243
Belt tension	50 Nm (36.88 lb ft)

GENERATOR

Name	Torque in Nm
Alternator fixing screw - TCEI M8x45 (1)	22 Nm (16.23 lbf ft)
Alternator fixing nut - M10x1.5 (1)	30 Nm (22.13 lbf ft)
Alternator pulley nut on crankshaft - M16 (1)	80 Nm (59 lbf ft) - Loctite 243

CRANKSHAFT - FLYWHEEL

Name	Torque in Nm
Start-up crown fixing screw on flywheel (8)	18 Nm (13.28 lbf ft) - Loctite 243
Connecting rod screw (4) - pre-tightening	40 Nm (29.5 lbf ft)
Connecting rod screw (4) - final tightening	80 Nm (59 lbf ft)
Flywheel fixing screw on crankshaft - M8x25 (6)	42 Nm (30.98 lbf ft) - Loctite 243

GEAR

Name	Torque in Nm
Gear shift cable lever nut	10 Nm (7.38 lbf ft)
Gear shift tie rod lever nut on gear pre-selector	10 Nm (7.38 lbf ft)
Gearbox to crankcase fixing nut - M8 (5)	20 Nm (14.75 lbf ft)
TE flanged screw fixing gearbox to crankcase - M8x45 (1)	20 Nm (14.75 lbf ft)
Oil cap M18x1.5 (1)	28 Nm (20.65 lbf ft)
Breather cap (1)	8 Nm (5.9 lbf ft)
Gear in neutral sensor (1)	10 Nm (7.38 lbf ft)
Oil drainage plug - M10x1 (1)	24 Nm (17.7 lbf ft)
Transmission shaft ring nut (1)	100 Nm (73.76 lbf ft)

CHASSIS TO ENGINE UNIT

Name	Torque in Nm
M6x40 TCEI DA screw	8 -12 Nm
Reduction	20 Nm

FUEL SUPPLY CONTROL UNIT

Name	Torque in Nm
M5x12 TCEI screw	6 -7 Nm
Stainless M5x16 TBEI flanged screw	6 -7 Nm
M6x25 TCEI DA screw	8 -12 Nm

CHASSIS

Name	Torque in Nm
Electronic control unit retainer + coil plates	10 Nm
Electronic control unit retainer	10 Nm
Tank support rubber rings to chassis retainer	25 Nm
Gearbox to chassis retainer	80 Nm

Name	Torque in Nm
Coil retainer	2 Nm
Engine retainer	80 Nm
Left and right footrest plate to chassis upper retainer	20 Nm
Right footrest plate to chassis lower retainer	30 Nm
Left footrest plate to chassis lower retainer	30 Nm
Right/left protection cover retainer	6 Nm
Plate ring to plate retainer	6 Nm
Handgrip to chassis fixing screw	25 Nm
Cover to handgrip retainer	25 Nm

FOOTRESTS AND LEVERS

Name	Torque in Nm
Footrest rubber retainer	10 Nm
Rod retainer (nut)	10 Nm
Gear shift lever / brake pin retainer	10 Nm
Gear shift lever / pre-selector retainer	10 Nm
Spring hook pin	4 Nm

SIDE STAND

Name	Torque in Nm
Stand plate to engine retainer	80 Nm
Side stand retainer pin	10 Nm
Switch fixing screw	10 Nm
Lock nut	30 Nm

CENTRE STAND

Name	Torque in Nm
Stand to plates fixing screw	50 Nm
Pipe guide ring to plates fixing screw	10 Nm

FRONT SUSPENSION

Name	Torque in Nm
Speed sensor retainer	10 Nm
Tube lock plate to steering base retainer	6 Nm
Fork stem to lower / upper plate retainer	25 Nm
Headstock ring nut	40 Nm
Headstock counter ring nut	manual + 90 degrees
Upper yoke fixing cap	100 Nm
Fork hubs closing	10 Nm

REAR SUSPENSION

Name	Torque in Nm
Shock absorber to chassis retainer - 8.8	50 Nm
Double connecting rod/shock absorber retainer - 10.9	40 Nm
Single connecting rod/double connecting rod retainer - 10.9	50 Nm
Single connecting rod to chassis retainer - 8.8	50 Nm
Double connecting rod/swingarm retainer - 10.9	50 Nm

AIR FILTER CASING

Name	Torque in Nm
Filter casing cover/filter casing bracket	3 Nm
Blow-by tank to filter casing cover retainer	3 Nm
Air temperature sensor retainer	2 Nm

EXHAUST

Name	Torque in Nm
Exhaust pipe to engine retainer	25 Nm
Exhaust pipe to compensator retainer (clamp)	10 Nm
Compensator to plate retainer	25 Nm
Compensator to silencer retainer (clamp)	10 Nm
Lambda probe retainer	38 Nm

Name	Torque in Nm
Silencer to support retainer (screw +nut)	25 Nm

FRONT WHEEL

Name	Torque in Nm
Wheel pin nut	80 Nm
Disc retainer	30 Nm

REAR WHEEL

Name	Torque in Nm
Disc retainer	30 Nm
Rear wheel retainer 10.9	110 Nm

FRONT BRAKING SYSTEM

Name	Torque in Nm
Front brake right and left calliper retainer	40 Nm

REAR BRAKING SYSTEM

Name	Torque in Nm
Rear brake calliper retainer	50 Nm
Rear brake lever pin	15 Nm
Rear brake fluid reservoir retainer	3 Nm
Rear brake fluid reservoir support to plate retainer	10 Nm
Rear brake rod lock nut	manual
Brake lever spring to plate retainer	6 Nm
Brake pump retainer	10 Nm

HANDLEBAR AND CONTROLS

Name	Torque in Nm
Half-handlebar to steering plate retainer	25 Nm
Handlebar pipes to half-handlebar retainer	25 Nm
Anti-vibration counterweight fastener	10 Nm

ELECTRICAL SYSTEM

Name	Torque in Nm
Horn retainer	15 Nm
Speed sensor to front fork retainer	12 Nm

INSTRUMENT PANEL AND LIGHTS

Name	Torque in Nm
Instrument panel support to light support retainer	10 Nm
Instrument panel support to fork upper plate retainer	25 Nm
Instrument panel retainer	3 Nm
Light support to fork lower plate retainer	25 Nm
Light + turn indicators retainer	10 Nm
Rear light to handgrip retainer	4 Nm

FUEL PUMP FLANGE

Name	Torque in Nm
Tank breather joint	6 Nm
Pump support to tank retainer	4 Nm

FUEL TANK

Name	Torque in Nm
Filler to tank retainer	4 Nm
Rear screw fixing the tank to the chassis - M8x45	25 Nm

CHASSIS / FAIRINGS (FRONT)

Name	Torque in Nm
Air inlet to tank retainer	4 Nm

Name	Torque in Nm
Lug to engine retainer	25 Nm
Right to left lug retainer	4 Nm
Front mudguard retainer	4 Nm

CHASSIS/ FAIRINGS (REAR)

Name	Torque in Nm
Tail section + fairing retainer	4 Nm
Tail section to handgrip retainer	4 Nm
Net hooks to chassis retainer	25 Nm
Retroreflector to support retainer	4 Nm
Retroreflector support to license plate holder retainer	4 Nm
License plate lamp to license plate holder retainer	4 Nm

FINISHINGS

Name	Torque in Nm
Ignition lock retainer - shear head screw	- Nm
Ignition lock retainer	25 Nm

SWINGARM

Name	Torque in Nm
Swingarm on bushing clamp retainer	10 Nm
Swingarm on bevel gear pair retainer	50 Nm
Reaction rod to bevel gear pair retainer	50 Nm
Reaction rod to chassis retainer	50 Nm
Swingarm bolt to swingarm retainer	60 Nm
Preloading bushing to swingarm bolt retainer	10 Nm

Overhaul data

Assembly clearances

Cylinder - piston assy.

Measurement of the cylinder diameter must be done at three heights, turning the dial gauge 90°.

Check the clearance between the cylinders and pistons; if it exceeds the value specified, it is necessary to replace cylinders and pistons.

The pistons of an engine must be balanced; a weight difference of up to 1.5 (0.0033 lb) is admitted.

ADMITTED MEASUREMENTS

Specification	Desc./Quantity
cylinder diameter	92.000 - 92.020 mm (3.62204 - 3.62282 in)
piston diameter	91.947 - 91.967 mm (3.61995 - 3.62074 in)
fitting clearance	0.048 - 0.068 mm (0.00189 - 0.00268 in)

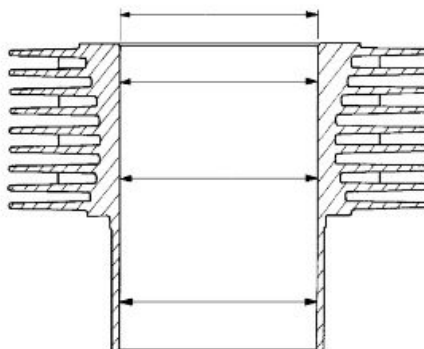

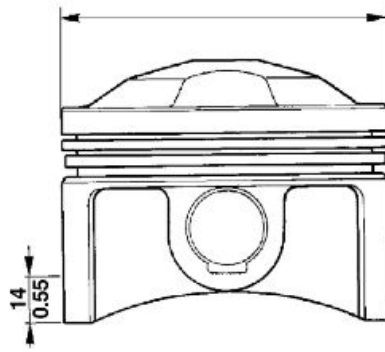

Piston rings

Check the sealing piston rings and the oil scraper.

On each piston there are:

- 1 top piston ring;
- 1 middle stepped piston ring;
- 1 oil scraper piston ring.

The ends of the fitted piston rings are out of phase.

Fitting backlash detected between the ring thickness and seats on the piston:

Sealing rings and oil scraper 0.030 - 0.065 mm (0.00118 - 0.00256 in)

Gap between the end of the piston rings inserted in the cylinder:

Upper sealing ring and stepped ring 0.40 - 0.65 mm (0.00158 - 0.00255 in)

Oil scraper ring 0.30 - 0.60 mm (0.00118 - 0.00236 in).

Turn the rings so that the coupling ends are 120 degrees from each other.

Crankcase - crankshaft - connecting rod

CAMSHAFT (CAM) SUPPORT DIAMETER AND THEIR SEATS ON THE CRANKCASE (TIMING SYSTEM SIDE)

Specification	Desc./Quantity
Shaft support diameter	47.000 - 46.984 mm (1.85039 ÷ 1.84976 inch)
Seat diameter on base	47.025 - 47.050 mm (1.85137 ÷ 1.85236 inch)
fitting clearance	0.025 - 0.066 mm (0.00098 ÷ 0.00260 inch)

CAMSHAFT (CAM) SUPPORT DIAMETER AND THEIR SEATS ON THE CRANKCASE (FLYWHEEL SIDE)

Specification	Desc./Quantity
Shaft support diameter	32.000 - 31.984 mm (1.25984 ÷ 1.25921 inch)
Seat diameter on base	32.025 - 32.050 mm (1.26082 ÷ 1.26181 inch)
fitting clearance	0.025 - 0.066 mm (0.00098 ÷ 0.00260 inch)

TAPPET-SEAT COUPLING ON CRANKCASE DATA (PRODUCTION)

Specification	Desc./Quantity
Seats diameter	22.021 - 22.000 mm (0.86697 ÷ 0.86614 inch)
Tappet external diameter	21.996 - 21.978 mm (0.86598 ÷ 0.86527 inch)
Fitting clearances	0.004 - 0.043 mm (0.00016 ÷ 0.00169 in.)

Recommended products chart**RECOMMENDED PRODUCTS**

Product	Description	Specifications
AGIP RACING 4T 10W-60	Engine oil	SAE 10W - 60. As an alternative to recommended fluids, use top branded oils with performances that meet or exceed the requirements of CCMC G-4 API. SG specifications.
AGIP GEAR SAE 80 W 90	Transmission oil	-
AGIP GEAR MG/S SAE 85 W 90	Gearbox oil	-
AGIP FORK 7.5W	Fork oil	SAE 5W / SAE 20W
AGIP GREASE SM2	Lithium grease with molybdenum for bearings and other points needing lubrication	NLGI 2
Neutral grease or petroleum jelly.	Battery poles	
AGIP BRAKE 4 / BRAKE 5.1	Brake fluid	As an alternative for recommended fluids, use top branded fluids that meet or exceed the requirements of SAE J1703, NHTSA 116 DOT 4, ISO 4925 synthetic fluid specifications.
AGIP BRAKE 4 / BRAKE 5.1	Clutch fluid	As an alternative for recommended fluids, use top branded fluids that meet or exceed the requirements of SAE J1703, NHTSA 116 DOT 4, ISO 4925 synthetic fluid specifications.

NOTE





USE ONLY NEW BRAKE FLUID. DO NOT MIX DIFFERENT BRANDS OR TYPES OF OIL WITHOUT CHECKING THEIR BASE COMPATIBILITY.

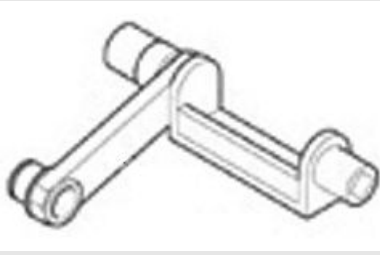
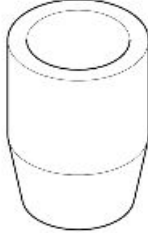
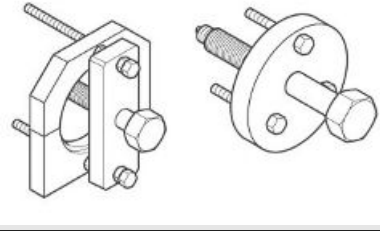

INDEX OF TOPICS

SSPECIAL TOOLS

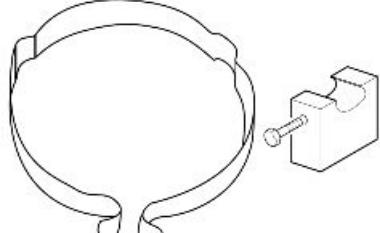
S-TOOLS

SPECIAL TOOLS

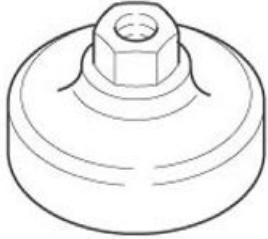
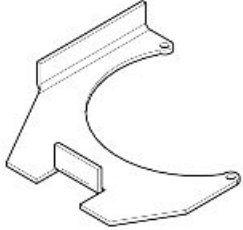
Stores code	Description	
05.94.86.30	Belt tension tool	
05.91.17.30	Front cover insertion cone	
05.91.25.30	Gearbox opening	
05.90.19.30	Inner spark plug removal	
05.92.80.30	Piston ring clamp	
05.92.72.30	Timing system cover sealing ring punch	

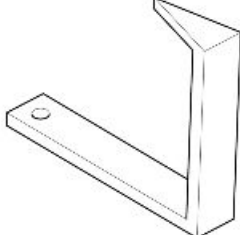
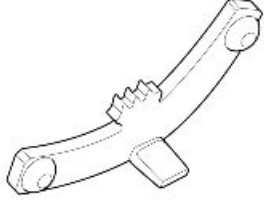
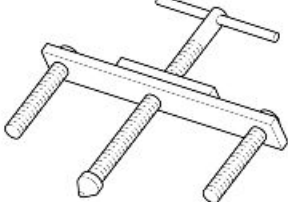
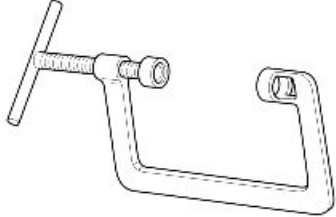
Stores code	Description	
01.92.91.00	Wrench for removing the cover on sump and filter	
05.90.25.30	Gearbox support	
19.92.96.00	Graduated dial to control ignition timing	
17.94.75.60	Arrow to control ignition timing	
12.91.18.01	Tool to lock the flywheel and the starting ring gear	
12.91.36.00	Tool to remove the flywheel-side flange	
10.90.72.00	Tool for valve removal and refitting	

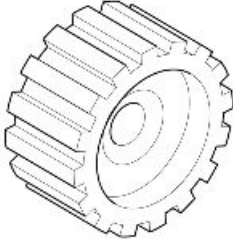
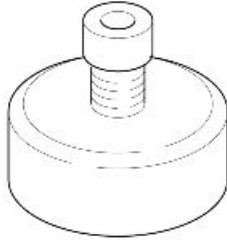
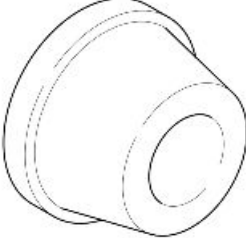
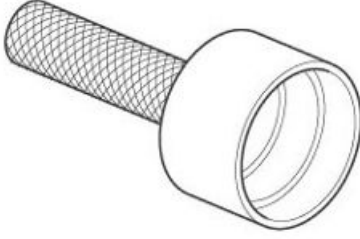
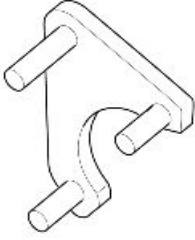
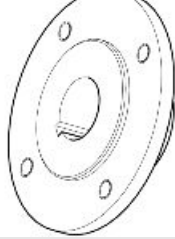
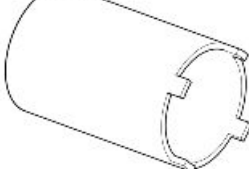
Stores code	Description	
30.90.65.10	Tool for clutch fitting	
14.92.71.00	Tool to fit the sealing ring on the flywheel-side flange	
12.91.20.00	Tool to fit the flywheel-side flange together with seal ring on the crankshaft	
19.92.71.00	Tool to fit the seal ring on the flywheel-side flange	
14.92.73.00	Tool for camshaft gear sealing	
981006	Graduated dial hub	
AP8140190	Tool for steering tightening	

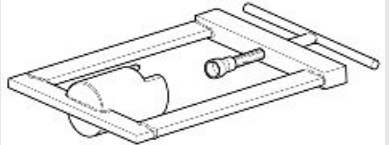
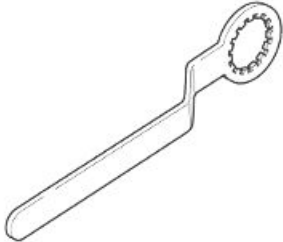
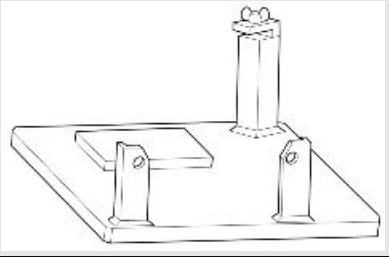
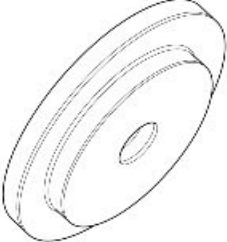
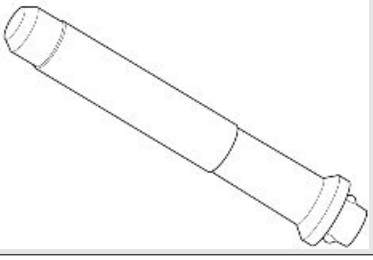
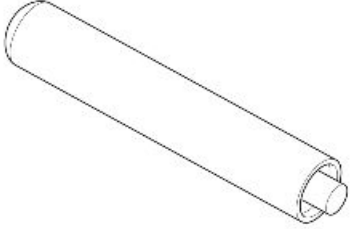
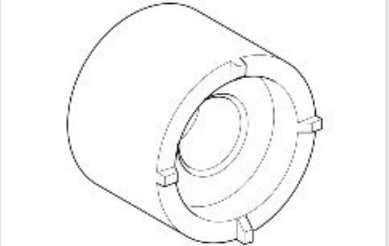
Stores code	Description	
000019663300	Tool for clutch shaft removal	
30.91.28.10	Clutch body locking	
05.90.27.30	Gearbox support	
05.90.27.31	Gearbox oil seal buffer	
05.90.27.32	Buffer handgrip	
05.90.27.33	Ball joint sealing buffer	
05.90.27.34	Wrench for pinion ring nut	

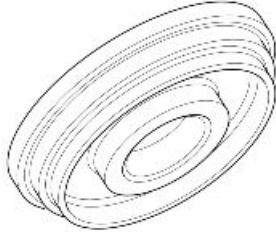
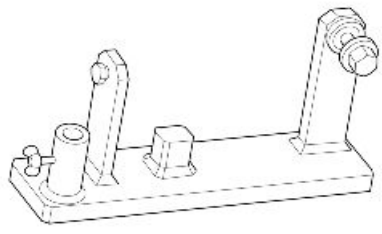
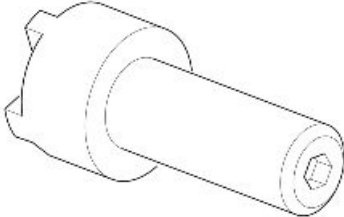
Stores code	Description	
05.90.27.35	Pinion oil seal buffer	
05.90.27.36	Bevel gear pair support	
GU14912603	Hook spanner for fixing ring nut of the clutch shaft internal body	

INDEX OF TOPICS

MAINTENANCE

MAIN

Maintenance chart

NOTE

CARRY OUT MAINTENANCE OPERATIONS AT HALF THE INTERVALS SPECIFIED IF THE VEHICLE IS USED IN PARTICULAR RAINY OR DUSTY CONDITIONS, OFF ROAD OR FOR TRACK USE.

AT EVERY START-UP

Action

Engine oil pressure warning light - check and clean, adjust, grease or replace if necessary

BEFORE EACH RIDE AND EVERY 2000 KM (1250 MI)

Action

Tyre pressure - Adjust

Brake pad wear - Check and clean, adjust or replace if necessary

AFTER RUN-IN (1,500 KM (932 MI)

Action

Exhaust pipe flange bolts - Check and clean, adjust, grease or replace if necessary

Transmission cables and controls - Check and clean, adjust, grease or replace if necessary

Steering bearings and steering clearance - Check and clean, adjust, grease or replace if necessary.

Disc brakes - Check and clean, adjust or replace if necessary

Engine oil filter - Replace

Fork - Check and clean, adjust and lubricate

General vehicle operation - Check and clean, adjust, grease or replace if necessary.

Braking systems - Check and clean, adjust, grease or replace if necessary

Light circuit - Check and clean, adjust or replace if necessary

Safety switches - Check and clean, adjust, grease or replace if necessary

Gearbox oil - Change

Engine oil - Change

Final transmission oil - Change

Tyres - Check and clean, adjust, grease or replace if necessary

Tyre pressure - Adjust

Engine revs at idle speed - Adjustment.

Valve clearance adjustment - Adjust

Wheels - Check and clean, adjust, grease or replace if necessary

Bolts, nuts and screws tightening - Check and clean, adjust, grease or replace if necessary

Battery terminals tightening - Check and clean, adjust, grease or replace if necessary

Cylinder synchronisation - Check and clean, adjust, grease or replace if necessary

Suspensions and setting - Check and clean, adjust, grease or replace if necessary

Brake pad wear - Check and clean, adjust or replace if necessary

EVERY 4 YEARS

Action

Fuel pipes - Replace

Brake pipes - Replacement

EVERY 5000 KM (3125 MI) - IF THE VEHICLE IS USED FOR RACING

Action

Outer spark plugs - Replace

Engine oil filter - Replace

Engine oil - Change

Purge fluid present in oil drainage pipe from the filter housing - Clean

Clutch wear - Check and clean, adjust, grease or replace if necessary

EVERY 10,000 KM (6250 MILES) OR 12 MONTHS

Action

Outer spark plugs - Replace

Idle mixture (CO) - Check and clean, adjust, grease or replace if necessary

Transmission cables and controls - Check and clean, adjust, grease or replace if necessary

Action

Steering bearings and steering clearance - Check and clean, adjust, grease or replace if necessary.
Wheel bearings - Check and clean, adjust, grease or replace if necessary
Disc brakes - Check and clean, adjust or replace if necessary
Air filter - Check and clean, adjust, grease or replace if necessary
Engine oil filter - Replace
General vehicle operation - Check and clean, adjust, grease or replace if necessary.
Braking systems - Check and clean, adjust, grease or replace if necessary
Gearbox oil - Change
Engine oil - Change
Final transmission oil - Change
Valve clearance adjustment - Adjust
Wheels - Check and clean, adjust, grease or replace if necessary
Bolts, nuts and screws tightening - Check and clean, adjust, grease or replace if necessary
Cylinder synchronisation - Check and clean, adjust, grease or replace if necessary
Purge fluid present in oil drainage pipe from the filter housing - Clean
Fuel pipes - Check and clean, adjust, grease or replace if necessary
Brake pipes - Check and clean, adjust, grease or replace if necessary
Clutch wear - Check and clean, adjust, grease or replace if necessary

AFTER THE FIRST 10,000 KM (6,250 MILES) AND THEN AFTER EVERY 20,000 KM (12,500 MILES)**Action**

Fork oil - Change
Fork oil seals - Replace

EVERY 20000 KM (12500 MILES) OR 24 MONTHS**Action**

Inner spark plugs - Replace
Alternator belt - Adjust; EVERY 50,000 km (31,050 mi)
Air filter - Replace
Fork - Check and clean, adjust and lubricate
Brake fluid - change
Suspensions and setting - Check and clean, adjust, grease or replace if necessary
Brake pad wear - Check and clean, adjust or replace if necessary

Transmission fluid**Check**

- Keep the vehicle upright with both wheels on the ground.
- Unscrew and remove the cap/dipstick (1).
- The level is correct if the oil is close to the hole of the cap/dipstick (1).
- If the oil is lower than specified, top-up until it reaches the cap/dipstick hole (1).

CAUTION

DO NOT ADD ADDITIVES OR ANY OTHER SUBSTANCE TO THE FLUID. WHEN USING A FUNNEL OR ANY OTHER ELEMENT, MAKE SURE IT IS PERFECTLY CLEAN.

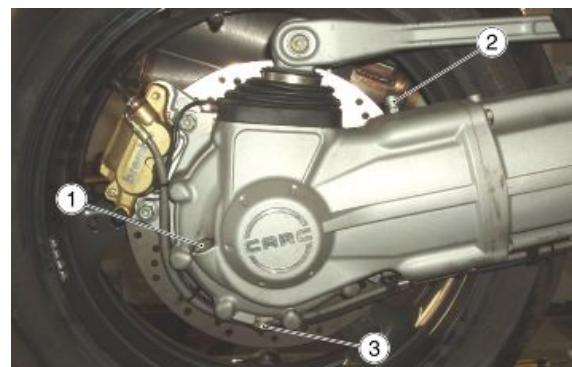

Replacement

CAUTION

THE UNIT MUST BE HOT WHEN THE OIL IS CHANGED AS UNDER SUCH CONDITIONS OIL IS FLUID AND THEREFORE EASY TO DRAIN.

NOTE

RIDE SOME km (miles) TO WARM UP ENGINE OIL

- Place a container with + 400 cm³ (25 cu in) capacity under the drainage plug (3).
- Unscrew and remove the drainage plug (3).
- Unscrew and remove the breather cap (2).
- Drain the oil into the container; allow several minutes for oil to drain out completely.
- Check and if necessary, replace the sealing washer of drainage plug (3).
- Remove any metal scrap attached to the drainage plug (3) magnet.
- Screw and tighten the drainage plug (3).
- Pour new oil through the fill opening (1) until it reaches the cap/dipstick hole (1).

CAUTION

DO NOT ADD ADDITIVES OR ANY OTHER SUBSTANCE TO THE FLUID. WHEN USING A FUNNEL OR ANY OTHER ELEMENT, MAKE SURE IT IS PERFECTLY CLEAN.

- Screw and tighten the caps (1 - 2).

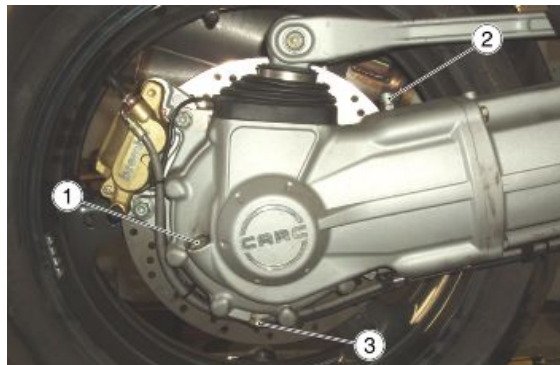

Engine oil

Check

CAUTION

ENGINE MUST BE WARM TO CHECK ENGINE OIL LEVEL.

NOTE

DO NOT LET THE ENGINE IDLE WITH THE VEHICLE AT STANDSTILL TO WARM UP THE ENGINE OIL AND REACH THE OPERATING TEMPERATURE OF ENGINE OIL. OIL IS BEST CHECKED AFTER RUNNING FOR ABOUT 15 KM (10 miles).

- Shut off the engine.
- Keep the vehicle upright with the two wheels on the ground.
- Unscrew and remove the dipstick (1).
- Clean the dipstick (1).
- Reinsert the dipstick (1) into the opening but do not screw it.

- Remove the dipstick (1).
- Check oil level on the dipstick (1).
- The oil level is correct when it close to the "MAX" mark.

MAX = maximum level

MIN = minimum level

Add engine oil if required:

- Unscrew and remove the dipstick (1).
- Top-up with engine oil until it goes above the minimum level marked "MIN".

CAUTION

DO NOT ADD ADDITIVES OR ANY OTHER SUBSTANCE TO THE FLUID. WHEN USING A FUNNEL OR ANY OTHER ELEMENT, MAKE SURE IT IS PERFECTLY CLEAN.

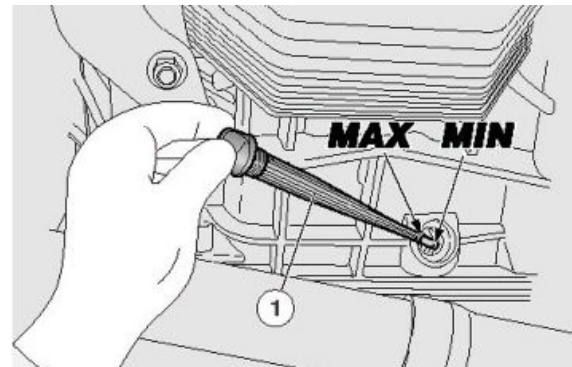

Replacement

NOTE

HOT OIL IS MORE FLUID AND WILL DRAIN OUT MORE EASILY AND COMPLETELY.

- Place a container with + 4000 cm³ (245 cu in) capacity under the drainage plug (2).
- Unscrew and remove the drainage plug (2).

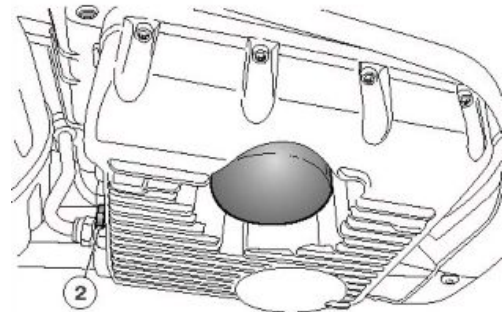

- Unscrew and remove the filler plug (3).
- Drain the oil into the container; allow several minutes for oil to drain out completely.
- Check and if necessary, replace the sealing washers of drainage plug (2).
- Remove any metal scrap attached to the drainage plug (2) magnet.

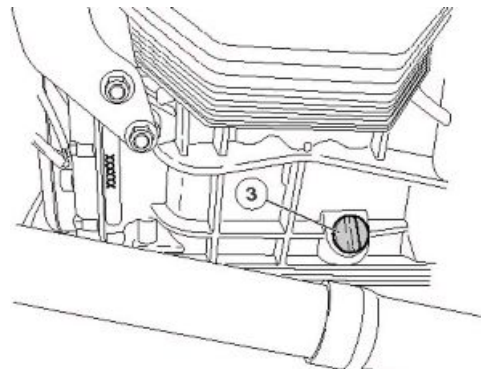

- Screw and tighten the drainage plug (2).
- Pour new oil until it goes above the minimum level marked "MIN".

Engine oil filter

- Unscrew and remove the engine oil filter from its seat.

NOTE

NEVER REUSE AN OLD FILTER.

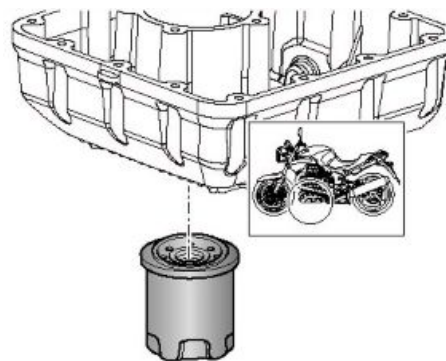

- Spread a thin layer of oil on the sealing ring of the new engine oil filter.
- Fit and screw the new oil filter in its seat.

Gearbox Oil

Inspection

CHECKING AND TOPPING UP

CAUTION

ENGINE MUST BE WARM TO CHECK GEARBOX OIL LEVEL.

NOTE

DO NOT LET THE ENGINE IDLE WITH THE VEHICLE AT STANDSTILL TO WARM UP THE ENGINE OIL AND REACH THE OPERATING TEMPERATURE OF ENGINE OIL. OIL IS BEST CHECKED AFTER RUNNING FOR ABOUT 15 KM (10 miles).

- Shut off the engine.
- Keep the vehicle upright with both wheels on the ground.
- Undo and remove the dipstick opening (1) located on the right side of the gearbox.
- The level is correct if the oil is close to the hole of the dipstick (1).

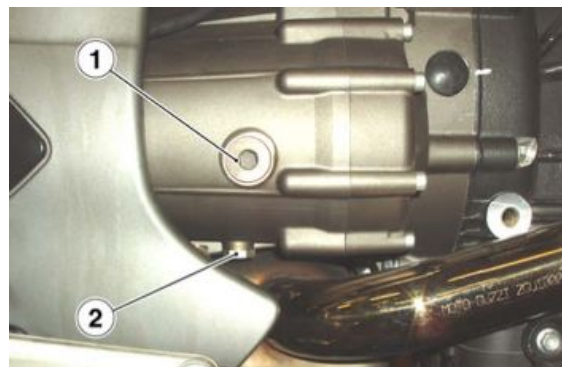

If necessary:

- Top-up with oil until it reaches the dipstick opening (1).

CAUTION

DO NOT ADD ADDITIVES OR ANY OTHER SUBSTANCE TO THE FLUID. WHEN USING A FUNNEL OR ANY OTHER ELEMENT, MAKE SURE IT IS PERFECTLY CLEAN.

Replacement

NOTE

HOT OIL IS MORE FLUID AND WILL DRAIN OUT MORE EASILY AND COMPLETELY.

- Place a container with suitable capacity under the drainage plug (2).
- Unscrew and remove the drainage plug (2).
- Unscrew and remove the filler cap (1).
- Drain the oil into the container; allow several minutes for oil to drain out completely.
- Check and replace, if necessary, the sealing washers of drainage plug (2).
- Remove any metal scrap attached to the drainage plug (2) magnet.
- Screw and tighten the drainage plug (2).
- Pour in new oil until it reaches the dipstick opening (1).
- Tighten the filler cap (1).

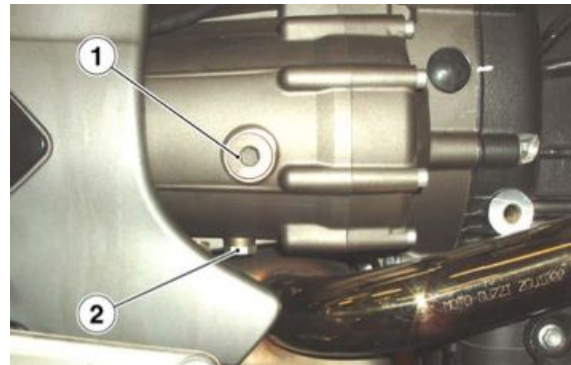
**CAUTION**

DO NOT ADD ADDITIVES OR ANY OTHER SUBSTANCE TO THE FLUID. WHEN USING A FUNNEL OR ANY OTHER ELEMENT, MAKE SURE IT IS PERFECTLY CLEAN.

Air filter

- Remove the fuel tank.
- Disconnect the connector from the air temperature sensor.



- Remove the oil breather pipe.



- Unscrew and remove the five screws.

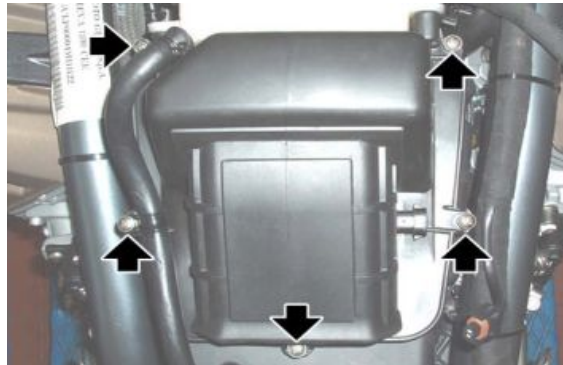

- Lift the filter casing cover.
- Remove the acoustic insulation panel.
- Remove the air filter.
- Cover the inlet duct with a clean cloth so that no foreign bodies could get into.

**NOTE**

DO NOT START THE ENGINE WITHOUT THE AIR FILTER. TO CLEAN THE FILTERING ELEMENT, USE A PRESSURE AIR JET FROM THE INSIDE TO THE OUTSIDE.

Checking the valve clearance

If the timing system is very noisy, check the clearance between valves and rocking levers.

NOTE

ADJUST WITH COLD ENGINE, WITH PISTON AT TOP DEAD CENTRE (TDC) IN COMPRESSION STROKE (VALVES CLOSED).

- Remove the fuel tank.
- Unscrew and remove the two screws.
- Remove the spark plugs protection.
- Disconnect both spark plug tubes.



- Unscrew and remove the eight screws.
- Remove the head cover.



- loosen the nut (1);
- use a screwdriver on the set screw (2) until the following clearances are obtained:
 - inlet valve: 0.10 mm (0.0039 in)
 - outlet valve: 0.15 mm (0.0059 in).
- The measurement must be done using a thickness gauge (3).

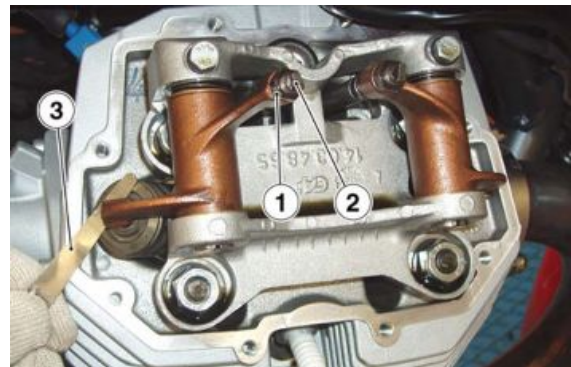

CAUTION

IF CLEARANCE IS LARGER THAN RECOMMENDED, THE TAPPET WILL BE NOISY. OTHERWISE, THE VALVES DO NOT CLOSE CORRECTLY, WHICH CAN LEAD TO PROBLEMS SUCH AS:

- PRESSURE DROP;
- ENGINE OVERHEAT;
- VALVE BURNOUT, ETC.

Braking system

Level check

Brake fluid check

- Rest the vehicle on its stand.
- For the front brake, turn the handlebar fully to the right.

- For the rear brake, keep the vehicle upright so that the fluid in the reservoir is at the same level with the plug.
- Make sure that the fluid level in the reservoir is above the "MIN" reference mark:

MIN = minimum level

MAX = maximum level

If the fluid does not reach at least the "**MIN**" reference mark:

- Check brake pads and disc for wear.
- If the pads and/or the disc do not need replacing, top-up the fluid.

Top-up

Front brake:

- Unscrew the two screws (1) of the brake fluid reservoir (2) using a Phillips screwdriver.
- Lift and remove the cover (3) and screws (1) as well.
- Remove the gasket (4).

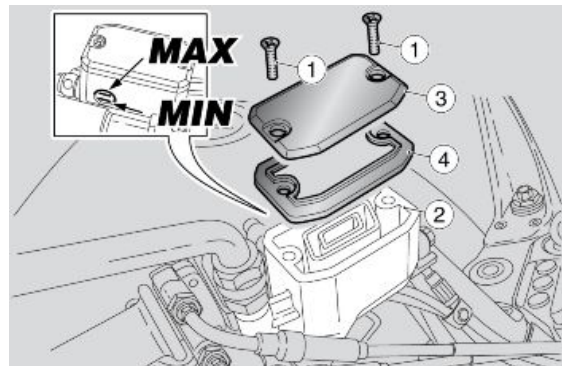

Rear brake:

- Unscrew and remove the cap (5).
- Remove the gasket (6).
- Top-up the reservoir with brake fluid to the correct level, which is between the two "MIN" and "MAX" reference marks.

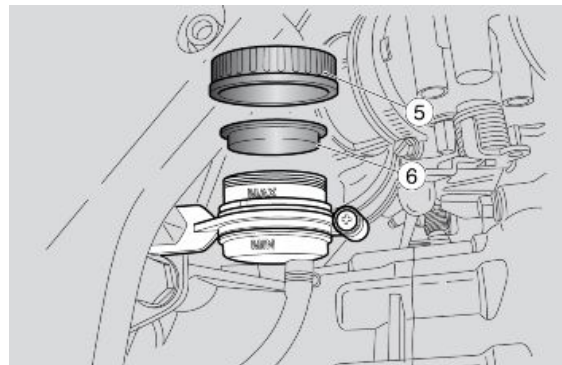

RISK OF BRAKE FLUID SPILLS. DO NOT OPERATE THE BRAKE LEVER WITH BRAKE FLUID RESERVOIR CAP LOOSENED OR REMOVED.

CAUTION



AVOID PROLONGED AIR EXPOSURE OF THE BRAKE FLUID. BRAKE FLUID IS HYGROSCOPIC AND ABSORBS MOISTURE WHEN IN CONTACT WITH AIR. LEAVE THE BRAKE FLUID RESERVOIR OPEN ONLY FOR THE TIME NEEDED TO COMPLETE THE TOPPING UP PROCEDURE.



TO AVOID SPILLING FLUID WHILE TOPPING-UP, KEEP THE TANK PARALLEL TO THE RESERVOIR EDGE (IN HORIZONTAL POSITION).

DO NOT ADD ADDITIVES OR ANY OTHER SUBSTANCE TO THE FLUID.

WHEN USING A FUNNEL OR ANY OTHER ELEMENT,
MAKE SURE IT IS PERFECTLY CLEAN.



DO NOT EXCEED THE "MAX" LEVEL MARK WHEN TOP-
PING UP.

TOP-UP TO "MAX" LEVEL MARK ONLY WHEN BRAKE
PADS ARE NEW. WHEN TOPPING UP DO NOT EXCEED
THE "MAX" LEVEL MARK WHEN BRAKE PADS ARE
WORN AS YOU RISK SPILLING FLUID WHEN CHANGING
THE BRAKE PADS.

CHECK BRAKING EFFICIENCY. IN CASE OF EXCESSIVE
TRAVEL OF THE BRAKE LEVER OR POOR PERFORM-
ANCE OF THE BRAKING SYSTEM, TAKE YOUR VEHICLE
TO AN Official Moto Guzzi Dealer, AS IT MAY BE NECES-
SARY TO PURGE THE AIR IN THE SYSTEM.

INDEX OF TOPICS

ELECTRICAL SYSTEM

ELE SYS

Components arrangement

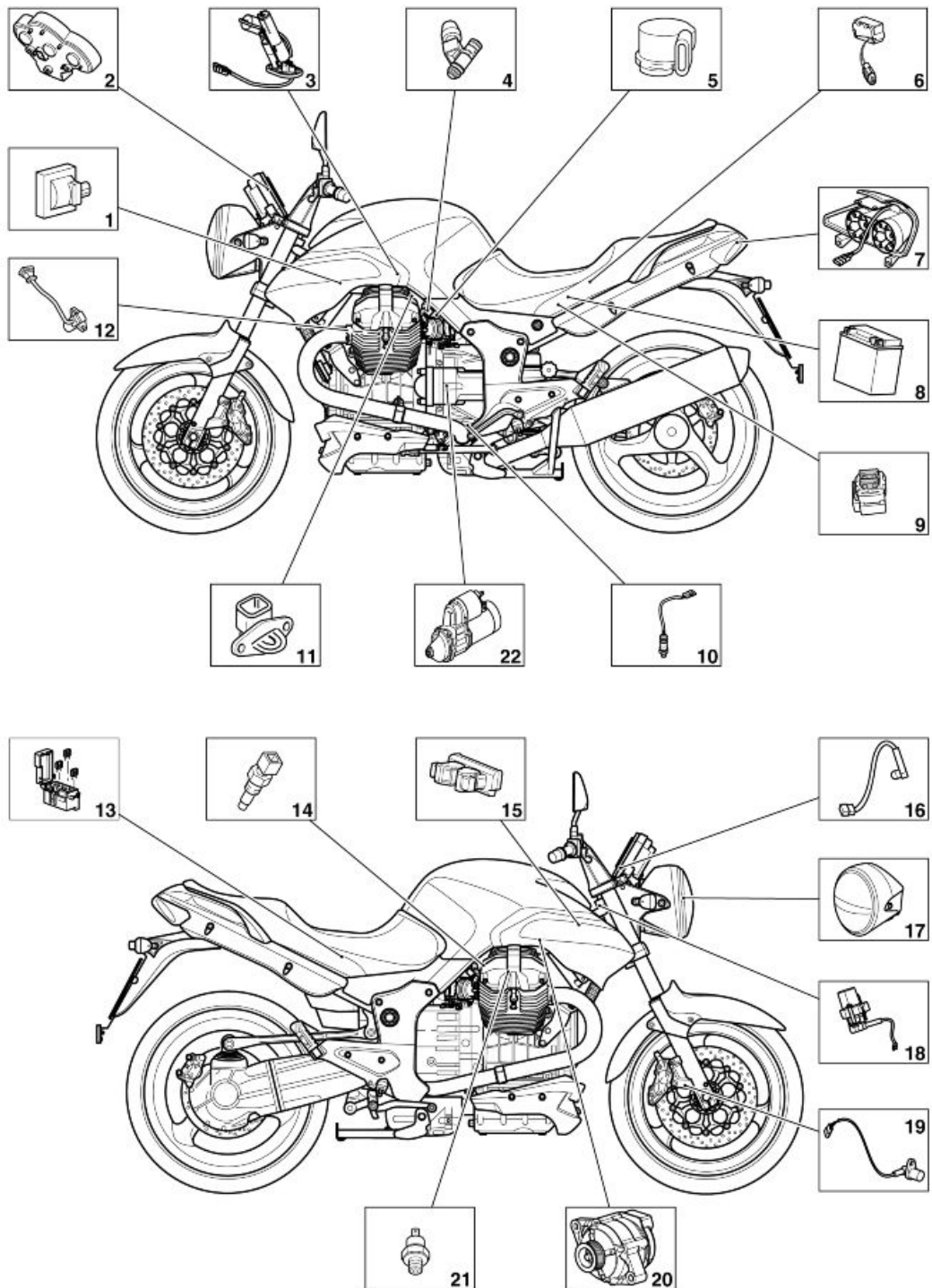

Key:

- 1 Coil
- 2 Instrument panel
- 3 Fuel pump
- 4 Injector

- 5 Throttle valve potentiometer
- 6 Fall sensor
- 7 Rear light
- 8 Battery
- 9 Main fuses
- 10 Lambda probe
- 11 Intake air temperature sensor
- 12 Engine revolution sensor
- 13 Auxiliary fuses
- 14 Head temperature sensor
- 15 Engine control unit
- 16 Instrument panel air temperature sensor
- 17 Front headlamp
- 18 Key lock with integrated immobilizer aerial
- 19 Speed sensor
- 20 Alternator
- 21 Oil pressure sensor
- 22 Starter motor

Electrical system installation

General wiring diagram

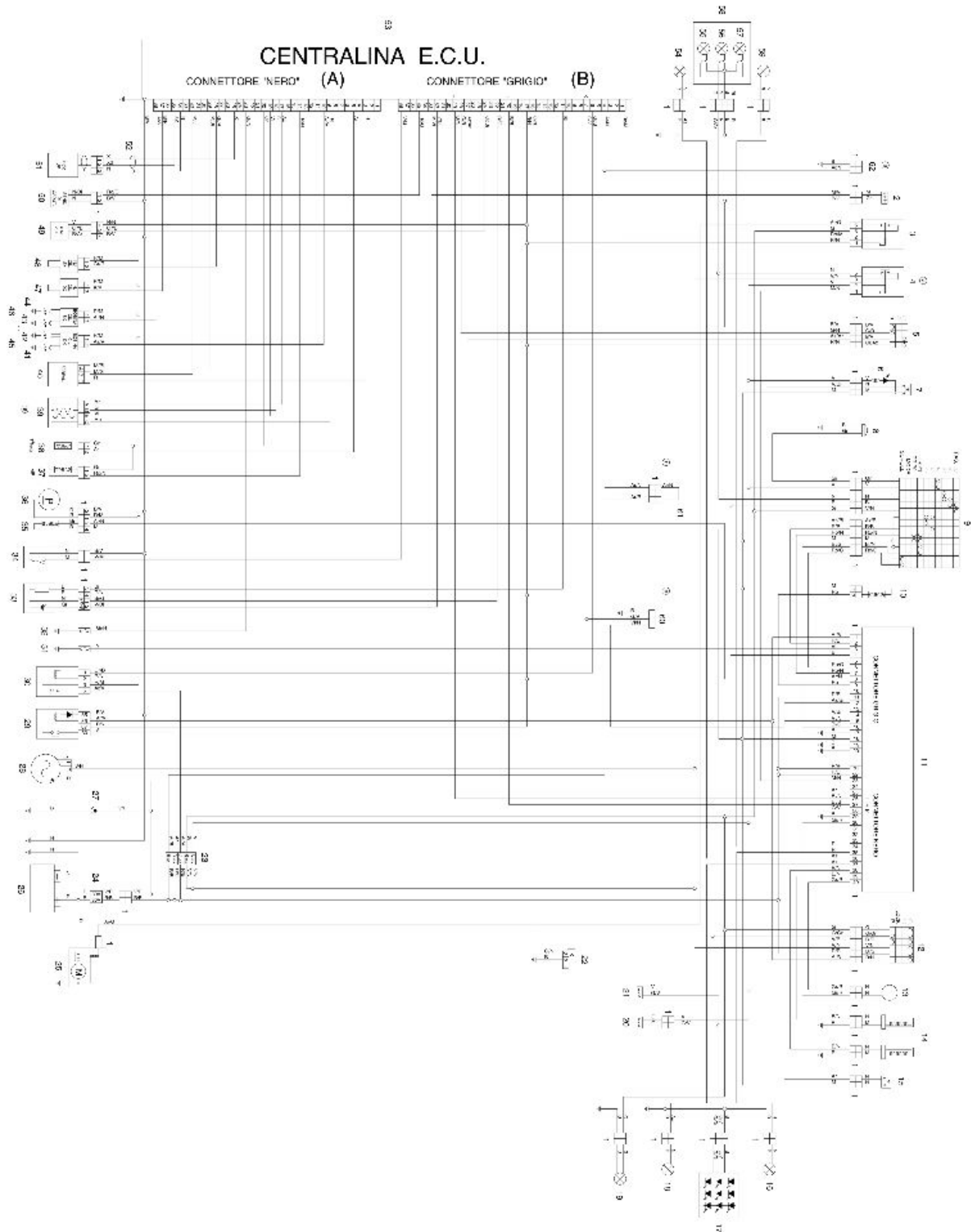

Key:

- 1. Multiple connectors
- 2. Clutch switch
- 3. Start-up relay

4. Light relay
5. Right light switch
6. HAZARD button lighting LED
7. HAZARD button
8. Horn
9. Left light switch
10. Instrument panel air temperature thermistor
11. Instrument panel
12. Key switch
13. Immobilizer aerial
14. Heated handgrips
15. Heated handgrip control
16. Right rear turn indicator
17. Rear light (LED)
18. Left rear turn indicator
19. License plate light
20. Rear stop switch
21. Front stop switch
22. Diagnosis connector
23. Auxiliary fuses
24. Main fuses
25. Starter motor
26. Battery
27. Plug socket
28. Alternator
29. Main injection relay
30. Secondary injection relay
31. Oil pressure sensor
32. Gear in neutral switch
33. Lambda probe
34. Side stand switch
35. Fuel reserve sensor
36. Fuel pump
37. Intake air temperature thermistor
38. Head temperature sensor
39. Automatic air
40. Throttle sensor
41. Right cylinder inner spark plug

- 42.Right cylinder outer spark plug
- 43.Left cylinder inner spark plug
- 44.Left cylinder outer spark plug
- 45.Right cylinder double coil
- 46.Left cylinder double coil
- 47.Right injector
- 48.Left injector
- 49.Speed sensor
- 50.Fall sensor
- 51.Flywheel pick up
- 52.Pick-up wire shielding
- 53.ECU
- 54.Left front turn indicator
- 55.Tail light bulb
- 56.Low-beam bulb
- 57.High-beam bulb
- 58.Front headlamp
- 59.Right front turn indicator
- 60.Instrument panel diagnosis
- 61.-
- 62.-
- 63.-
- 64.-
- 65.-

Cable colour:**Ar** orange**Az** sky blue**B** blue**Bi** white**G** yellow**Gr** grey**M** brown**N** black**R** red**Ro** pink**V** green**Vi** purple

Checks and inspections

Dashboard

Diagnosis

Changing the CODE

If you know the code, just enter it and then a new code that will be automatically stored in the memory.

If the vehicle is new, the user code is: 00000

Resetting the CODE

This function is used to set a new code when the old one is not available; in this case, at least two of the programmed keys have to be inserted in the ignition lock.

After the first key has been inserted, the second one is requested with the following message:

INSERT KEY II

If the second key is not inserted within 20 seconds, the operation is finished.

After recognising the second key, the new code is required with the message:

ENTER NEW CODE

Once the operation is finished, the instrument panel goes back to the SET-UP menu.

DIAGNOSIS

Access to this menu (diagnosis functions), for the technical service only, after requesting a service code.

It will read: ENTER SERVICE CODE

For Brevia 1100 with "switch" type instrument panel control, THE SERVICE CODE is: **36421**

For Brevia 1100 with "joystick" type instrument panel control, THE SERVICE CODE is: **28315**

The functions in this menu are

- Exit
- ECU errors
- Instrument Panel Errors
- Delete errors
- Reset Service
- Update
- Change Keys

ECU ERRORS

The instrument panel receives only the current errors from the control unit.

Description Error code

Throttle Valve Error DC V DC ECU 10

Throttle Valve Error DC Gnd ECU 11

Engine Temperature Error DC V DC ECU 14

Engine Temperature Error DC Gnd ECU 15

Air Temperature Error DC V DC ECU 16
Air Temperature Error DC Gnd ECU 17
Low Battery Error ECU 20
Lambda Probe Error ECU 21
Coil 1 Error DC V DC ECU 22
Coil 1 Error DC Gnd ECU 23
Coil 2 Error DC V DC ECU 24
Coil 2 Error DC Gnd ECU 25
Injector 1 Error DC V DC ECU 26
Injector 1 Error DC Gnd ECU 27
Injector 2 Error DC V DC ECU 30
Pump Relay Error ECU 36
Local Loopback Error ECU 37
Start-up Remote Error DC V DC ECU 44
Remote Error Start-up DC Gnd ECU 45
Canister Error DC V DC ECU 46
Canister Error DC Gnd ECU 47
Battery Error Hig ECU 50
Generic ECU Error ECU 51
Signal Panel Error ECU 54
Self-adaptability Value Error ECU 55
Vehicle Speed Error ECU 56
Stepper Error AC ECU 60
Stepper Error DC V DC ECU 61
Stepper Error DC Gnd ECU 62
Not recognised error ECU 00

INSTRUMENT PANEL ERRORS

In this mode a chart is displayed showing potential errors in the immobilizer and its sensors.

This is the error decoding chart:

Description Error code

Immobilizer failure: Key code

read but not recognised DSB 01

Immobilizer failure: Key code

not read (Key not present

or transponder not working) DSB 02

Immobilizer failure: Aerial

not working (Open or short-circuited) DSB 03

Immobilizer failure: Failure of

internal controller DSB 04

Fuel sensor failure DSB 05

Air temperature sensor failure DSB 06

Oil sensor failure DSB 07

Oil pressure failure DSB 08

The instrument panel keeps all previous errors stored in its **memory**.

DELETE ERRORS

This option deletes instrument panel errors only, a further confirmation is requested.

INSTRUMENT PANEL SOFTWARE UPGRADE

This function is used to program the instrument panel again with a new software through Axone. The Display reads: "Instrument panel disconnected. Now connect the diagnosis instrument"; the instrument panel will connect normally after the key is extracted-inserted.

The white connector is placed under the saddle, beside the fuse box, close to the diagnosis connector for the injection system.

Use the Ditech connector in the Axone 2000 **Aprilia-Moto Guzzi** package to connect to the Axone cable.



KEY CHANGE FUNCTION

This function can be used:

- 1) if one key is lost; the dealer can disable this key;
- 2) to activate up to 4 keys;
- 3) should a new key lock be necessary and thus program the new set of keys.

In the first phase the user code must be entered and, after confirming the inserted key (key 1) has been programmed, the other keys must be entered too.

The procedure finishes once the 4 keys have been programmed or after 20 seconds.

Should a new key lock be necessary, the procedure is: once the key is set to ON but the instrument panel does not recognise it, the user code is requested: enter the user code.

Now enter MENU, DIAGNOSIS (entering the service code), KEY CHANGE and program the new keys.

Battery recharge circuit

Checking the stator

Single-phase generator with regulated voltage

Maximum load 40A (550W)

Charging voltage 14.2 - 14.8 V (5000 rpm)

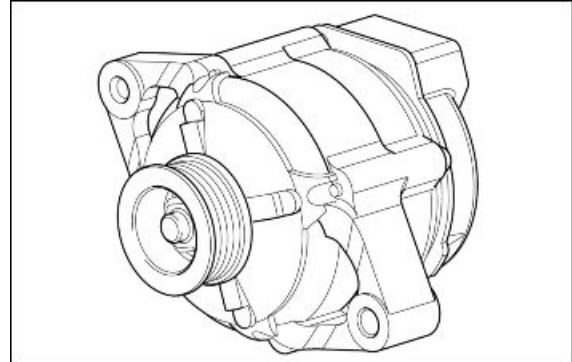

Start-up system check

pick-up input about 100 A

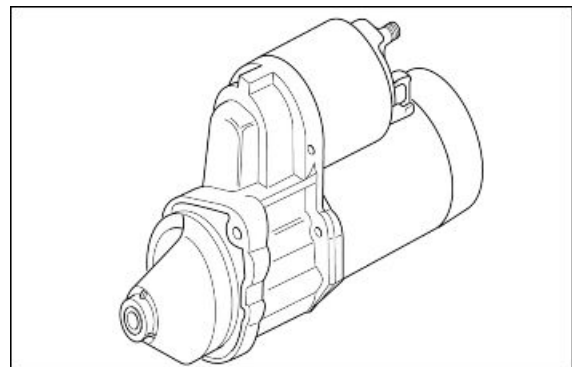

level indicators

Petrol pump:

Input: 3.5 A (to be measured between pins 1 and 2 with 12V voltage)

Fuel level sensor:

Resistance (to be measured between pins 3 and 4)

250-300 Ohm with fuel level equal to 0 litre

100 Ohm with fuel level equal to 11.25 litres (20.43 pt)

10-20 Ohm with fuel level equal to 22.5 litres (40.86 pt)

The low fuel warning light turns on with values over 230 Ohm.

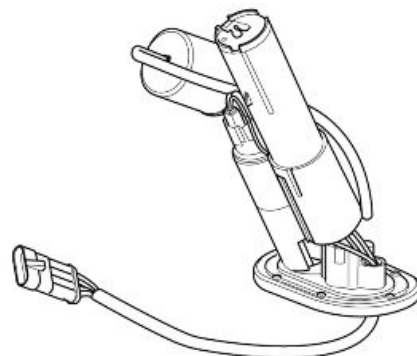

Lights list

FRONT HEADLAMP

Tail light: 12V - 5W

Low-beam light: 12 V - 55 W H7

High-beam light: 12 V - 65 W H9

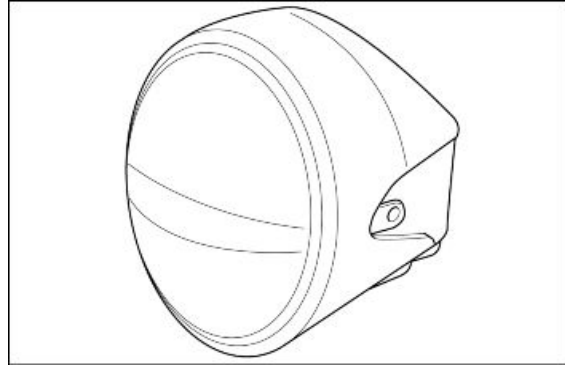

REAR LIGHT

LED

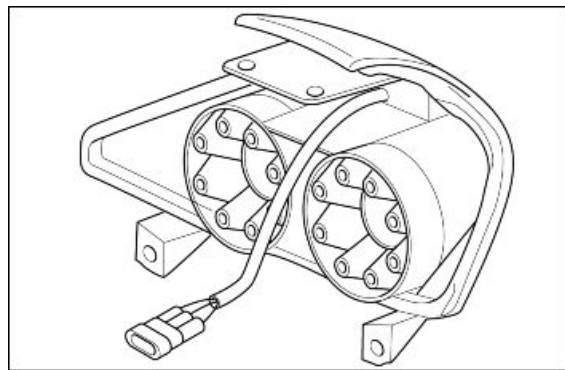

Fuses

AUXILIARY FUSES

A - Stop, horn, Hazard button illumination, light relay coil (15 A).

B - Tail lights, ignition relay coil, passing (15 A).

C - Fuel pump, coils, injectors (20 A).

D - Lambda burner, auxiliary injection relay coil, start-up relay coil, speed sensor power supply (15 A).

E - Permanent positive, ECU power supply (3A).

NOTE

THERE ARE THREE SPARE FUSES (3, 15, 20 A).

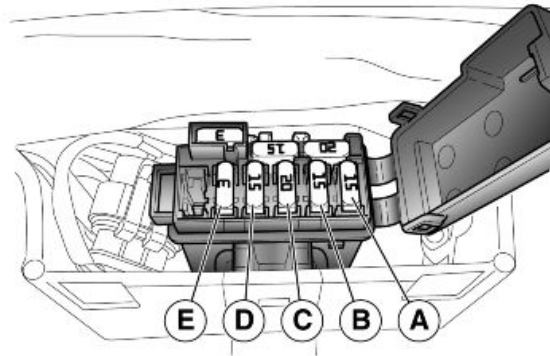

MAIN FUSES

- 1 - From battery to voltage regulator (30 A).
- 2 - From battery to key and auxiliary fuses C - D (30 A).

NOTE

THERE IS ONE SPARE FUSE.

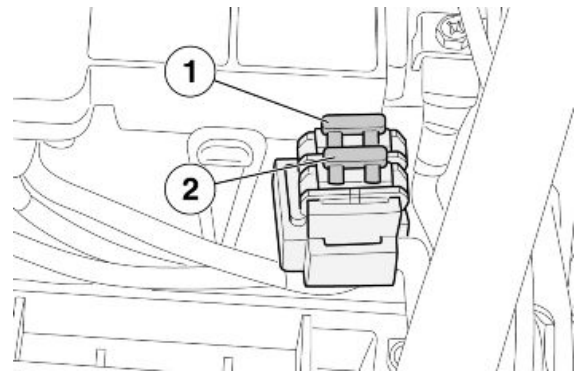
**Control unit**

Model: Magneti Marelli IAW 5 AM2

Black connector pins

Pin Use

- 1 Not used
- 2 Not used
- 3 Ignition potentiometer signal
- 4 Not used
- 5 Engine temperature signal
- 6 Not used
- 7 Not used
- 8 Not used
- 9 Stepper motor (+)
- 10 Right cylinder coil control
- 11 Not used
- 12 Not used
- 13 Not used
- 14 Air temperature signal
- 15 Not used
- 16 Not used
- 17 Stepper motor (+)
- 18 Stepper motor (-)
- 19 Stepper motor (-)
- 20 5V power supply (NTC sensors)
- 21 Not used
- 22 Not used
- 23 Neutral sensor signal
- 24 Not used

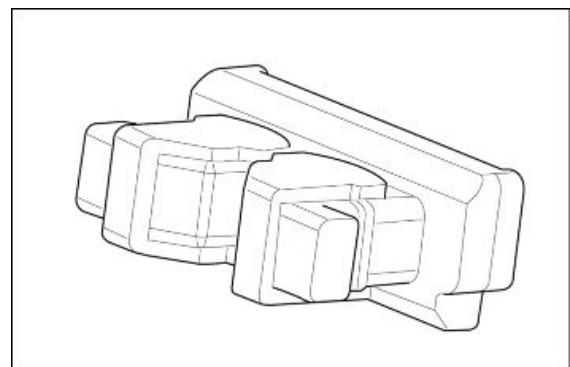

- 25 Engine revolution sensor signal
- 26 Not used
- 27 Not used
- 28 Left cylinder injector control
- 29 Ignition potentiometer power supply
- 30 Not used
- 31 Not used
- 32 Ignition potentiometer negative
- 33 Not used
- 34 Revolution sensor anti-jamming cable
- 35 Engine revolution sensor signal
- 36 Not used
- 37 Right cylinder injector control
- 38 Left cylinder coil control

Grey connector pins

Pin Use

- 1 Pin 85 ignition relay control
- 2 Not used
- 3 Not used
- 4 Power supply protected from instrument panel
- 5 Not used
- 6 Pin 86 auxiliary relay control
- 7 Immobilizer line
- 8 Pin 85 ignition relay control
- 9 Not used
- 10 Not used
- 11 Oxygen probe negative control
- 12 Not used
- 13 Not used
- 14 Not used
- 15 Not used
- 16 K line (diagnosis)
- 17 Power supply from main relay
- 18 Not used
- 19 Not used
- 20 CAN - H line (ccm/instrument panel)
- 21 Not used
- 22 Oxygen probe signal

- 23 Not used
- 24 Vehicle speed signal input
- 25 Not used
- 26 Not used
- 27 "Engine stop" signal input
- 28 Ignition signal input
- 29 CAN - L line (ccm/instrument panel)
- 30 Not used
- 31 Not used
- 32 Oxygen probe power supply
- 33 Clutch sensor signal
- 34 Not used
- 35 Fall sensor signal
- 36 Not used
- 37 Not used
- 38 Side stand sensor signal

Battery

12 V - 18 Ampere/hour

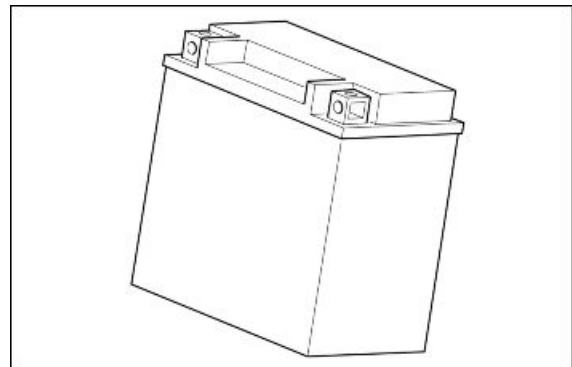

Speed sensor

Active inductive sensor
3-pin connector (Power supply - Signal-Earth connection).

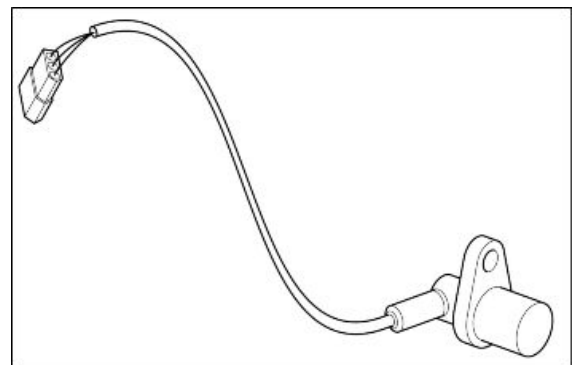

Engine rpm sensor

Measures the engine revolution speed and each cylinder timing in relation to the TDC

Inductive type sensor, with three-way connector:

- positive voltage pin;
- negative voltage pin: resistance from 650 to 720 Ohm (to be measured between pins 1 and 2);
- shielding pin.

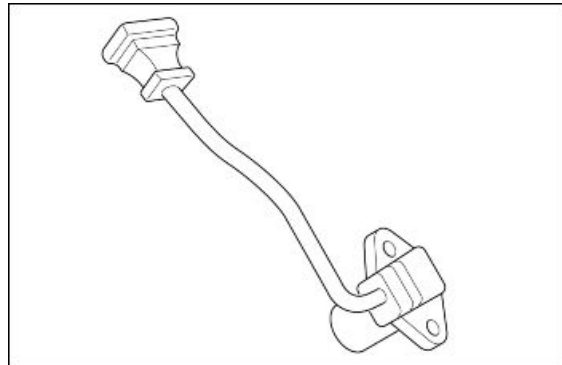

Air gap value: (measure sensor length with a depth gauge): 0.5 - 0.7 mm (0.0197 - 0.0276 in).

Throttle position sensor

Output voltage 0.55 - 4.4 V (variable depending on the position of the throttle valve, to be measured between pins C and A)

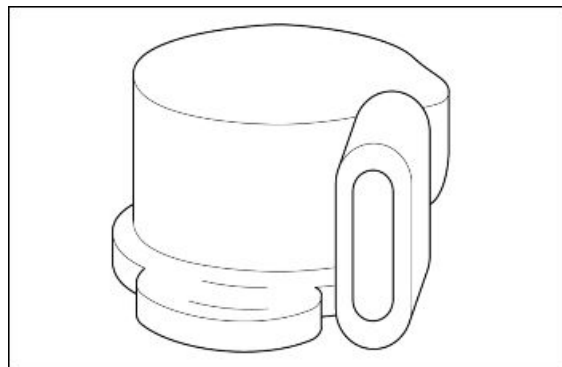

Engine temperature sensor

This sensor, 5V powered, features NTC specifications and sends the control unit a signal which varies depending on temperature to help manage the stoichiometric ratios during engine speed adjustment.

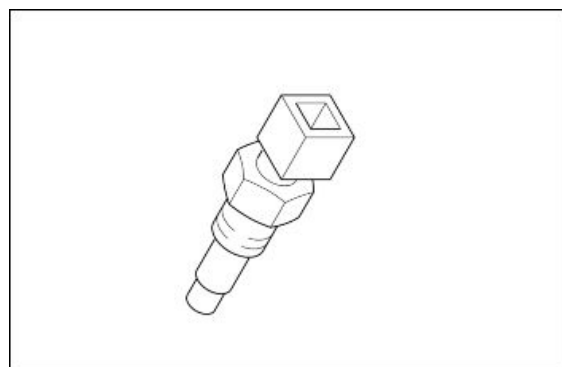

ENGINE TEMPERATURE SENSOR RESISTANCE

	Specification	Desc./Quantity
1	Resistance at -40 °C (-40 °F)	100.950 kOhm
2	Resistance at -30 °C (-22 °F)	53.100 kOhm
3	Resistance at -20 °C (-4 °F)	29.120 kOhm
4	Resistance at -10 °C (14 °F)	16.600 kOhm
5	Resistance at 0 °C (32 °F)	9.750 kOhm

	Specification	Desc./Quantity
6	Resistance at +10 °C (50 °F)	5.970 kOhm
7	Resistance at +20 °C (68 °F)	3.750 kOhm
8	Resistance at +30 °C (86 °F)	2.420 kOhm
9	Resistance at +40 °C (104 °F)	1.600 kOhm
10	Resistance at +50 °C (122 °F)	1.080 kOhm
11	Resistance at +60 °C (140 °F)	0.750 kOhm
12	Resistance at +70 °C (158 °F)	0.530 kOhm
13	Resistance at +80 °C (176 °F)	0.380 kOhm
14	Resistance at +90 °C (194 °F)	0.280 kOhm
15	Resistance at +100 °C (212 °F)	0.204 kOhm
16	Resistance at +110 °C (230 °F)	0.153 kOhm
17	Resistance at +120 °C (257 °F)	0.102 kOhm

Air temperature sensor

NTC type sensor

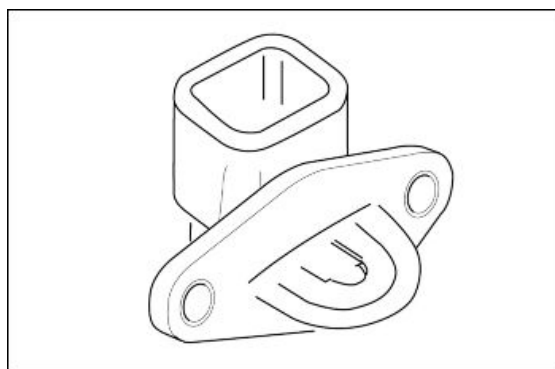

AIR TEMPERATURE SENSOR RESISTANCE

	Specification	Desc./Quantity
1	Resistance at -40 °C (-40 °F)	100.950 kOhm
2	Resistance at 0 °C (32 °F)	9.750 kOhm
3	Resistance at 10 °C (50 °F)	5.970 kOhm
4	Resistance at 20 °C (68 °F)	3.750 kOhm
5	Resistance at 30 °C (86 °F)	2.420 kOhm
6	Resistance at 40 °C (104 °F)	1.600 kOhm
7	Resistance at 90 °C (194 °F)	0.280 kOhm

Lambda sensor

Oxygen sensor with heater.

Sensor voltage between 0 and 0.9 V (to be measured between pins 1 and 2).

Heater resistance 12.8 Ohm (to be measured between pins 3 and 4 at 20°C - 68°F).

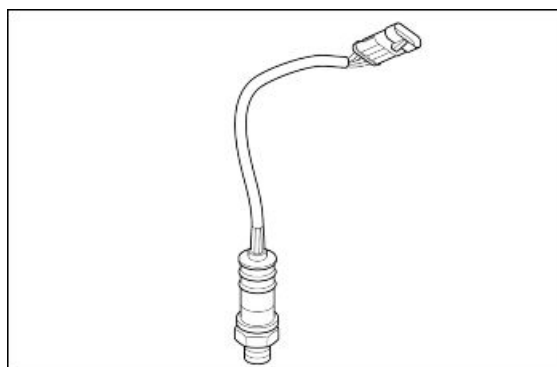

Injector

Resistance 14 Ohm \pm 2 Ohm measured at 20 °C
(68 °F)

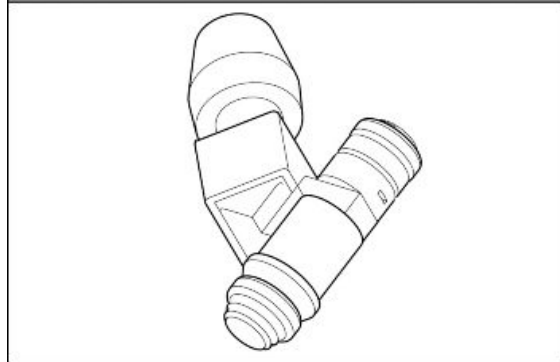

Coil

Characteristic

Primary resistance:

0.9 - 1.1 Ω (measured between pins 1 and 15)

Secondary resistance:

6.5 - 7.2 K Ω .

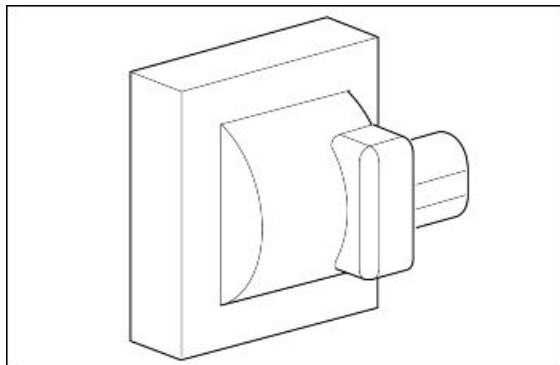

Engine oil pressure sensor

There is a failure in the oil pressure sensor when it is detected as not conducting (open) with the engine off and the key set to ON. This problem is signalled by the lighting of the "service" warning light, which should remain lit also when the engine is on.

There is an oil pressure failure indication when, with engine on and over 2000 rpm, the sensor is detected as conducting (closed). In this case, the error is indicated by the lighting of the "bulb" icon. In both cases, the instrument panel diagnosis memory is stored.

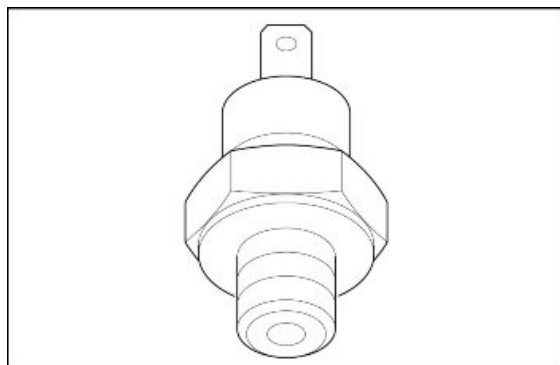

Bank angle sensor

Normally open contact, 62 kOhm resistance, with vehicle upright (straight sensor); Closed contact, 0 Ohm resistance, when the sensor is turned by 90° with respect to its fitting position.

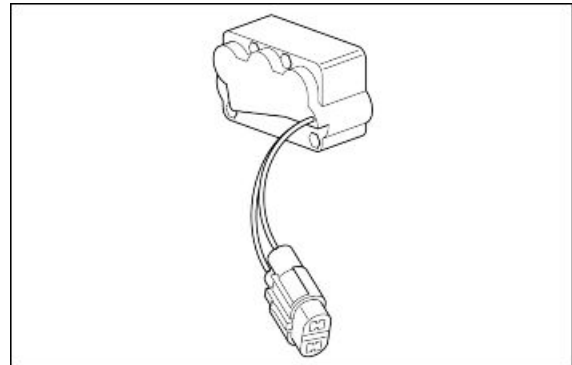

Air temperature sensor - instrument panel

Characteristic

Resistance

10 kOhm (at 25°C - 77°F)

Resistance

32.5 kOhm (at 0°C - 32°F)

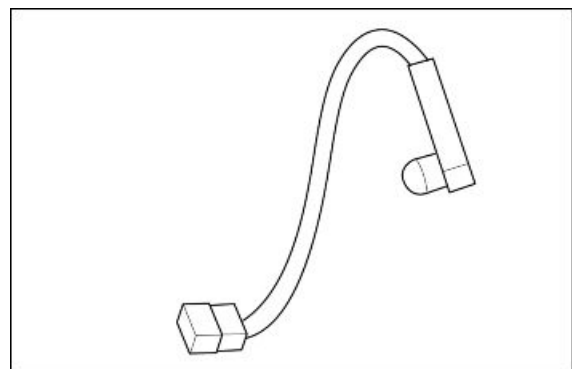

Dashboard

PIN USE

- 1 + KEY
- 2 RIGHT TURN INDICATOR CONTROL
- 3 OIL PRESSURE SENSOR
- 4 HIGH-BEAM LIGHT INPUT
- 5 -
- 6 SELECT 1
- 7 SELECT 2
- 8 FUEL LEVEL SENSOR
- 9 AIR TEMPERATURE SENSOR
- 10 -
- 11 + BATTERY
- 12 LEFT TURN INDICATOR CONTROL
- 13 -
- 14 HAZARD

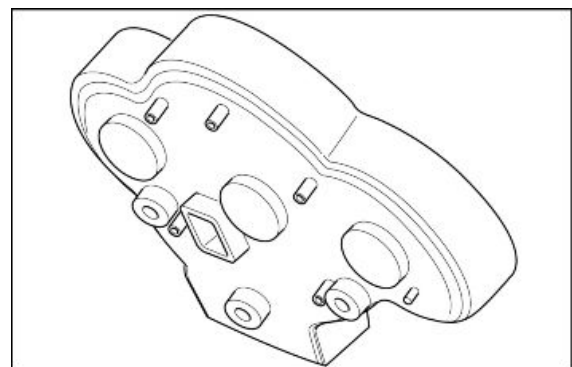

15 ANTITHEFT DEVICE LED (IF CONNECTED)
16 SELECT 3
17 SENSORS EARTH CONNECTION
18 GENERAL EARTH CONNECTION
19 GENERAL EARTH CONNECTION
20 GENERAL EARTH CONNECTION
21 + BATTERY
22 + BATTERY
23 LOW-BEAM LIGHT RELAY ACTIVATION
24 -
25 HEATED HANDGRIP CONTROL
26 CAN L
27 CAN H
28 K LINE
29 -
30 AERIAL 1
31 -
32 -
33 -
34 RIGHT REAR TURN INDICATOR ACTIVA-
TION
35 RIGHT FRONT TURN INDICATOR ACTIVA-
TION
36 LEFT REAR TURN INDICATOR ACTIVATION
37 LEFT FRONT TURN INDICATOR ACTIVA-
TION
38 LEFT HEATED HANDGRIP ACTIVATION
39 RIGHT HEATED HANDGRIP ACTIVATION
40 AERIAL 2

INDEX OF TOPICS

ENGINE FROM VEHICLE

ENG VE

Removing the engine from the vehicle

- To remove the engine block, first remove the air filter casing, the oil pan guard and disconnect the battery.
- Remove the fork and the bevel gear pair.



- Disconnect the spark plug tubes.



- Disconnect the injectors connectors.



- Disconnect the throttle cables.





- Disconnect the idle motor connector.



- Disconnect the engine temperature sensor connector.



- Disconnect the throttle valve position sensor connector.



- Disconnect the revolution sensor connector.



- Disconnect the alternator connector.



- Disconnect the neutral sensor connector.



-
- Unscrew and remove the two screws.
 - Remove the starter motor protection.



-
- Unscrew and remove the screw.
 - Disconnect the earth leads.



-
- Disconnect the starter motor connectors.



- Disconnect the Lambda probe connector.



- Place a container to collect the oil.
- Open the clutch bleed pipe.
- Drain clutch oil completely.



- Unscrew and remove the screw fixing the oil clutch pipe and collect the washer.
- Release the clutch pipe.



- Disconnect the horn connectors.



- Unscrew and remove the radiator upper fixing column.



- Unscrew and remove the lower pin nut and collect the washer.



- Remove the lower pin and collect the washer.



- Remove the centre stand.



- Loosen the clamp.



- Unscrew and remove the screws and collect the washers.



- Remove the exhaust manifolds.



- Remove the catalytic converter.



- Place the engine service stand.
- Operating from both sides, unscrew and remove the front fixing screw.
- Remove the clamps from the cable harness.

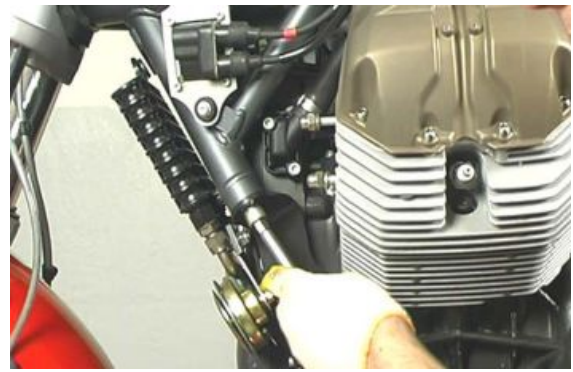

- Unscrew and remove the two screws fixing the oil vapour union tube.
- Move the oil vapour union tube aside.



- Helped by a second operator, unscrew and remove the engine upper fixing nut and collect the washer.



- Remove the upper pin and collect the washer.



- Partially lower the engine.
- Disconnect the oil pressure sensor connector.
- Lower the engine completely.

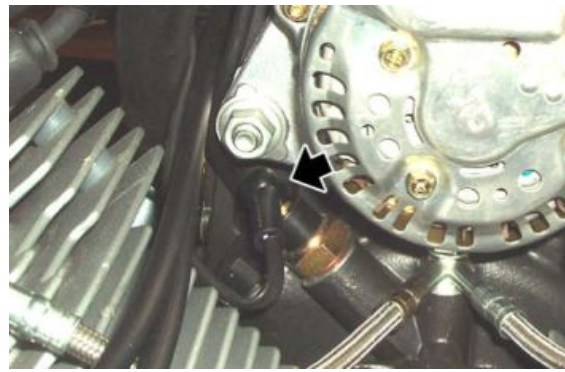

Installing the engine to the vehicle

- Fasten the vehicle chassis to a hoister and lift the engine to place it in its position.
- During this operation, restore the oil pressure transmitter connection.

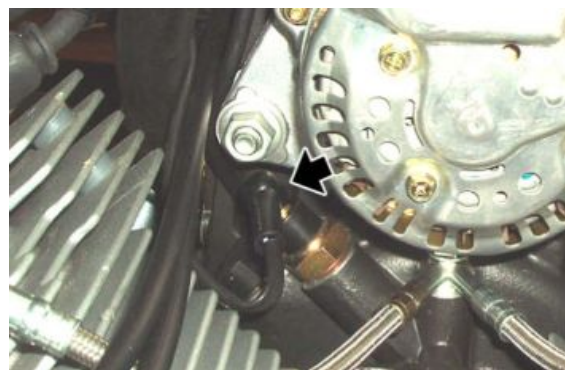

- Insert the upper pin and its washer.



- Fit the washer and tighten the engine upper fixing nut to the specified torque.



- Fit the oil vapour union tube.
- Tighten the two screws.



- Operating from both sides, tighten the front fixing screw.



- Fit the catalytic converter.



- Fit the exhaust manifolds.



- Fit the washers and tighten the nuts.



- Tighten the clamp.



- Fit the centre stand.



- Insert the lower pin and its washer.



- Fit the washer and tighten the engine lower fixing nut to the specified torque.



- Fit the oil radiator.
- Screw the upper fixing column.



- Connect the horn connectors.



- Fasten the clutch oil pipe with the screw and its washers.



- Fit the clutch bleed pipe.
- Fill up the clutch system.



- Connect the Lambda probe connector.



- Fit the starter motor connector.
- Screw the nut and place the rubber cover.



- Fit the earth leads.



- Tighten the screw.



- Fit the starter motor protection.
- Tighten the two screws.



- Connect the neutral sensor connector.



- Connect the alternator connectors.





- Connect the revolution sensor connector.



- Connect the throttle valve position sensor connector.



- Connect the engine temperature sensor connector.



-
- Connect the idle motor connector.



-
- Correctly fit the throttle cables, adjusting clearance.



-
- Connect the injector connectors.



- Connect the four spark plug tubes.



- Refit the entire fork, reaction rod, connecting rod assembly, brake calliper and the rear wheel.



INDEX OF TOPICS

ENGINE

ENG

Gearbox

Diagram

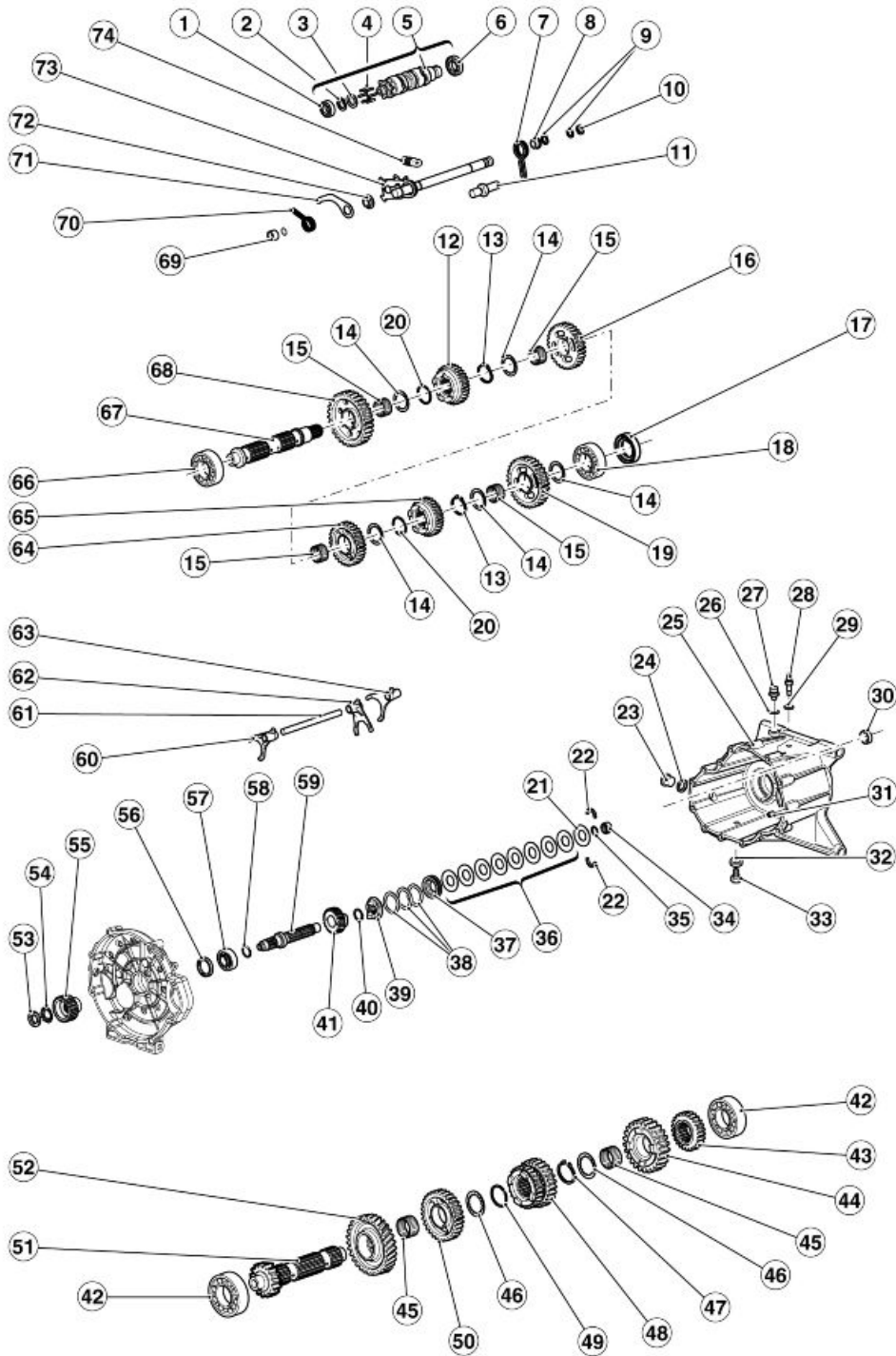

KEY:

- 1. Ball bearing
- 2. Circlip

3. Shim washer
4. Pin
5. Desmodromic compl.
6. Ball bearing
7. Spring
8. Spacer
9. Circlip
10. Fifth wheel
11. Linking pin
12. Gear
13. Circlip
14. Shoulder washer
15. Ball bearing cage
16. Gear
17. Sealing ring
18. Ball bearing
19. Gear
20. Circlip
21. Washer
22. Half ring
23. Oil cap
24. Washer
25. Gearbox
26. Aluminium gasket
27. Bleed cap
28. Neutral sensor
29. Gasket
30. Sealing ring
31. Bushing
32. Gasket
33. Oil drainage cap
34. Roller bearing
35. Circlip
36. Belleville spring
37. Pressure plate
38. Shaped washers
39. Sleeve
40. Circlip

- 41. Transmission gear
 - 42. Ball bearing
 - 43. Gear
 - 44. Gear
 - 45. Ball bearing cage
 - 46. Shoulder washer
 - 47. Circlip
 - 48. Gear
 - 49. Circlip
 - 50. Gear
 - 51. Main shaft
 - 52. Transmission gear
 - 53. Ring nut
 - 54. Washer
 - 55. Clutch internal body
 - 56. Sealing ring
 - 57. Ball bearing
 - 58. O-Ring
 - 59. Clutch shaft
 - 60. Fork
 - 61. Fork shaft
 - 62. Fork
 - 63. Fork
 - 64. Gear
 - 65. Gear
 - 66. Ball bearing
 - 67. Secondary shaft
 - 68. Gear
 - 69. Spacer
 - 70. Spring
 - 71. Index lever
 - 72. Bushing
 - 73. Pre-selector compl.
 - 74. Spring
-

Gearbox

Removing the gearbox

- Remove the starter motor.
- Make sure the transmission is in idle.
- Undo and remove the screw and remove the gearbox lever.



-
- Unscrew and remove the cap.



-
- Place a container of suitable capacity under it, unscrew and remove the cap and then bleed all gearbox oil.



-
- Unscrew and remove the three screws.

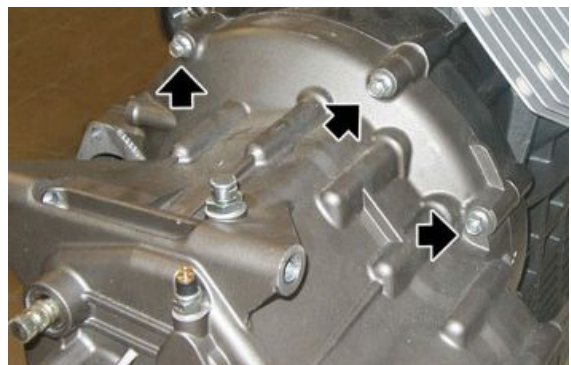

- Unscrew and remove the two screws.



- Unscrew and remove the screw.



- Remove the gearbox.



See also

[Removing the starter motor](#)
[Replacement](#)

Gearbox shafts

Disassembling the gearbox

- Remove the gearbox.



- Place the gearbox on the specific gearbox support tool and on a vice.

Specific tooling

05.90.25.30 Gearbox support

- Unscrew and slide off the odometer gear and collect the abutment washer that is inside the gearbox.



- From the outside, slide off the thrust cylinder and collect the O-Ring and the washer.



- Remove the thrust bearing and the washer.



- Slide off the two bushings (1) and remove the rod (2), collect the bushing (3).

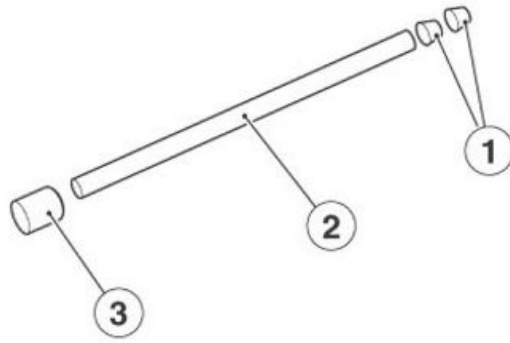

- Fold the washer fins.



- Using the adequate ring nut spanner and the clutch body locking tool, unscrew and remove the ring nut, and collect the clutch internal body.

Specific tooling

GU14912603 Hook spanner for fixing ring nut of the clutch shaft internal body

30.91.28.10 Clutch body locking

- Open the gearbox using the specific tool.

Specific tooling

05.91.25.30 Gearbox opening



- Release the spring.



- Pressing the selector, slide off the whole transmission lever.



- Unscrew and remove the threaded reference pin.

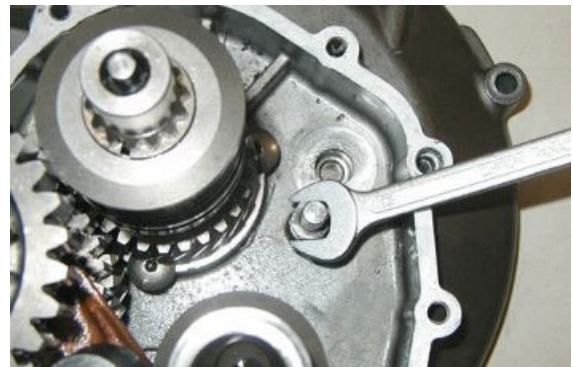

- Use rubber bands to tie down the transmission shaft unit and extract it.



- Remove the bearings from the gearbox if necessary.



- Once the transmission shaft unit is in on a bench, remove the rubber bands, being careful with the group.
- Detach the shafts and label the forks before removal.



- Remove the forks and collect the shaft.





- Replace bearings if necessary and remove the clutch shaft.



Removing the primary shaft

- Remove the main shaft.
- Operate on the main shaft from the second gear side.



- Remove the gear of the second gear and collect the ball bearing cage.



- Remove the gear of the sixth gear and collect the shoulder washer.



- Remove the circlip.



- Remove the gear of the third and fourth gears.



- Remove the circlip and collect the shoulder washer.



- Remove the gear of the fifth gear and collect the ball bearing cage.



- Heat the shaft with a specific heater and remove the helical transmission gear.



Removing the secondary shaft

- Remove the transmission shaft.
- Operate on the shaft from the grooved side.



- Remove the shoulder washer.



- Remove the gear of the second gear and collect the ball bearing cage and the shoulder washer.



- Remove the circlip.



- Remove the gear of the sixth gear.



- Remove the circlip and collect the shoulder washer.



- Remove the gear of the fourth gear and collect the ball bearing cage.



- Remove the gear of the third gear and collect the ball bearing cage and the shoulder washer.



- Remove the circlip.



- Remove the gear of the fifth gear.



- Remove the circlip, the shoulder washer and remove the gear of the first gear, collect the ball bearing cage.
- Remove the bearing if necessary.



See also

[Disassembling the gearbox](#)

Disassembling the clutch shaft

- Remove the gearbox from the engine block.
- Remove the gearbox.
- Insert the clutch shaft in the special tool for removal.

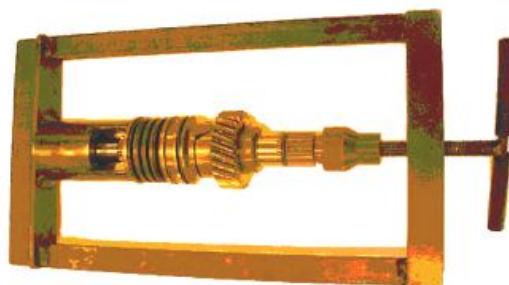

Specific tooling

000019663300 Tool for clutch shaft removal

- Compress the Belleville springs (10) until releasing the two half-rings (12).
- Remove the Belleville springs (10).
- Remove the washer (11).
- Remove the shaped washers (8).
- Remove the sleeve (7).
- Remove the circlip (6).
- Remove the transmission gear (5).
- Collect the clutch shaft (4).

CAUTION

VEHICLES WITH CHASSIS NUMBER FROM ZGULP00076M114085 TO ZGULP00076M114231 MAY PRESENT SOME NOISE PROBLEMS AT IDLE SPEED. TO REDUCE THIS NOISE, ON THE CLUTCH SHAFT, FIT TWO SHAPED WASHERS (8) BESIDES THE ONE ALREADY PRESENT IN THE ASSEMBLY

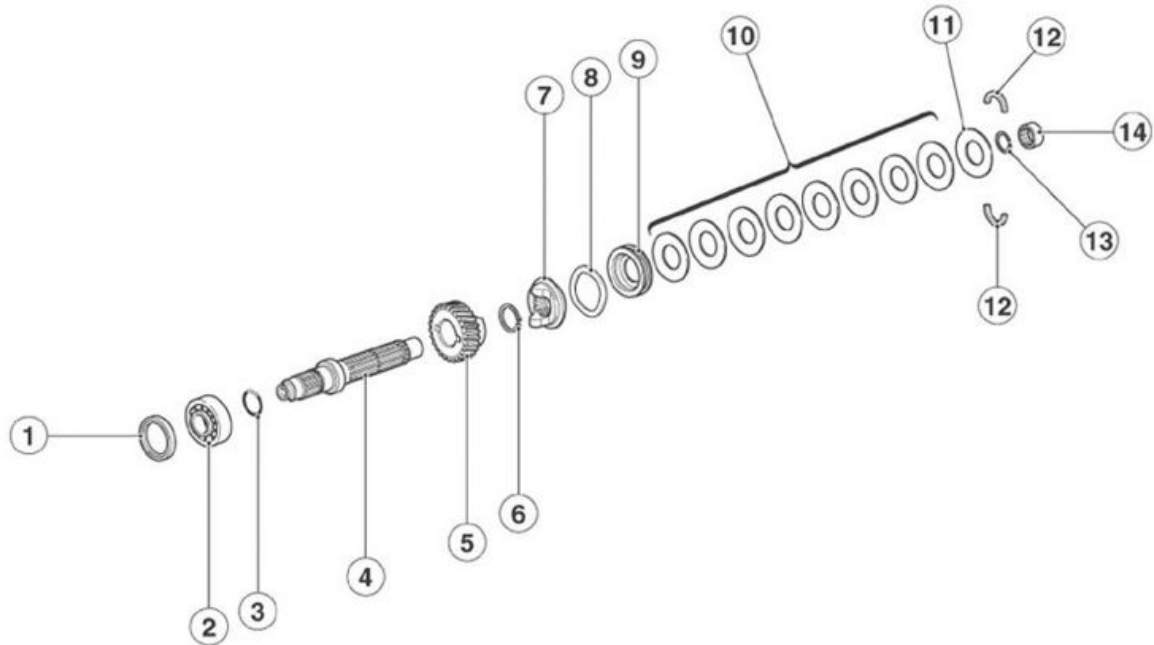

Checking the primary shaft

Measure coaxiality of the main shaft with a dial gauge and a centring device and replace it if not complying with specifications.

Characteristic

Shaft coaxiality limit

0.08 mm (0.0031 in)

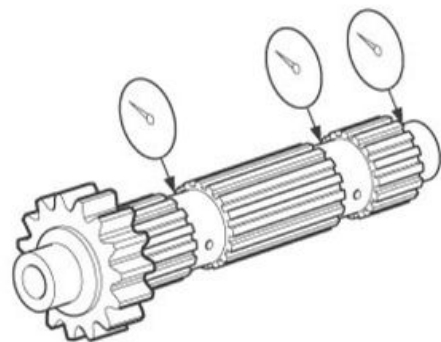

Check transmission gears for signs of pitting and wear and replace damaged gears if necessary.
Check the gear fitting teeth for cracks, damage and wear and replace those damaged if necessary.
Check the transmission gears movement and, if it is not regular, replace the damaged part.

Checking the secondary shaft

Measure the coaxiality of the transmission shaft with a dial gauge and a centring device and replace it if not complying with specifications.

Characteristic

Shaft coaxiality limit

0.08 mm (0.0031 in)

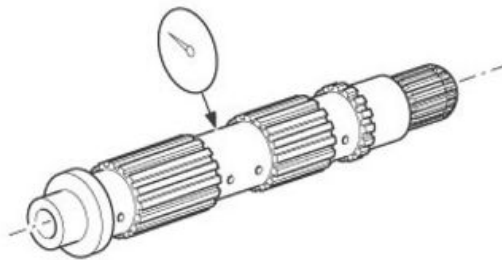

Check transmission gears for signs of pitting and wear and replace damaged gears if necessary.
 Check the gear fitting teeth for cracks, damage and wear and replace those damaged if necessary.
 Check the transmission gears movement and, if it is not regular, replace the damaged part.

Checking the desmodromic drum

Check gear drum for damage, scratches and wear and replace the desmodromic control rod if necessary.

Check the desmodromic segment «3» for damage and wear and replace it if necessary.

Check the desmodromic bearing «4» for damage and cracks and replace it if necessary.

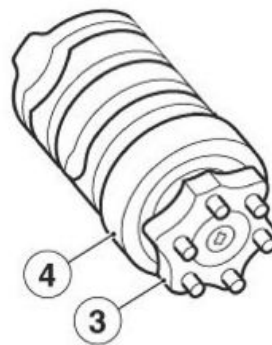

Checking the forks

NOTE

THE FOLLOWING PROCEDURE IS VALID FOR ALL GEARBOX FORKS.

- Check the transmission fork cam roller «1» and the transmission fork tooth «2» for damage, deformation and wear.
- Replace the transmission fork if necessary.

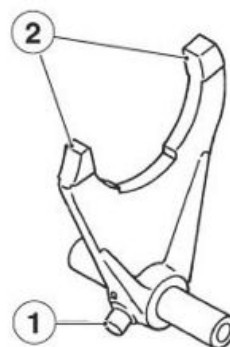

- Check the transmission fork movement and if it is not regular, replace the transmission forks.

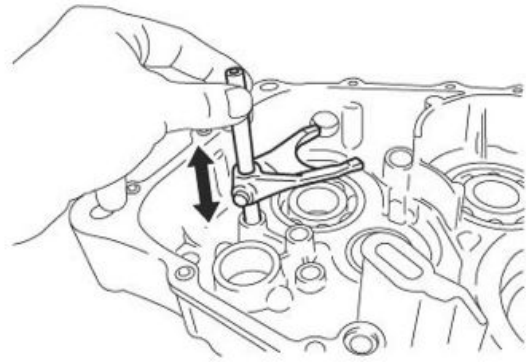
**See also**

[Disassembling the gearbox](#)

Fitting the primary shaft**NOTE**

TO REFIT, FOLLOW THE SAME INSTRUCTIONS AS FOR REMOVAL BUT IN REVERSE ORDER. REMEMBER TO REPLACE ALL SEALING RINGS, CIRCLIPS AND SAFETY RINGS PREVIOUSLY REMOVED.

See also

[Removing the primary shaft](#)

Fitting the secondary shaft**NOTE**

TO REFIT, FOLLOW THE SAME INSTRUCTIONS AS FOR REMOVAL BUT IN REVERSE ORDER. REMEMBER TO REPLACE ALL SEALING RINGS, CIRCLIPS AND SAFETY RINGS PREVIOUSLY REMOVED.

See also

[Removing the secondary shaft](#)

Assembling the clutch shaft**NOTE**

TO REFIT, FOLLOW THE SAME INSTRUCTIONS AS FOR REMOVAL BUT IN REVERSE ORDER. REMEMBER TO REPLACE ALL SEALING RINGS, CIRCLIPS AND SAFETY RINGS PREVIOUSLY REMOVED.

See also

[Disassembling the clutch shaft](#)

Assembling the gearbox**NOTE**

TO REFIT, FOLLOW THE SAME INSTRUCTIONS AS FOR REMOVAL BUT IN REVERSE ORDER. REMEMBER TO REPLACE ALL SEALING RINGS, CIRCLIPS AND SAFETY RINGS PREVIOUSLY REMOVED.

See also[Disassembling the gearbox](#)

Flywheel

Removing the flywheel

- Remove the clutch.
- Position the locking tool on the flywheel and loosen the six flywheel fixing screws operating diagonally and in stages.
- Remove the locking tool.

**Specific tooling****12.91.18.01 Tool to lock the flywheel and the starting ring gear**

- Remove the flywheel.

**See also**[Disassembling the clutch](#)

Checking

- Check that the flywheel surface that contacts the plate is not scratched.
 - Check that the contact faces on the crankshaft are not distorted; if they are, replace the flywheel.
-

Installing the flywheel

- Position the flywheel.

NOTE

RESPECT THE FLYWHEEL POSITIONING REFERENCES.

CAUTION

THE SCREWS MUST BE REPLACED WITH NEW ONES AT THE FOLLOWING REFITTING AS THEY ARE SUBJECT TO HIGH LOADS AND STRESS.

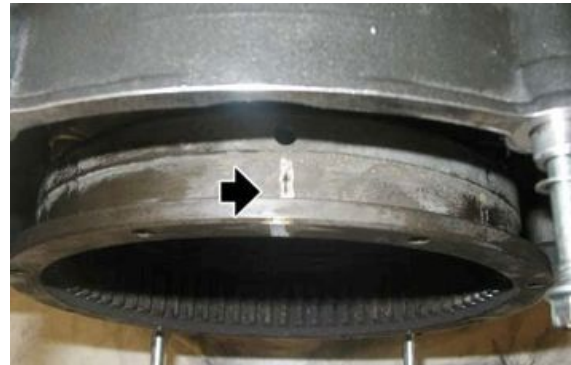

- Position the locking tool on the flywheel and tighten the six flywheel sealing screws operating diagonally and in stages.
- Fit the clutch.

**Specific tooling**

12.91.18.01 Tool to lock the flywheel and the starting ring gear

See also

[Assembling the clutch](#)

Generator

Removing the generator

- Unscrew and remove the six screws and collect the bushings.



- Remove the cover.



- Unscrew and remove the eight screws.

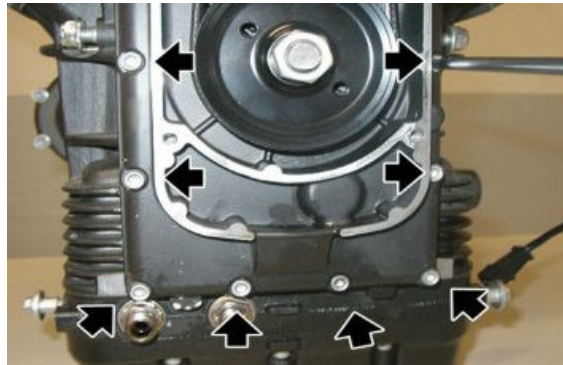

- Undo and remove the two screws.



- Unscrew the nut and collect the screw.

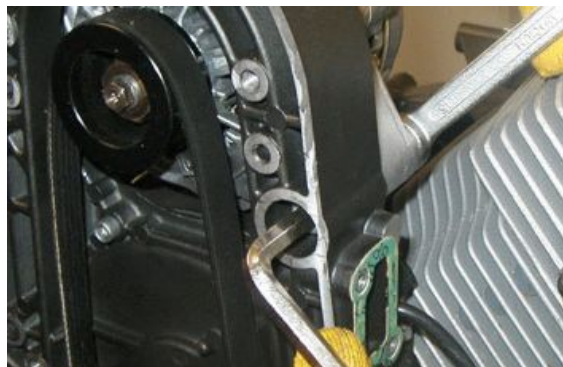

- Loosen the screw.



- Loosen the nut and undo the set screw so that the alternator slides down.



- Completely loosen and remove the screw.



- Remove the belt and the alternator with pulley.



- Using a compressed air gun, unscrew and remove the nut and collect the spacer.
- Remove the lower pulley.



- Undo and remove the two screws.



- Remove the alternator frame.
- Remove the sealing ring if necessary.



Tensioning the belt

- Remove both fuel tank side fairings.
- Remove the right exhaust manifold.
- Remove the control unit.
- Unscrew and remove the fixing screw of the engine oil scavenge reservoir.



- Unscrew and remove the spacer.



- Unscrew and remove the five fixing screws of the timing system cover.
- Remove the timing system cover.
- Loosen the set screw lock nut.



- Using the belt tensioning tool (code 05.94.86.30), tension the belt to the prescribed torque.
- Screw the set screw.
- Tighten the lock nut.



Specific tooling

05.94.86.30 Belt tension tool

Installing the generator

- If the sealing ring has been previously removed, replace it using the punch of the timing system cover sealing ring.

Specific tooling

05.92.72.30 Timing system cover sealing ring punch



- Replace the gasket and place the alternator frame using the front cover insertion cone.
- Remove the insertion cone afterwards.

Specific tooling

05.91.17.30 Front cover insertion cone



- Tighten the two screws.

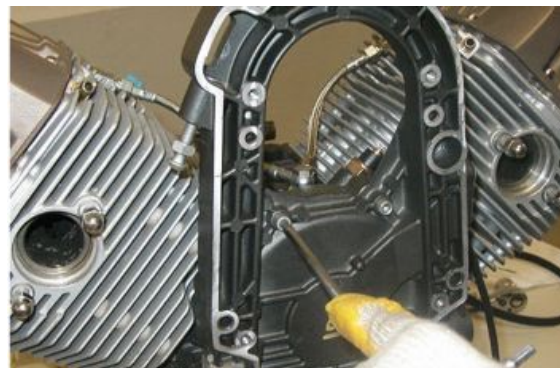

- Tighten the eight lower screws.
- Operating diagonally and in stages, tighten the ten fixing screws on the alternator fitting.

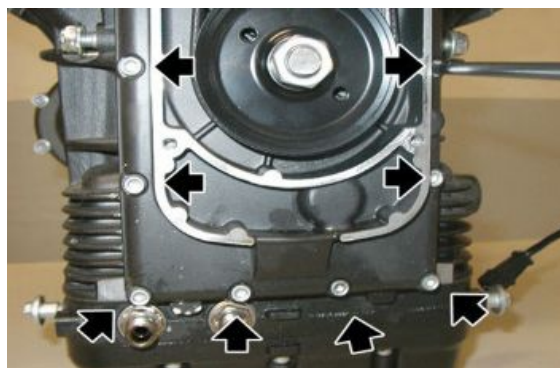

- Position the lower pulley and the spacer.
- Tighten the nut to the prescribed torque.



- Position the alternator and the timing system belt.



- Position the screw and pre-tighten it.



- Position the screw and tighten the nut.

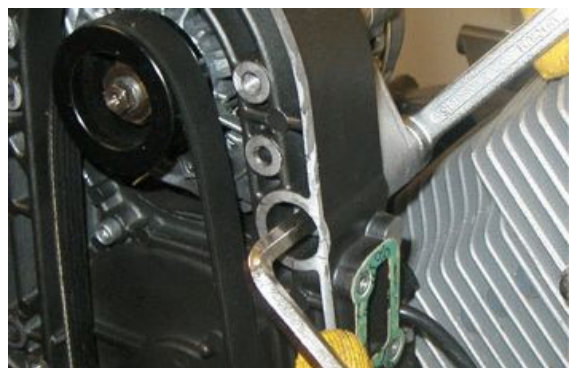

- Using the belt tensioning tool (code 05.94.86.30), tension the belt to the prescribed torque and screw the set screw.
- Remove the belt tensioning tool.
- Lock the set screw in position by screwing the lock nut.

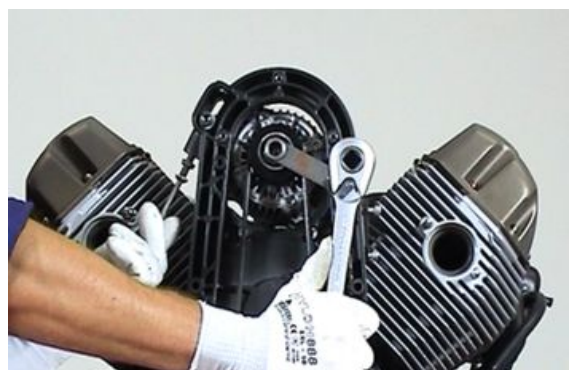

Specific tooling

05.94.86.30 Belt tension tool

- Tighten the alternator fixing screws.



- Tighten the four screws, operating diagonally and in stages.

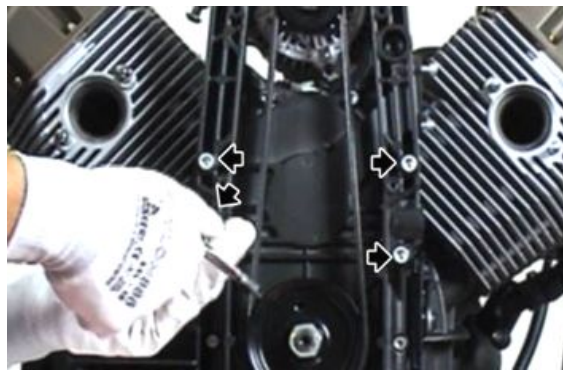

- Position the timing system cover.
- Tighten the five screws, operating in oblique direction and in stages.



Starter motor

Removing the starter motor

- Undo and remove the two screws and collect the washers.



- Slide off the starter motor.



Clutch side

Disassembling the clutch

- Remove the gearbox from the engine.
- Use the locking tool and the clutch spring compression tool on the flywheel.

Specific tooling

30.90.65.10 Tool for clutch fitting

12.91.18.01 Tool to lock the flywheel and the starting ring gear



- Undo and remove the eight sealing screws from the sprocket gear on the engine flywheel.



- Remove the start-up sprocket gear.



Extract from the inside of the engine flywheel:

- the clutch plate.



-
- The intermediate plate.



-
- The second clutch plate.



-
- The pressure plate disc cover.



- The pressure plate disc with springs.



Checking the clutch plates

Driven plates

Check that the supporting surfaces with the driven plates are perfectly smooth and even and that the external tothing that works inside the flywheel is not damaged, otherwise, replace the plate.

Crown gear for start-up

Check that the supporting surface with the driven plate is perfectly smooth and even.

Also check that the tothing where the starter motor pinion works is not chipped or scratched; otherwise, replace it.

Checking the clutch housing

Check that the teeth do not show any marks on the plate faying areas and that the tothing inside the clutch bell is in good conditions.

Checking the pusher plate

Pressure plate

Check that the plate does not show signs of wear on the opening where the control cap works, and that the supporting surfaces with the driven plate are perfectly even.

Checking the springs

Check that the springs are still flexible and are not deformed:

- Springs compressed at 22 mm (0.8661 in) must bear a load of 11.25 ÷ 11.70 kg (24.80 ÷ 25.79 pounds);
- Springs compressed at 20 mm (0.7874 in) must bear a load of 14.75 ÷ 15.30 kg (32.52 ÷ 33.73 pounds).

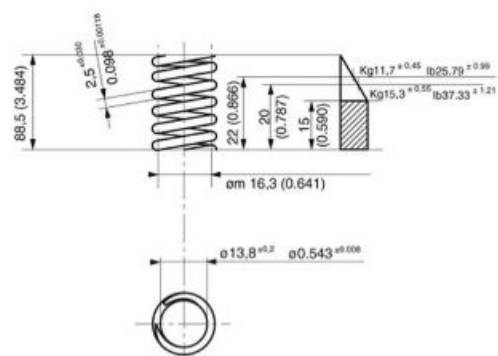

Assembling the clutch

Insert the components in the clutch bell in the following order:

- the pressure plate with springs.



- Make sure that the reference marked on the pressure plate tooth is aligned with the reference on the flywheel.



- Use the locking tool and the clutch spring compression tool on the flywheel.

Specific tooling

30.90.65.10 Tool for clutch fitting

12.91.18.01 Tool to lock the flywheel and the starting ring gear

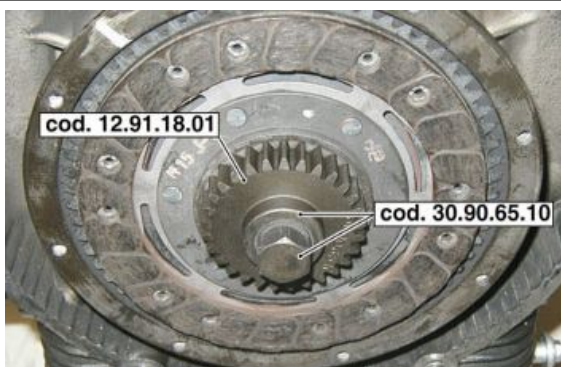

- Remove the locking tool.
- Fit the clutch disc.

Specific tooling

12.91.18.01 Tool to lock the flywheel and the starting ring gear



- The intermediate disc.



- The clutch disc.



- Place the crown gear aligning its reference with that on the flywheel.

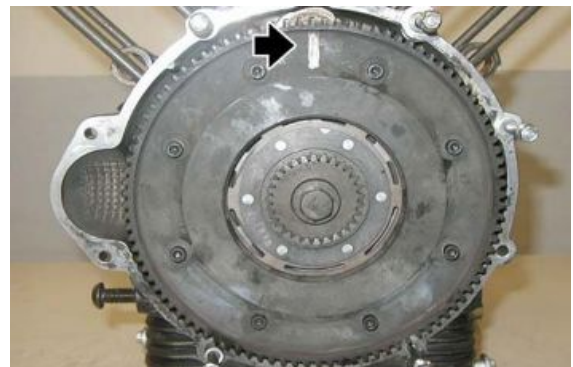

- Tighten the eight screws sealing the crown gear to the flywheel to the prescribed torque
- Remove the special tool for clutch spring compression.

Specific tooling

30.90.65.10 Tool for clutch fitting



- Insert the pressure plate disc cover.
- Install the gearbox unit.



Head and timing

Removing the head cover

NOTE

THE FOLLOWING OPERATIONS REFER TO REMOVING ONLY ONE COVER BUT APPLY TO BOTH COVERS.

- Unscrew and remove the eight screws and collect the bushings.

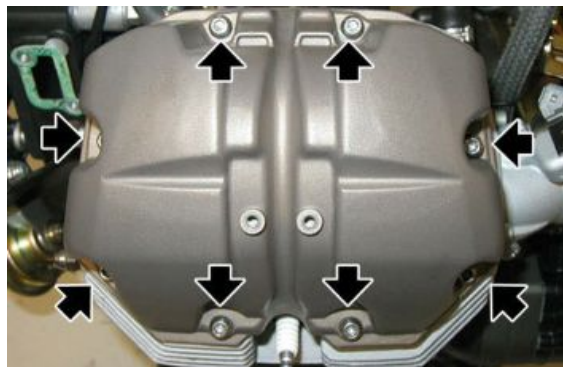

- Remove the head cover and collect the gasket.



Removing the cylinder head

- Remove the rocker rods.
- Unscrew and remove the outer spark plug.

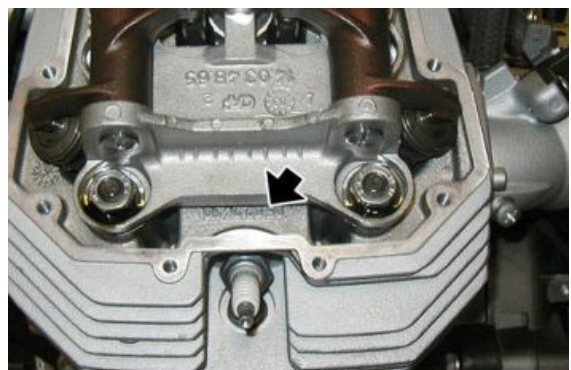

- Loosen the nut and disconnect the pipes that deliver oil to the head.



- Unscrew and remove the threaded cap.



- Unscrew and remove the joint of the pipe that delivers oil to the head and collect the washer.



- Using the suitable special tool, unscrew and remove the inner spark plug.

Specific tooling

05.90.19.30 Inner spark plug removal



- Undo and remove the two screws and collect the two washers.



- Slightly detach the cylinder head and remove the four O-rings.

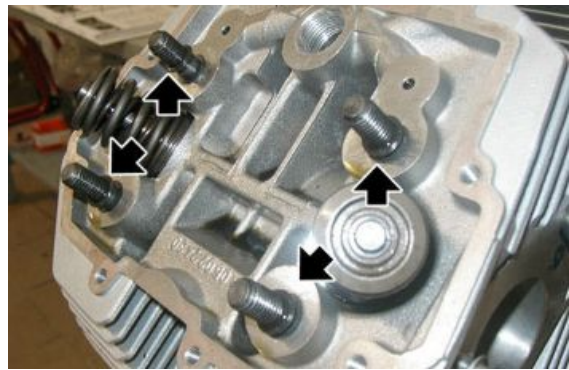

- Remove the head and collect the gasket.



Cylinder head

Removing the rocker arms

NOTE

THE FOLLOWING OPERATIONS REFER TO REMOVING ONLY ONE HEAD BUT APPLY TO BOTH HEADS.

- Remove the head cover.
- Rotate the crankshaft to TDC position in combustion phase (closed valves) for the left cylinder.
- Unscrew and remove the two screws.



- Remove the rocking lever shafts.



- Remove the rocking levers and collect the three washers.



See also

[Removing the head cover](#)

Removing the valves

- Remove the head.
- Place the special tool on the upper cap and at the centre of the head of the valve to be removed.

Specific tooling

10.90.72.00 Tool for valve removal and refitting



- Tighten the tool screw until fitted, and then hit the tool head (where the upper retainer works) with a mallet so that the two cotters (1) get detached from the upper retainer (2).
- Once the two cotters (1) are detached, screw these cotters until they can be

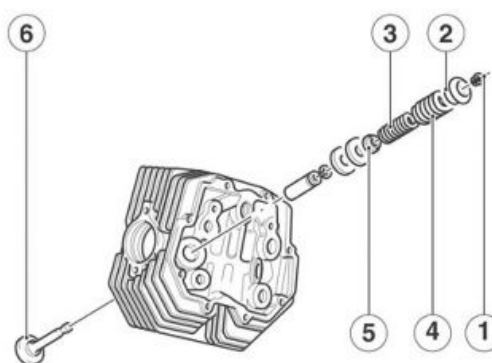

slid off the valve seats; unscrew the tool and remove it from the head.

- Remove the upper retainer (2).
- Remove the internal spring (3).
- Remove the external spring (4).
- Remove the lower retainer (5) and the shimming washers if necessary.
- Remove the valve (6) from inside the head.

Checking the valve guides

Use a punch to extract the valve guides from the heads.

The valve guides should be replaced only if the clearance between them and the stem cannot be eliminated by simply replacing the valves.

To refit the valve guides on the head, follow this procedure:

- Heat the head in an oven at approximately 60°C (140°F).
- Lubricate the valve guide.
- Fit the circlips.
- Press a punch with the valve guides.
- Use a reamer to bore the holes the valve stems slide through so that the inside diameter is at the prescribed value. The interference between the seat on the head and the valve guide must be 0.046 - 0.075 mm (0.0018 - 0.0030 in)

VALVE AND GUIDES COUPLING DATA CHART (INLET)

Specification	Desc./Quantity
Valve guide inside diameter mm (in)	8.000 ÷ 8.022 (0.3150 ÷ 0.3158)
Valve stem diameter	7.972 ÷ 7.987 (0.3139 ÷ 0.3145)
Fitting clearance mm (in)	0.013 ÷ 0.050 (0.0005 ÷ 0.0020)

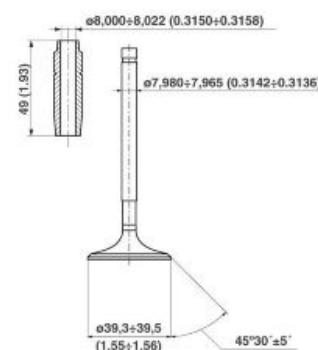
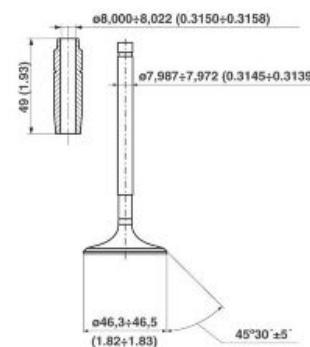

**VALVE AND GUIDES COUPLING DATA
CHART (OUTLET)**

Specification	Desc./Quantity
Valve guide inside diameter mm (in)	8.005 ÷ 8.022 (0.3152 ÷ 0.3158)
Valve stem diameter mm (in)	7.965 ÷ 7.980 (0.3136 ÷ 0.3142)
Fitting clearance mm (in)	0.025 ÷ 0.057 (0.0010 ÷ 0.0022)

Checking the cylinder head

Check that:

- The planes of contact with the cover and with the cylinder are not scored or damaged so as to compromise a perfect seal.
- Check that the clearance between the valve guide holes and valve stanchions is within the prescribed limits.
- Check the status of the valve seats.

The valve seats should be reamed with a mill. The seat inclination angle is 45° +/- 5'. After milling, it is necessary to grind them to ensure a good coupling and a perfect sealing between the ring nuts and the valve heads.

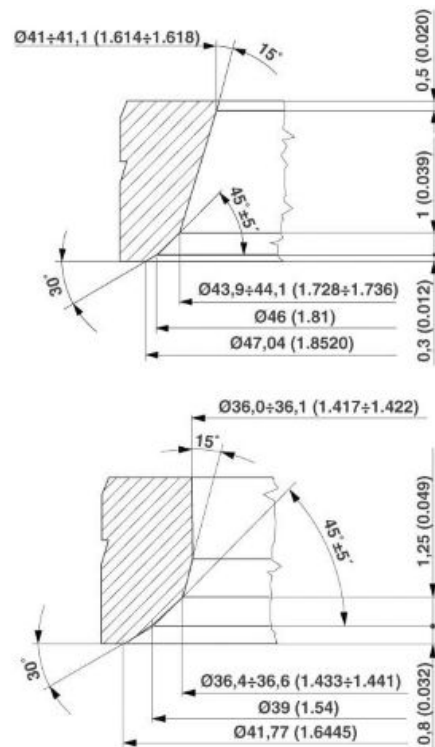

Installing the valves

NOTE

THE FOLLOWING OPERATIONS REFER TO REMOVING ONLY ONE HEAD BUT APPLY TO BOTH HEADS.

- Place the valve (6) inside the head.
- Place the lower retainer (5) and the shimming washers.
- Place the external spring (4).
- Place the internal spring (3).
- Insert the upper retainer (2).
- Place the two cotters (1) on the seats on the valves.
- Compressing the spring with the special valve tool, install the valve cotters.

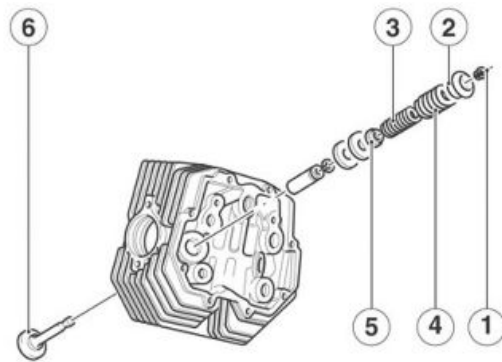

Specific tooling

10.90.72.00 Tool for valve removal and refitting

NOTE

UPON REFITTING, PLACE THE O-RING CORRECTLY ON THE VALVE.



- Remove the special tool



Installing the rocker arms

CAUTION

UPON REFITTING, ALWAYS REPLACE THE O-RINGS



CAUTION

UPON REFITTING, DO NOT INVERT THE POSITION OF THE ROCKING LEVER SUPPORTS SO AS NOT TO COMPROMISE LUBRICATION.

CAUTION

THE NEW LUBRICATION SYSTEM IS VALID FROM ENGINE NUMBER N° KP15051 ON.

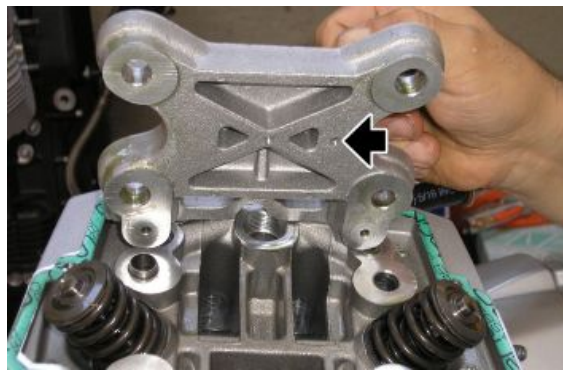

- Install the rocking lever rods if they have been previously removed.
- Install the rocking lever support and replace the four O-rings.



- Place the four washers and screw the four nuts.



-
- Place the six washers and install the rocking levers.

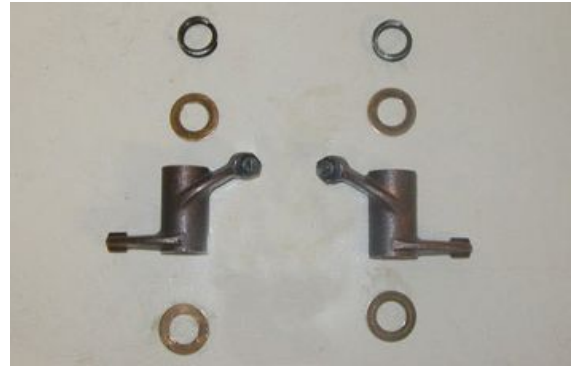

-
- Insert the rocking lever shafts.



-
- Rotate the crankshaft to TDC position in combustion phase (closed valves) for the left cylinder.
 - Tighten the two screws.



See also

[Installing the rods](#)

Timing

Chain removal

- Remove the engine assembly.
- Remove the alternator.
- Clearly indicate the distribution timing marks that should be restored at the next refitting (left cylinder TDC).



- Using the adequate tool, lock the ignition crown.

Specific tooling

12.91.18.01 Tool to lock the flywheel and the starting ring gear



- Unscrew the central sealing nut of the camshaft gear and collect the washer.



- Remove the cotter.



- Unscrew and remove the central sealing nut of the timing system control gear on the crankshaft and collect the washer.



- Unscrew and remove the oil pump gear nut and collect the washer.



- Remove the chain tensioner and collect the spring.
- Slide off the three gears together with the chain.

CAUTION

BE CAREFUL WITH THE OIL PUMP PULLING COTTER.

**See also**

[Removing the engine from the vehicle](#)

Removing the rods

- Remove the rocking levers.
- Unscrew and remove the four nuts and collect their washers.



- Remove the rocking lever support.



- Remove the two rocking lever rods

**See also**

[Removing the rocker arms](#)

Removing the tappets

- Remove the engine assembly.
- Remove both heads.
- Slide off and remove the tappets from their seat on both sides.

**See also**

[Removing the engine from the vehicle](#)

Removing the phonic wheel

- Remove the timing chain.
- Slide off the tone wheel and collect the plug.



See also

Chain removal

Removing the camshaft

- Remove the timing chain.
 - Remove the tone wheel.
 - Remove the tappets.
 - Remove the rods.
-
- Unscrew and remove the three screws and collect the washers.

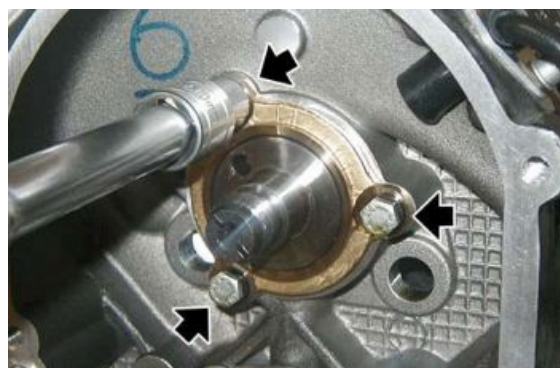

-
- Remove the flange.



- Remove the camshaft.



See also

Chain removal

[Removing the phonic wheel](#)

[Removing the tappets](#)

[Removing the rods](#)

Installing the camshaft

NOTE

FOR TIMING SYSTEM REFITTING, IT IS NECESSARY TO HEAT THE ENGINE WITH A SUITABLE HEATER IN ORDER TO INSERT THE CAMSHAFT CORRECTLY AND WITHOUT DAMAGING IT.

Follow the camshaft removal instructions but in reverse order.

Installing the rods

- Install the head if it has been previously removed.
- Replace the four O-rings.

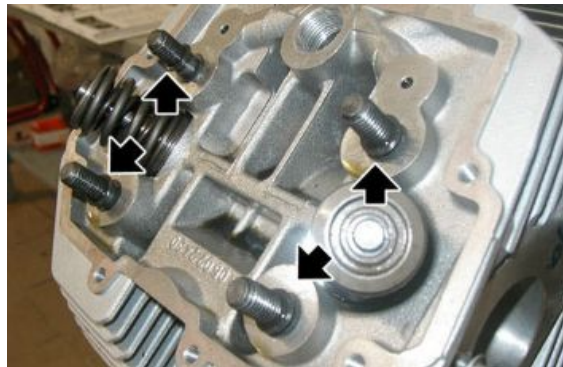

- Install the two rocking lever rods.



Installing the chain

For the installation of the three gears and of the timing chain carry out the operations indicated in section "Timing".

Cam timing

- On the crankcase, fit the crankshaft and the camshaft.
- Fit the cylinders and the heads.
- Fit the rods.
- Do not fit the rocking levers before carrying out engine timing so as not to damage the valves during the rotation of the camshaft.
- Turn the crankshaft until the left cylinder piston reaches the top dead centre (TDC).
- Fit the flywheel on the crankshaft aligning the stamp arrow on the flywheel with the fixed reference on the crankcase.

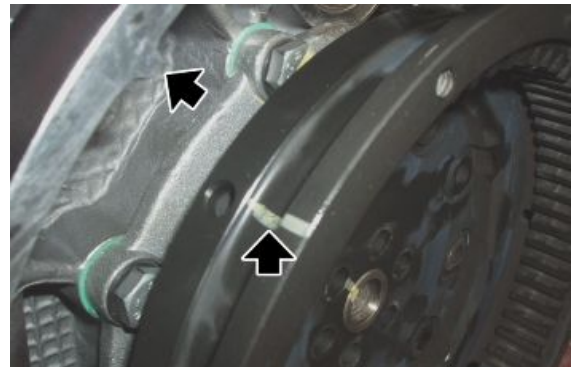

- Position the locking tool on the flywheel and tighten the six flywheel sealing screws operating diagonally and in stages.
- Fit the clutch.



Specific tooling

12.91.18.01 Tool to lock the flywheel and the starting ring gear

- Fit the plug on the camshaft.
- Introduce the tone wheel with the smooth side facing outward.



- Place the shim washer adequately so that the timing chain do not wear out the crankcase.
- Fit the three timing system gears and the chain aligning the references on the camshaft and crankshaft gears.



- Introduce the belleville spring and the nut to fasten the camshaft gear.



- Introduce the washer and the nut to fasten the crankshaft gear.



- Turn the oil pump shaft and introduce the gear pulling woodruff key.

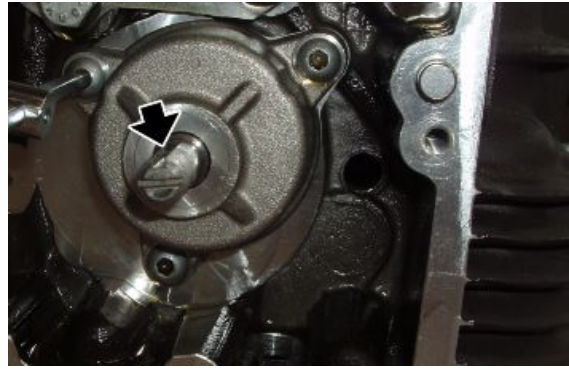

- Introduce the chain tensioner.



- Remove the flywheel locking tool.
- Check the crankshaft rotation.
- Fit the rocking levers.

Specific tooling

12.91.18.01 Tool to lock the flywheel and the starting ring gear

Timing

To check distribution timing, follow these instructions:

- Obtain a clearance between rocking levers and valves equal to 1.5 mm (0.059 in);
- Place the hub for graduated dial and the relative graduated dial on the crankshaft slot, inserting the spacer and fixing it to the shaft with the nut.

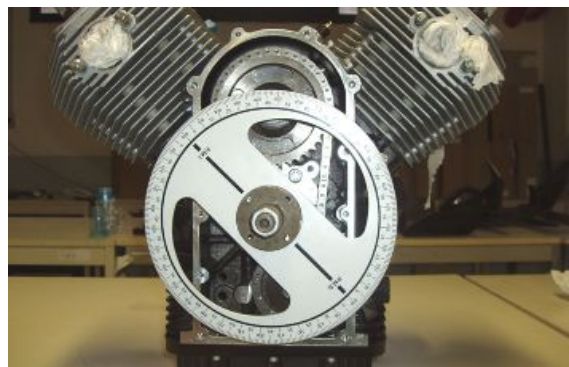

Specific tooling

981006 Graduated dial hub

19.92.96.00 Graduated dial to control ignition timing

- With a screw, fasten the specific arrow to the threaded hole to the left of the crankcase.

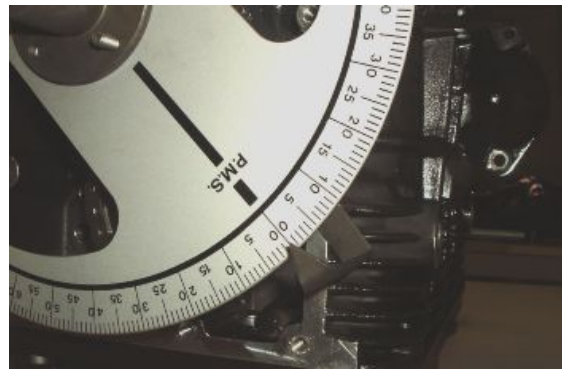

Specific tooling

17.94.75.60 Arrow to control ignition timing

- Fit the dial gauge support and then the gauge itself on the left outer spark plug hole.



- Rotate the crankshaft until the left cylinder piston is actually at the top dead centre (with valves closed).
- Reset the dial gauge and make sure the references (on the timing system gears and the engine pinion) are perfectly aligned, so that looking through the checking hole on the gearbox, the reference line marked 'S' is perfectly aligned with the reference marked at the centre of the hole.
- Align the arrow point with the TDC zero on the graduated dial.

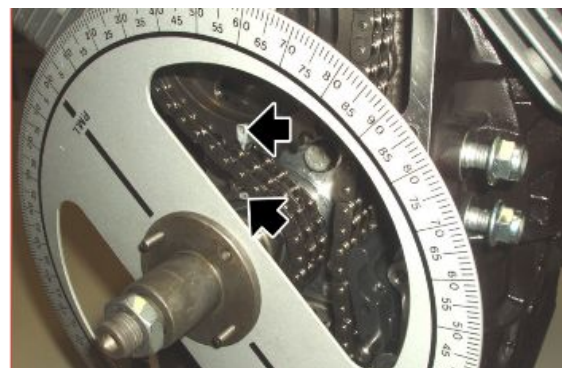

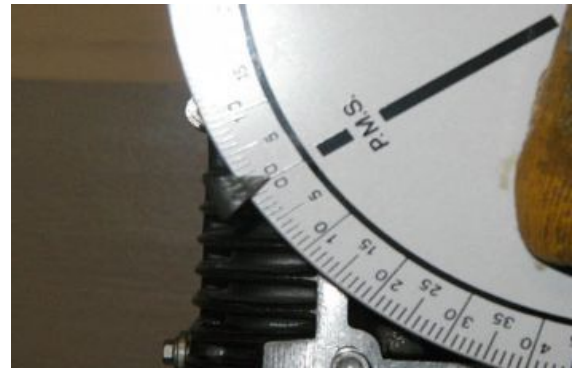

- Observing the timing system diagram, check timing considering that:

A - intake start opens 22° before TDC

B - exhaust end closes 24° after TDC

C - exhaust start opens 52° before BDC

D - intake end closes 54° after BDC

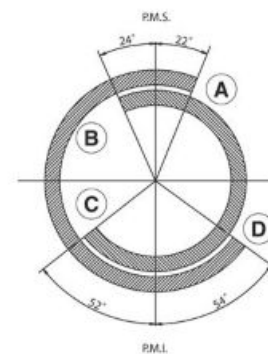

- Screw the dial gauge support and then the gauge itself on the right cylinder outer spark plug hole.
- With a screw, fix the arrow to the threaded hole to the right of the crankcase.
- Turn the disc clockwise until the reference marked with letter 'D' is aligned with the reference at the centre of the checking hole on the gearbox (valves closed).
- Repeat the operations described above for the left cylinder.



- After the check and if everything is correct, operate as follows to restore the operation clearance between rocking levers and valves (intake 0.10 mm (0.0039 in), outlet 0.15 mm (0.0059 in)).
- Remove the graduated dial hub, the graduated dial, the arrow, the dial gauge support and the gauge itself.

- Refit the spark plugs and finish the refit.

Specific tooling

981006 Graduated dial hub

19.92.96.00 Graduated dial to control ignition timing

17.94.75.60 Arrow to control ignition timing

Measuring air gap

- Undo and remove the two screws and remove the sensor.



- Insert a suitable plain washer on the sensor and note its thickness.



- Place the sensor on the timing system cover and cause it to make contact with the tone wheel.



- Measure the clearance between the fixing plate and the cover with a feeler gauge. Subtract the plain washer value from this measurement to obtain the clearance between the sensor and the tone wheel.



- Remove the washer and fit the sensor after applying adequate sealing paste on the fixing plate, then tighten the screws to the prescribed torque.

Cylinder-piston assembly

Removing the cylinder

NOTE

THE OPERATIONS DESCRIBED BELOW REFER TO ONE HEAD REMOVING ONLY BUT APPLY TO BOTH HEADS.

- Remove the head.
- Slide off the gasket.



- Slide off the cylinder from the stud bolts, paying attention not to damage the piston.



See also

[Removing the cylinder head](#)

Disassembling the piston

NOTE

THE OPERATIONS DESCRIBED BELOW REFER TO ONE HEAD REMOVING ONLY BUT APPLY TO BOTH HEADS.

- Remove the cylinder.
- Cover the crankcase opening with a clean cloth.
- Release the snap ring.



- Remove the pin.



- Mark the piston crown on the exhaust side so as to remember the refitting position.
- Remove the piston.



See also

[Removing the cylinder](#)

Fitting the piston

NOTE

THE OPERATIONS DESCRIBED BELOW REFER TO REMOVING ONLY ONE HEAD BUT APPLY TO BOTH HEADS.

- Fit the piston.

NOTE

CHECK THE ORIENTATION OF THE PISTON ACCORDING TO THE REFERENCES AT THE TOP. DO NOT ASSEMBLE PISTONS AND CYLINDERS OF DIFFERENT SELECTOR TYPES.



- Insert the pin.



- Insert the pin clip.



Installing the cylinder

- Fit the piston.
- Remove the cloth used to prevent foreign bodies coming into the crankcase.
- Turn the rings so that the junction ends are 120 degrees from each other.
- Lubricate piston and cylinder.
- Using a specific tool for piston ring clamps, place the cylinder.

CAUTION

DURING THIS OPERATION, PAY ATTENTION NOT TO DAMAGE THE PISTON.

Specific tooling

05.92.80.30 Piston ring clamp

- Remove the piston ring clamp tool and finish positioning the cylinder.

Specific tooling

05.92.80.30 Piston ring clamp



CAUTION

UPON REFITTING DO NOT INVERT THE POSITION OF THE CYLINDER GASKET SO AS NOT TO COMPROMISE LUBRICATION.

CAUTION

THE NEW LUBRICATION SYSTEM IS VALID FROM ENGINE NUMBER N° KP15051 ON.



- Place the gasket on the cylinder base.



- Fit the head.

See also

[Fitting the piston](#)
[Installing the cylinder head](#)

Installing the cylinder head

- Fit the valves if they have been previously removed.
- Replace the gasket between head and cylinder.
- Fit the head.



- Place the two washers and tighten the two screws.





- Using the suitable special tool, screw the inner spark plug.

Specific tooling

05.90.19.30 Inner spark plug removal



- Insert the washer and screw the joint of the pipe that delivers oil to the head .



- Screw the threaded cap.



- Connect the pipes that deliver oil to the head and screw the nut.



- Install the outer spark plug.

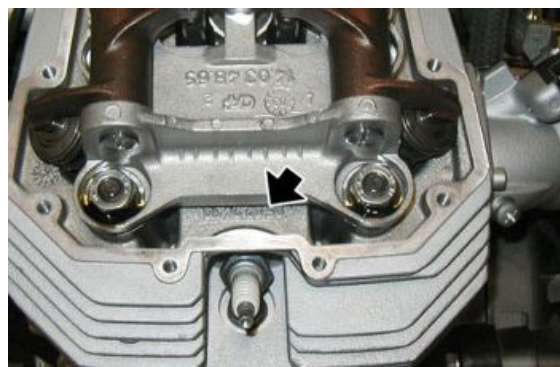

- Replace the gasket and install the head cover.

**See also**

[Installing the valves](#)

[Installing the head cover](#)

Installing the head cover

- Replace the gasket and fit the head cover.
- Place the bushings and cross tighten the eight screws.

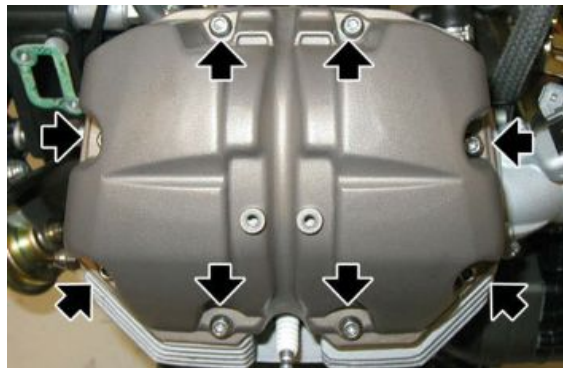

Crankcase - crankshaft

Removing the crankshaft

- Remove the connecting rods.
- Undo and remove the eight fixing screws and collect the washers.



- Hold the crankshaft during flange removal.
- Using the suitable special tool, remove the crankshaft flange.
- Remove the sealing ring from the flange, if necessary.

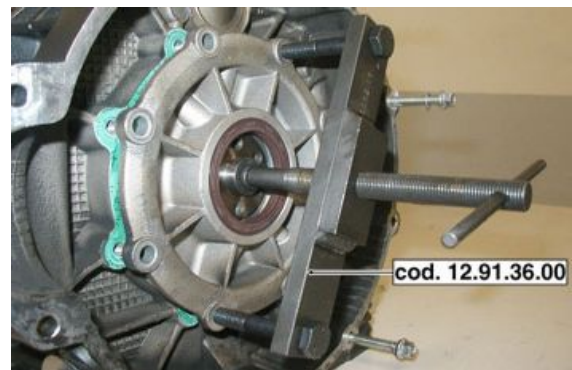

Specific tooling

12.91.36.00 Tool to remove the flywheel-side flange

- Remove the crankshaft afterwards.



See also

[Disassembling the connecting rod](#)

Disassembling the connecting rod

- Remove the heads.
- Remove the cylinders and the pistons.
- Remove the clutch.
- Remove the flywheel.
- Remove the timing system.
- Remove the oil sump.
- Loosen the coupling screws 'A' from inside the crankcase and remove the connecting rods 'B'.

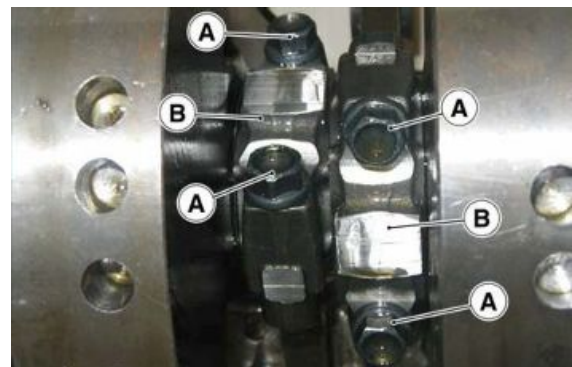

See also

[Removing the flywheel](#)
[Disassembling the piston](#)
[Removing the cylinder](#)
[Removing the cylinder head](#)

Inspecting the crankshaft components

Check the surfaces of the main journals; if they are scored or oval-shaped, reface them (observing the undersize charts), and replace the flanges and the main journals.

FITTING CLEARANCES

Specification	Desc./Quantity
Between the bearing and the main journal on the timing system side	0.028 ÷ 0.060 mm (0.00110 ÷ 0.00236 in);
Between the bearing and the main journal on the flywheel side	0.040 ÷ 0.075 mm (0.00157 ÷ 0.00295 in)
Between the bearing and the connecting rod pin	0.022 ÷ 0.064 mm (0.00087 ÷ 0.00252 in)

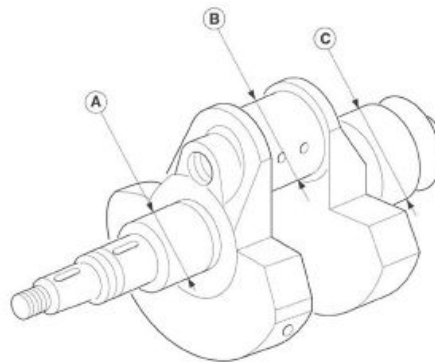

MAIN JOURNAL DIAMETER ON THE TIMING SYSTEM SIDE (A)

Specification	Desc./Quantity
Main journal regular production	37.975 mm (1.49507 inch) 37.959 mm (1.49444 inch)

CRANKPIN DIAMETER (B)

Specification	Desc./Quantity
Regular production	44.008 ÷ 44.020 mm - (1.73259 ÷ 1.73307 in)
'Blue' bushing half-shell regular production	44.008 ÷ 44.014 mm (1.73259 ÷ 1.73283 in)
'Red' bushing half-shell regular production	44.014 ÷ 44.020 mm (1.73283 ÷ 1.73307 in)

FLYWHEEL SIDE MAIN JOURNAL DIAMETER (C)

Specification	Desc./Quantity
Regular production	52.970 mm (2.08542 inch) 53.951 mm (2.12405 inch)

Checking the connecting rod

CONNECTING RODS

When examining the connecting rods, check that:

- Bushings are in good conditions, their clearance and the pins;
- Shaft parallelism;
- Connecting rod bearings.

These are thin shell bearings, anti-friction alloy that does not allow for any adaptation; replace them immediately if seizing or wear marks are found.

Upon replacing the bearings it may be necessary to ream the crankshaft pin.

Before reaming the crankpin, measure the pin diameter comparing it with the maximum wear allowed, as indicated in the figure; this defines what kind of undersizing the bearing should have and to which diameter the pin should be reamed.

Checking shaft parallelism

Check shafts for squaring before fitting them.

It is therefore necessary to check that the head holes and the rod small end are parallel and on the same plane.

The maximum parallelism and plane error of the two shafts of the head and rod small end, measured at 200 mm (7.873 inch) should be +/- 0.10 mm (0.00393 inch).

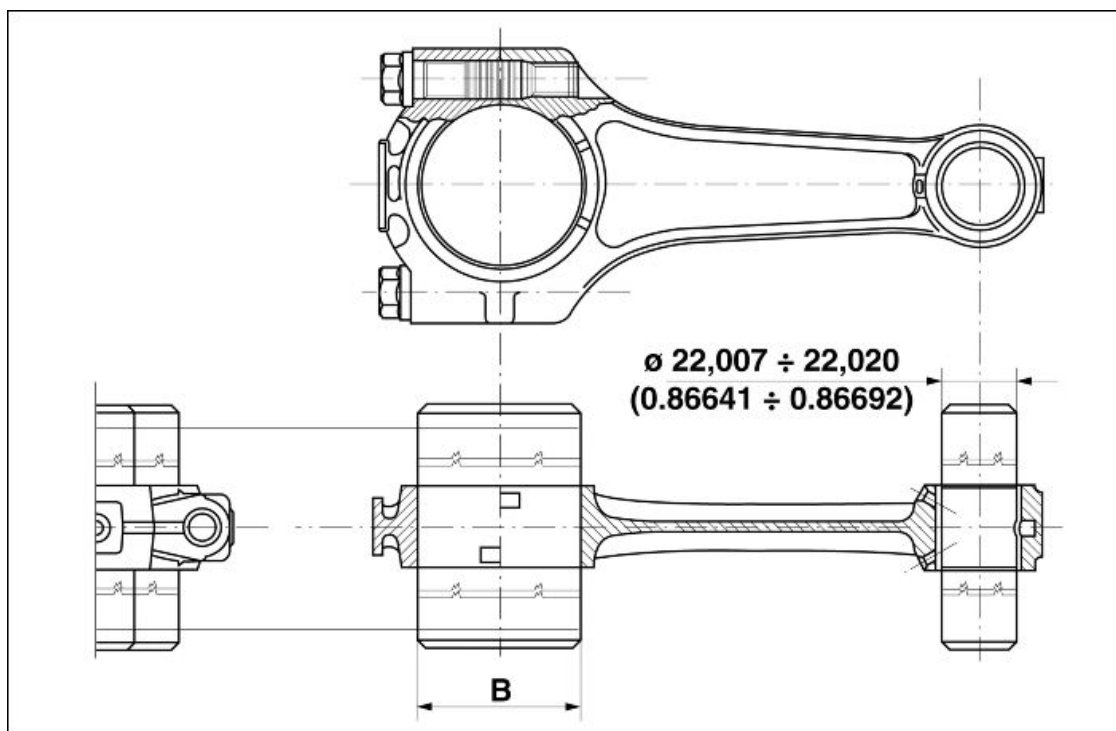

CONNECTING ROD BEARING THICKNESS

Specification	Desc./Quantity
Connecting rod bearing regular (production)	1.535 - 1.544 mm (0.06043 - 0.06079 in)
Regular 'Blue' connecting rod bearing (production)	1.539 - 1.544 mm (0.06059 - 0.06079 in)
Regular 'Red' connecting rod bearing (production)	1.535 - 1.540 mm (0.06043 - 0.06063 in)

CRANKPIN DIAMETER (B)

Specification	Desc./Quantity
Regular production	44.008 ÷ 44.020 mm - (1.73259 ÷ 1.73307 in)
'Blue' bushing half-shell regular production	44.008 ÷ 44.014 mm (1.73259 ÷ 1.73283 in)
'Red' bushing half-shell regular production	44.014 ÷ 44.020 mm (1.73283 ÷ 1.73307 in)

PIN-BUSHING COUPLING DATA

Specification	Desc./Quantity
fitted and machined bushing inside \varnothing mm (inch)	22.007 mm (0.86641 inch) - 22.020 mm (0.86692 inch)
pin \varnothing mm (inch)	21.994 mm (0.86590 inch) - 21.998 mm (0.86606 inch)
Clearance between pin and bushing mm (inch)	0.009 ÷ 0.026 mm (0.000354 ÷ 0.001024 inch)

Assembling the connecting rod

- The references on the connecting rods should be facing the flywheel.
- Do not interchange left and right connecting rods.



- Place the connecting rods and the caps (B) on the crankshaft and fasten them with new screws (A).
- Remember these recommendations:

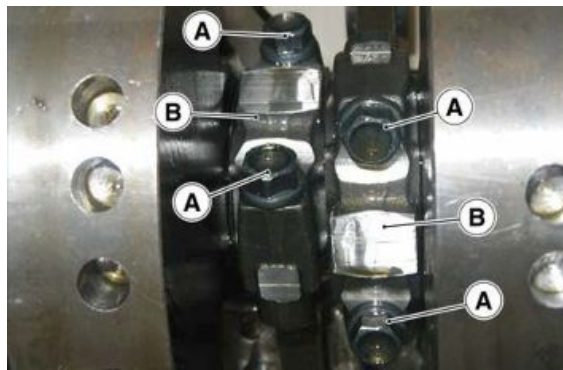

- The screws fixing the connecting rods to the crankshaft must be replaced with new ones at the following refitting as they are subject to high loads and stress;
- The fitting clearance between bearing and connecting rod pin is 0.028 mm (0.0011 inch) minimum and 0.052 mm (0.0020 inch) maximum;
- The clearance between the shim washers of the connecting rod and those of the crankshaft is comprised between 0.30 mm (0.01181 in) and 0.50 mm (0.01968 in);
- Lock the screws (A) on the caps (B) with a torque wrench at the prescribed torque.

Installing the crankshaft

- Use the sealing ring fitting tool on the flywheel-side flange to fit the sealing ring on the flange.

Specific tooling

19.92.71.00 Tool to fit the seal ring on the flywheel-side flange

- Fit a new gasket between the crankcase and the crankshaft flange, flywheel side.

- Introduce the crankshaft.
- Place the flywheel side crankshaft support flange, taking into account the fitting order indicated by the holes.

Specific tooling

19.92.71.00 Tool to fit the seal ring on the flywheel-side flange



- Apply Teflon tape on the two lower fixing screws at the back in order to prevent oil leaks.
- Screw the eight flange screws on the flywheel side proceeding diagonally.



Lubrication

Oil pump

Removing

- Drain all the engine oil.
- Remove the alternator.
- Remove the timing system.
- Remove the shim washer.



- Unscrew and remove the three screws fixing the oil pump.
- Remove the oil pump.



Installing

- Fit the oil pump.
- Tighten the three oil pump fixing screws.



- Place the shim washer adequately so that the timing chain do not wear out the crankcase.
- Fit the timing system.
- Fit the alternator.
- Top-up with engine oil.



Removing the oil sump

NOTE

TO REMOVE THE OIL SUMP, PLACE A SUITABLE CONTAINER UNDER IT TO COLLECT THE USED OIL AND DRAIN OUT ALL OIL.

CAUTION

THE NEW LUBRICATION SYSTEM IS VALID FROM ENGINE NUMBER N° KP15051 ON.

- If necessary, the filter can be removed with the suitable special tool.

Specific tooling

01.92.91.00 Wrench for removing the cover on sump and filter

- Unscrew and remove the oil level plug and collect the O-Ring.



- Undo and remove the fourteen screws fixing the oil sump to the engine crankcase.



- Unscrew and remove the four screws and remove the engine oil sump cover.



- Unscrew and remove the two screws.

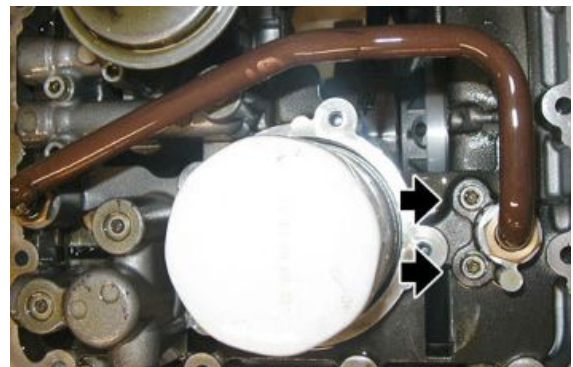

- Unscrew and remove the two screws.
- Remove the mesh filter and collect the gasket.

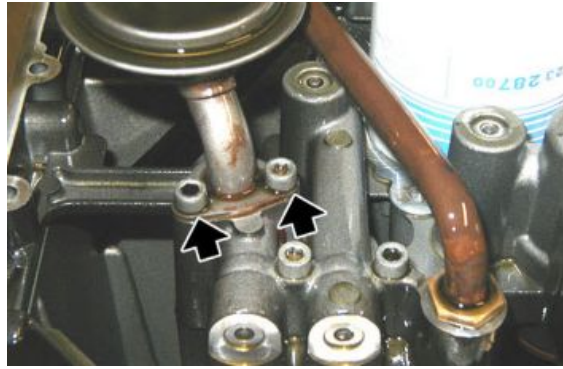

- Remove the black flange and collect the gasket.



- Unscrew and remove the plug.



- Remove the thermostatic valve.



- Unscrew and remove the pressure relief valve plug.
- Remove the pressure relief valve components

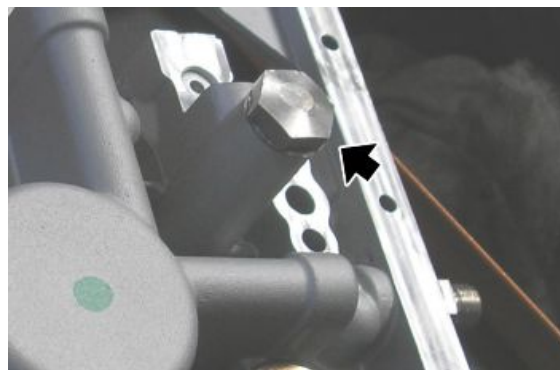

Refitting the oil sump

- Place the pressure relief valve components correctly.
- Screw the pressure relief valve plug.

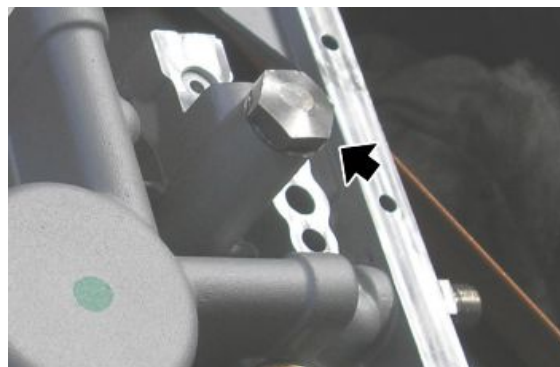

- In case of overpressure, the engine oil goes back into the oil sump through the hole indicated in the picture.



- Place the thermostatic valve.



CHECK THAT THE ENGINE OIL PASSAGE HOLE IS NOT CLOGGED.

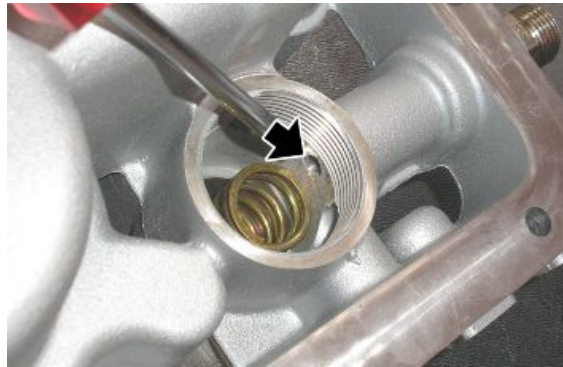

- Tighten the thermostatic valve plug.



- Place a new gasket and refit the black flange.



- Place a new gasket and refit the mesh filter tightening the two screws.

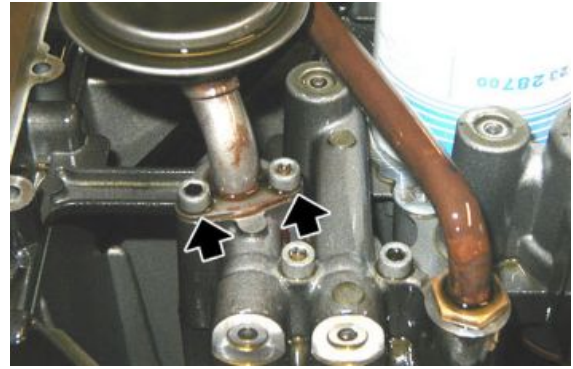

- Tighten the two screws.

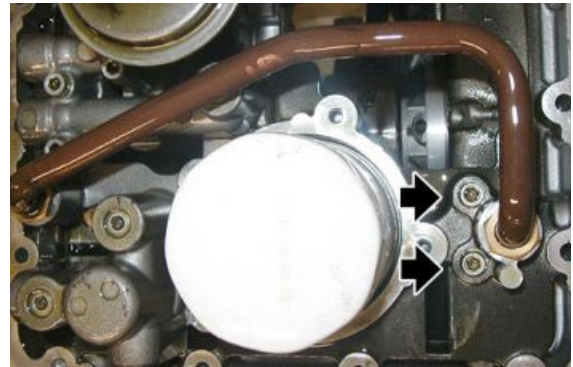

- Place the oil sump cover.
- Tighten the four screws.
- Refit the oil sump on the base.
- Fill engine oil up to the correct level.



Blow-by

- Loosen the oil return pipe sealing joint and remove the oil return pipe from the crankcase.



- Remove the clamp.



- Release the two straps retaining the oil breather pipe.



- Remove the two oil breather pipes.



- Unscrew and remove the oil return pipe positioning screw.
- Release the oil return pipe



- Remove the complete blow-by system.



INDEX OF TOPICS

POWER SUPPLY

P SUPP

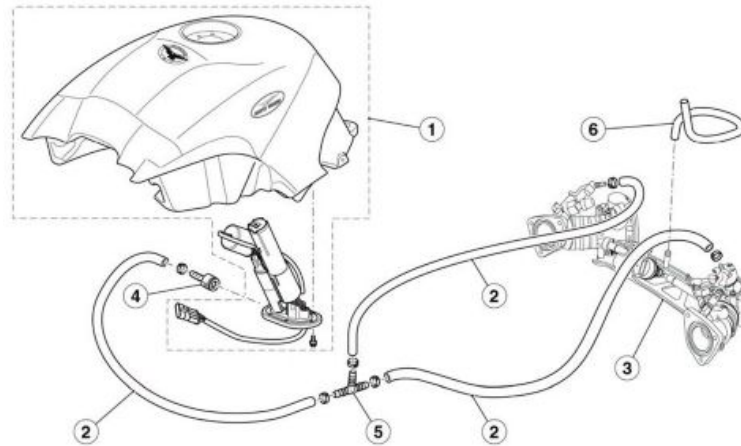
Circuit diagram**Key:**

1. Full fuel tank
2. Fuel pipe
3. Throttle body
4. Joint
5. Three-way joint
6. Pipe

Injection

Diagram

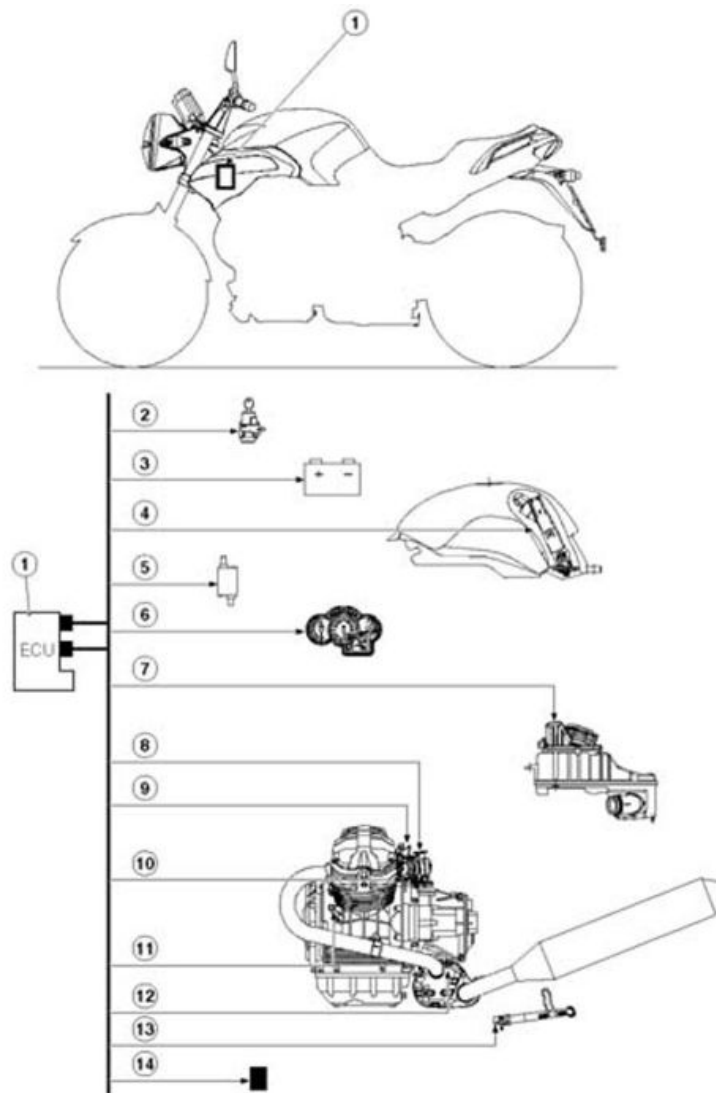
**Key:**

1. Control unit
2. Ignition switch
3. Battery
4. Fuel pump
5. Coils
6. Instrument panel
7. Air temperature sensor
8. Throttle valve position sensor
9. Injectors
10. Engine temperature sensor
11. Crankshaft position sensor
12. Lambda probe

13. Side stand

14. Fall sensor

Cylinders synchronisation

- With engine off, connect the Navigator tool to the diagnosis connector and to the vehicle battery.



- Turn on the scanner.
- Screw the joints connecting the vacuum pipes on the inlet pipe holes.
- Connect the vacuum pipes to the relative joints.
- Set the key to ON.
- Make sure there are no errors in the control unit; otherwise, solve them and repeat the procedure.

- Make sure the left throttle is fully in.



DO NOT TOUCH THE THROTTLE ABUTMENT SCREW OR THE THROTTLE BODY MUST BE REPLACED. CHECK THAT THE THROTTLE RETURN CABLE IS NOT TAUT.



- The Axone should display the adjustable parameters screen page.
- Autodetect the throttle position.

- Turn the key to "OFF" and leave it for at least 30 seconds.
- Turn the key back to "ON" and restore the Axone session.
- Check that the "Throttle" value reading is $4.7 \pm 0.2^\circ$. If the value is incorrect, replace the control unit and repeat the procedure from the start.
- Completely close the two by-pass screws on the throttle bodies.
- Start the engine.
- Take the engine to the prescribe temperature: 60°C (140°F).
- Make the engine rev at 2000/3000 rpm and with the vacuumometer check that the difference between the two pressures is 1 cm Hg (1.33 kPa) maximum.

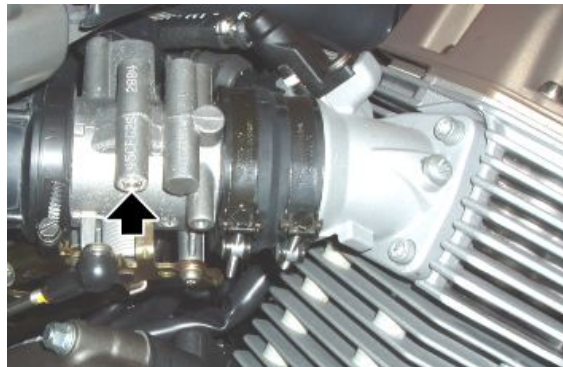
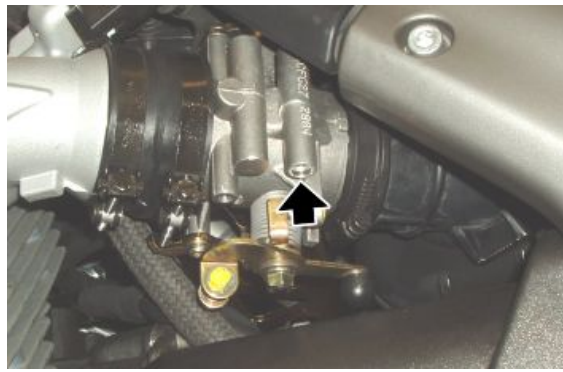

If this condition is detected:

- take the engine back to idle and check the depression values so that they are aligned between the two cylinders. Otherwise, open only the screw with higher depression, using the by-pass screws, to compensate.

If there is a larger difference:

- act on the set screw of the throttle body connecting rod to reduce the pressure difference in the two pipes.
- Repeat the procedure "Throttle position self-acquisition" as explained above.
- Take the engine back to idle and check the depression values so that they are aligned between the two cylinders.
- Otherwise, open only the screw with higher depression, using the by-pass screws, to compensate.

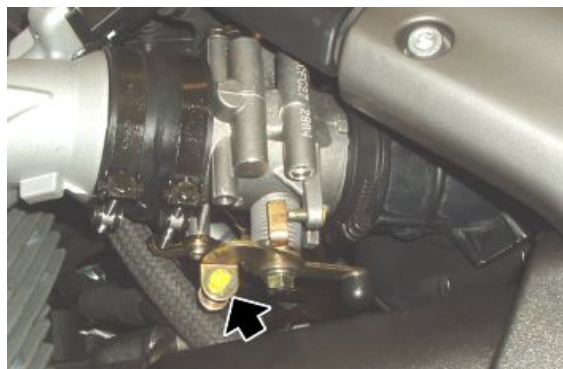

Recovery function

If the signal of the following sensors is interrupted, the control unit determines some values to keep the engine running or it uses a different parameter. The instrument panel and the Axone also signal the problem.

RECOVERY FUNCTION

Specification	Desc./Quantity
air temperature	25 °C (77 °F)
engine temperature	30 °C (86 °F)
	with linear increase from the air temperature at ignition
barometric pressure	1010 hPa
throttle valve potentiometer	2.9° at idle, otherwise variable.
idle motor	fixed value variable depending on the vehicle

Using axone for injection system

Injection

Iso screen page

ISO

This screen page shows general data regarding the control unit, for example software type, mapping, control unit programming date



ISO DISPLAY

Specification	Desc./Quantity
Mapping	-

Engine parameter reading screen page

ENGINE PARAMETER READING

This screen page shows the parameters measured by the several sensors (engine revs, engine temperature, etc.) or values set by the control unit (injection time, ignition advance, etc.)

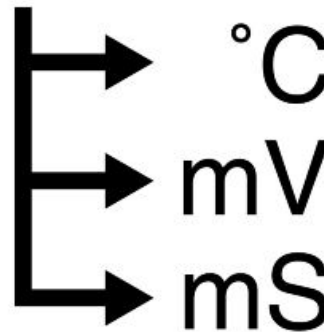

ENGINE PARAMETER READING SCREEN PAGE

Specification	Desc./Quantity
Engine rpm	Engine revolutions per minute: the minimum value is set by the control unit cannot be adjusted
Injection time	- ms
Ignition advance	- °
Air temperature	°C Temperature of the air taken in by the engine, measured by the sensor in the filter casing. This is not the temperature indicated by the instrument panel
Engine temperature	°C
Battery voltage	V
Throttle	Value corresponding to the throttle when closed (approximate value between 4.5 and 4.9°) (left throttle supported by the end of stroke screw). If a different value is read, it is necessary to activate the parameter "Throttle positioner autodetection" and obtain this value.
Atmospheric pressure	1015 mPa (approximate values) The sensor is inside the instrument panel
Lambda probe	100 - 900 mV (approximate values) Signal when energised that the control unit receives from the lambda probe: inversely proportional to the presence of oxygen
Lambda integrator	When the control unit uses the lambda probe signal (see the 'Lambda' parameter on the 'Device status' display) this value should be close to 0%
Vehicle speed	- km/h
Target engine revs	1150 rpm (approximate values) Parameter valid at idle, setting depends especially on the engine temperature: the control unit will try to keep the engine running at this revs, acting on the ignition advance and the Stepper motor
Stepper base	70 - 100 (approximate values) Steps corresponding to the Stepper motor reference position
CL Stepper	70 - 150 (approximate values) Steps set by the control unit for the Stepper motor. At idle, steps so that the engine keeps the target engine revs set by the control unit
Stepper regulator	Difference between current steps of motor at idle and those at the reference position
Virtual throttle angle from Stepper	0° With engine not at idle speed, this value indicates the throttle degrees corresponding to the Stepper motor air flow

Device status screen page

DEVICE STATUS

This screen page shows the status (usually ON/OFF) of the vehicle devices or the operation condition of some vehicle systems (for example, lambda probe functioning status).

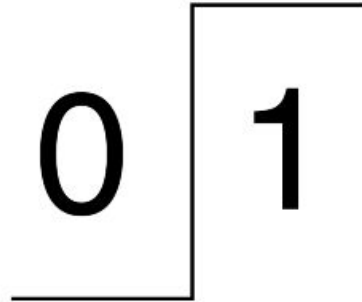

DEVICE STATUS

Specification	Desc./Quantity
Engine status	ON/run/power-latch/stopped operation conditions
Throttle position	Released / pressed indicates if the throttle potentiometer is open or closed
Stand	Retracted / extended indicates the position of the side stand (only with gear engaged)
Ignition	Enabled / disabled indicates if the control unit consents engine start-up
RUN / STOP switch	Run / stop indicates the position of the safety switch
Clutch	No / Yes indicates the clutch sensor status
Gear engaged	No / Yes indicates the gear sensor status
fall sensor	Normal / Tip over indicates the vehicle fall sensor status
Lambda	Open loop / Closed loop Indicates if the control unit is using (CLOSED) the lambda probe signal to keep the stoichiometric combustion. At idle CLOSED only if: Air T over 20°C (68°F) and engine T over 30°C (86°F) and engine on for at least 2-3 minutes
Synchronisation	Synchronised / Not synchronised Indicates if the control unit detects the revolution sensor signal correctly

Devices activation screen page

DEVICES ACTIVATION

This screen page is used to delete errors in the control unit memory and to activate some systems controlled by the control unit.



DEVICES ACTIVATION

Specification	Desc./Quantity
Left coil	operation for 2.5 m, 5 times

Specification	Desc./Quantity
Right coil	operation for 2.5 m, 5 times
Left injector	Operation for 4 m, 5 times
Right injector	Operation for 4 m, 5 times
Error clearing	By pressing the 'enter' button, the stored errors (MEM) become part of the historical data (STO). In the next connection between the Navigator and the control unit, the historical errors (STO) are no longer shown
Fuel pump	Operation for 30"
Stepper control	For 4" advancement command of 32 steps, for the next 4" retrocession command of 32 steps and so on for 30"

Errors display screen page

ERRORS DISPLAY

This screen page shows potential errors detected in the vehicle (ATT) or stored in the control unit (MEM) and it allows to check error clearing (STO).



ERRORS DISPLAY

Specification	Desc./Quantity
Pressure sensor	Possible short circuit in the earth lead, battery or open circuit: recovery function noticeable for customer. Careful with the air pressure sensor in the instrument panel
Air temperature	Possible short circuit in the earth lead, battery or open circuit: recovery function hardly noticeable for customer.
Engine temperature	Possible short circuit in the earth lead, battery or open circuit: recovery function.
Throttle actuator position sensor	Possible short circuit in the earth lead, battery or open circuit: recovery function noticeable for customer.
Lambda probe	Possible short circuit on the earth lead, battery or open circuit or plausibility: recovery function hardly noticeable for customer.
Left injector	Possible short circuit in the earth lead, battery or open circuit. If both injectors do not work, the engine does not work
Right injector	Possible short circuit in the earth lead, battery or open circuit. If both injectors do not work, the engine does not work
Fuel pump relay	Possible short circuit in the earth lead, battery or open circuit: the engine does not start.
Left coil	Possible short circuit in the earth lead, battery or open circuit. If both coils do not work, the engine does not work.
Right coil	Possible short circuit in the earth lead, battery or open circuit. If both coils do not work, the engine does not work.
Idle regulator	Possible short circuit in the earth lead, battery or open circuit: recovery function noticeable for the customer due to no idle management
Battery voltage	Battery voltage detected is too low (7V) or too high (16V) for a certain period
Starter diagnosis	Possible short circuit in the earth lead, battery or open circuit.
Engine revolution sensor	Possible open circuit.
Lambda heater	Possible short circuit in the earth lead, battery or lambda probe heating circuit open.
SPEED SENSOR	

Specification	Desc./Quantity
CAN line diagnosis	Possible error on line CAN: short circuit or line break or no signal or plausibility error detected.
RAM memory	Possible internal control unit error. Also check the control unit supply and earth connections
ROM memory	Possible internal control unit error. Also check the control unit supply and earth connections
Microprocessor	Possible internal control unit error. Also check the control unit supply and earth connections
Checksum EPROM	Possible internal control unit error. Also check the control unit supply and earth connections

Adjustable parameters screen page

ADJUSTABLE PARAMETERS

This screen page is used to adjust some control unit parameters.

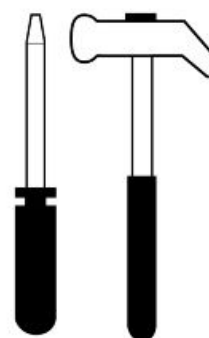

ADJUSTABLE PARAMETERS

Specification	Desc./Quantity
Throttle positioner autodetection	Allows the control unit to detect the closed throttle position: just press the enter button

INDEX OF TOPICS

SSUSPENSIONS

SUSP

Front

Front fork

Diagram

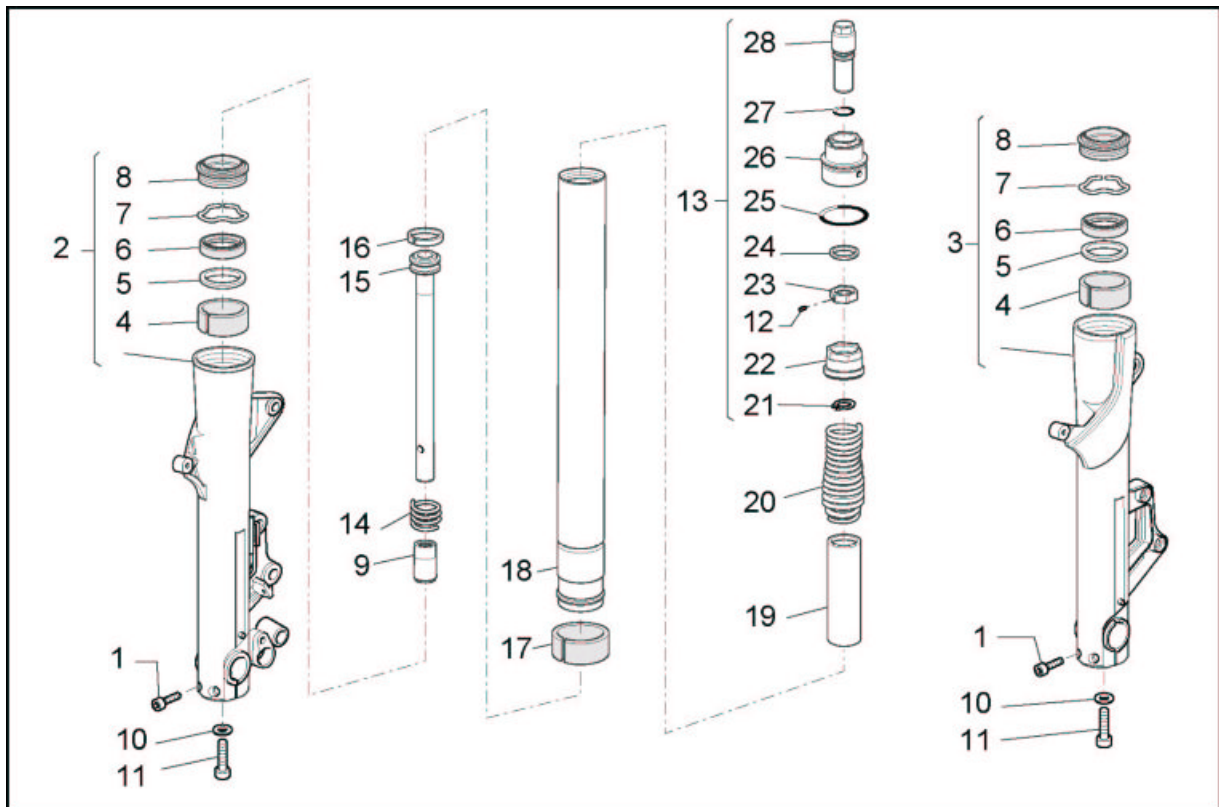
**KEY:**

1. Screw
2. Right sleeve
3. Left sleeve
4. Upper bushing
5. Cap
6. Sealing ring
7. Locking ring
8. Dust guard
9. Buffer
10. Washer
11. Screw
12. Pin
13. Complete cover
14. Counter spring

15. Complete pumping member
16. Ring
17. Lower bushing
18. Stem
19. Preload tube
20. Spring
21. Locking ring
22. Bushing
23. Nut
24. Fifth wheel
25. O-Ring
26. Cap body
27. O-Ring
28. Rigging pin

Removing the fork legs

- Unscrew the screws fixing the front mudguard and remove it.



- Unscrew the speed sensor screw, release the cable harness from the clamps.
- Remove the speed sensor.



- Unscrew the screws fixing the front brake callipers and remove them from their seat.



- Support the front part of the vehicle.
- Remove the nut fixing the wheel pin.
- Collect the sealing washer.



- Loosen the screws on the wheel pin terminals.



- Hit the wheel pin slightly with a rubber hammer so that the hole on the opposite side is exposed.

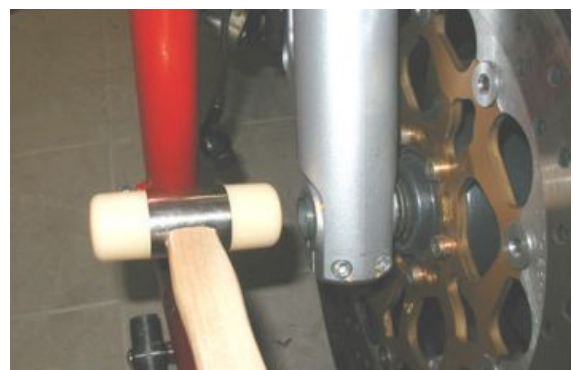

- Remove the wheel pin by inserting a screwdriver in the holes on the pin.



- During extraction, support the wheel and then remove it.

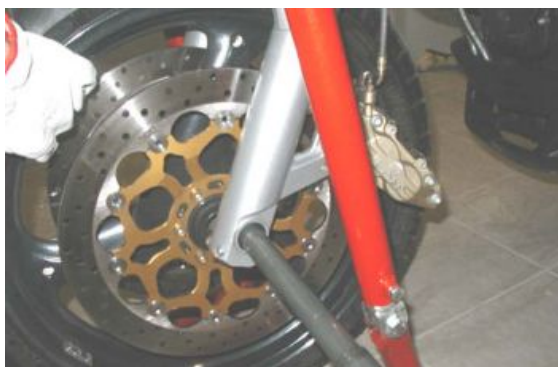

- Collect the spacer from the front wheel right side.



- Support the stanchion and loosen the screws on the upper and then the lower plate.





- Remove the fork stem.



Draining oil

To drain out the oil follow these operations:

- Remove the fork.
 - Unscrew the complete upper closing cap. Pay attention to the possible thrust that the spring can cause to the loosened cap.
 - Be careful not damage the O-Ring during extraction.
 - Press the stem inside the wheel holder sleeve.
 - Remove the spring.
-
- Be careful not damage the O-Ring during extraction.



- Press the stem inside the wheel holder sleeve.
- Remove the spring.



- Drain out all the oil inside the stem.
- Collect the preload tube.

**NOTE**

FOR EASY DRAINAGE OF THE OIL INSIDE THE PISTON ROD, PRESS THE STANCHION IN THE WHEEL HOLDER SLEEVE TO PUMP OIL OUT.



- Carefully check each part of the stem and make sure that there are no damaged elements.
- If there are no damaged or worn elements, refill the stem; otherwise, replace the damaged elements.

Disassembling the fork

- Drain out all the oil in the stem.
- Block the wheel holder sleeve with a vice.
- Unscrew the bottom screw and remove it together with its gasket.



- Remove the dust scraper using a screwdriver as a lever.

CAUTION

BE CAREFUL NOT TO DAMAGE THE SLEEVE RIM AND THE DUST SCRAPER.

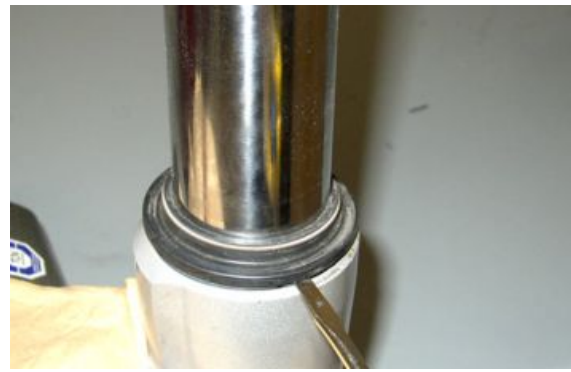

- Remove the locking ring inside the sleeve using a thin screwdriver.

CAUTION

BE CAREFUL NOT TO DAMAGE THE SLEEVE RIM.



- Slide off the stem from the wheel holder sleeve together with the lower bushing, sealing ring, cap, upper bushing and the entire pumping member.

NOTE

WHEN REMOVING THE STEM FROM THE WHEEL HOLDER SLEEVE SOME PARTS MAY REMAIN INSIDE THE SLEEVE. IF THIS OCCURS, THESE PARTS MUST BE REMOVED AFTERWARDS, BEING CAREFUL NOT TO DAMAGE THE SLEEVE RIM AND THE UPPER BUSHING SEAT



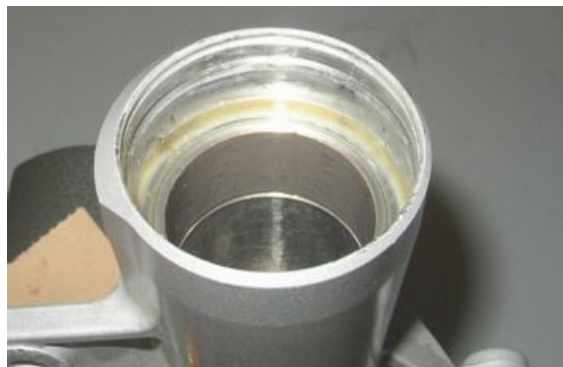

Checking the components

Stem

Check the sliding surface for scorings and/or scratches.

These scorings can be eliminated by rubbing them with wet sandpaper (grain 1).

If the scorings are deep, replace the stem.

Use a dial gauge to check that the stem bending is below the limit value.

If over the value, replace the stem.

CAUTION

A BENT STEM SHOULD NEVER BE STRAIGHTENED BECAUSE ITS STRUCTURE WOULD BE WEAKENED AND USING THE VEHICLE MAY BECOME DANGEROUS.

Characteristic

Bending limit:

0.2 mm (0.00787 in)

Sleeve

Check that there are no damages and/or cracks; otherwise, replace it.

Spring

Check the spring is in good conditions.

Check that the following components are in good conditions:

- upper bushing;



- lower bushing;
- piston.

If there are signs of excessive wear or damage, replace the affected component.

CAUTION

REMOVE ANY IMPURITY IN THE BUSHINGS, TAKING CARE NOT TO SCRATCH THEIR SURFACE.

Replace the following components with new ones:

- seal ring;



- dust gaiter;



- O-Ring on the cap.



Reassembling the fork

CAUTION

ALL COMPONENTS MUST BE CAREFULLY WASHED AND DRIED WITH COMPRESSED AIR BEFORE REFITTING.

- Carry out any necessary service operation.
- On the stem, fit the entire pumping unit together with counter spring and ring.



- Check that the upper guide bushing is fitted on the wheel holder fork leg.

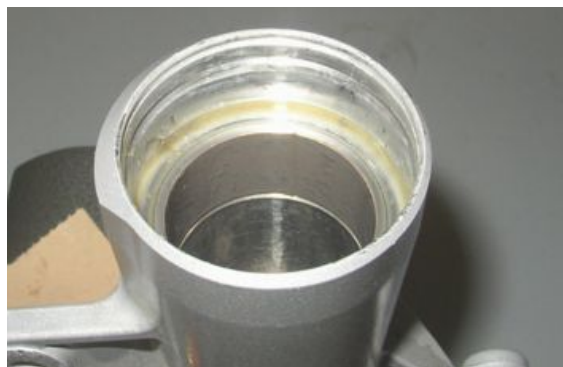

- Insert the lower sliding bushing in the seat on the stem.
- Refit the stem in the wheel holder fork leg pressing it until it stops.



- Screw the bottom screw and tighten it to the prescribed torque.



- Insert the cap and the well lubricated sealing ring in the stem.
- Use a suitable inserting tool to push the sealing ring in the fork leg until it stops.



- Fit the locking ring.



- Fit the dust scraper.



Filling oil

- Place the sleeve upright in a vice fitted with protection shoes.
- Compress the sleeve in the stem.
- Pour part of the fork oil into the sleeve.
- Wait some minutes until the oil fills all the ducts.
- Pour the remaining oil.
- Pump out oil a few times.
- Measure the air gap between the oil level and the rim.

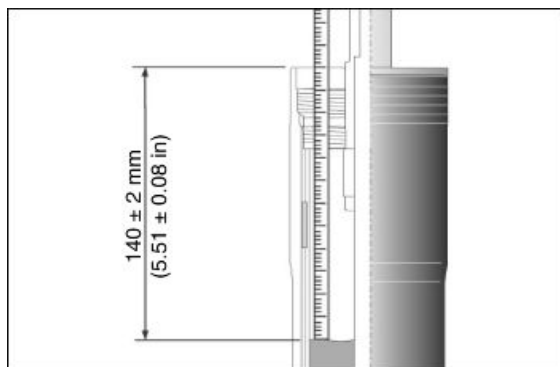

THE SLEEVE MUST BE PERFECTLY UPRIGHT IN ORDER TO MEASURE THE CORRECT OIL LEVEL. THE OIL LEVEL MUST BE THE SAME IN BOTH STANCHIONS.

Characteristic

Oil quantity (for each stem):

400 ± 2.5 cm³ (24.4 ± 0.15 cu in).

Oil level (from sleeve rim, without the spring and preloading pipe)

140 +/- 2 mm (5.51 +/- 0.08 in)

- Insert the preload tube and the spring.





- Place the cap on the bearing tube taking care not to damage the O-ring.



- Then, tighten the cap to the prescribed torque.



Installing the fork legs

- Insert the fork stem in position.



- Insert the wheel pin so that the stems are aligned.



- Tighten the screws on the fork plates to the prescribed torque.



- Remove the wheel pin
- Place the right side wheel with spacer.
- Insert the pin.

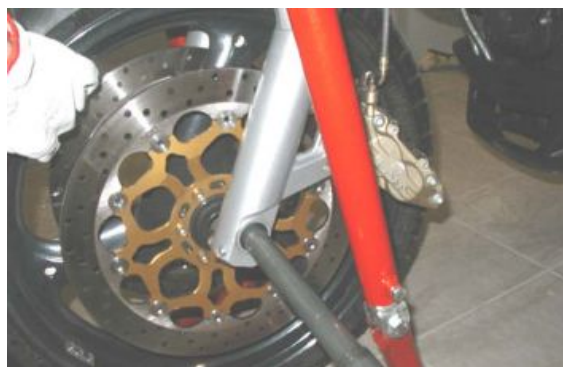

- Tighten the terminal screws (nut side) to lock the wheel pin



- Insert the sealing washer onto the wheel axle.
- Tighten the wheel axle fixing nut to the specified torque
- Make sure that the stanchions are aligned by working with the fork.



- Tighten the terminal screws that lock the wheel pin to the prescribed torque.



- Fit the brake callipers tightening the fixing screws to the prescribed torque.

CAUTION

AFTER FITTING THE BRAKE CALLIPERS, OPERATE THE FRONT BRAKE LEVER SEVERAL TIMES



- Fit the speed sensor.
- Tighten the speed sensor screw.
- Secure the speed sensor cable harness with clamps.



- Fit the front mud guard.



Steering bearing

Adjusting play

- Unscrew the upper bolt on the headstock.



- Operating on both half-handlebars, remove the lower fastening screw to the fork plate.



- Operating on both half-handlebars, remove the two upper fastening screws to the fork plate.
- Remove both half-handlebars but keep them connected to the cables.



- Operating from both sides, remove the fastening screw of the front cowl under the instrument panel.



- Lift the front cowl towards the instrument panel being careful not to force the hazard button and the temperature sensor cables.



- Remove the upper screw fastening the light holder fitting.



- Operating from both sides, remove the screw fastening the light holder fitting to the lower fork plate.



- Operating from both sides, remove the screw fixing the fork stems to the upper plate.



- Move the light holder fitting a few centimetres forward, together with the headlamp and instrument panel.



- Slide off the fork upper plate moving it towards the instrument panel.



- Rivet the safety washer on the headstock.

CAUTION

UPON REFITTING REPLACE THE SAFETY WASHER WITH A NEW ONE.



- Unscrew the upper ring nut.

CAUTION

UPON REFITTING TIGHTEN THE UPPER RING NUT MANUALLY AND THEN FORCE IT SLIGHTLY UNTIL THE NOTCHES ARE ALIGNED WITH THE RING NUTS.



- Remove the safety washer.



- Adjust the preloading of the steering bearings with the special tool.

NOTE

GET THE ADEQUATE SPECIAL TOOL.

Specific tooling

AP8140190 Tool for steering tightening



INDEX OF TOPICS

CHASSIS

CHAS

Swinging arm

Removing

- To remove the swingarm, first remove both footrest supporting plates and the exhaust silencer.
- Slide off the rear brake calliper from the disc and release the brake pipe.
- Remove the cover.



- Engage the first gear.
- Unscrew and remove the four screws, collecting the spacers and the dust protection ring.



- Unscrew and remove the fixing nut of the connecting rod assembly and collect the screw.



- Unscrew and remove the nut fixing the reaction rod.
- Remove the screw.
- Fix the reaction rod to the chassis with a clamp.



- Remove the clamp from the dust guard cap.



- Loosen the two swingarm terminal screws.



- Loosen the ring nut.

Specific tooling

GU14912603 Hook spanner for fixing ring nut of the clutch shaft internal body



- Helped by a second operator, remove the pin and remove the swingarm together with the cardan shaft.



Checking

- Check that the universal joint is not damaged, the gear teeth inserting in the sleeve grooves and the grooves on the joint are not deformed or damaged; otherwise, replace the joint.
- Check that the rubber bellows are not cut or pierced; otherwise, replace it.
- Check that the fork pin threads and the fork fixing nuts are not damaged, deformed or flattened; otherwise, replace them.
- Check that the sleeve grooves are not damaged, deformed or deteriorated; otherwise, replace the sleeve.
- Check that the sleeve outer tothing and grooves are not damaged.



Installing

- Spread a thin layer of lubricating grease all along the swingarm pin.
- Fit the ring nut in the swingarm pin and screw it manually.



- Working from both sides, grease the cardan shaft cables with the recommended product from the recommended products table.
- Block the swingarm, insert the universal joint, align the holes and, at the same time, helped by a second operator, insert the pin completely.
- Tighten the swingarm pin.



- Use the suitable box-spanner to tighten the ring nut.

Specific tooling

GU14912603 Hook spanner for fixing ring nut of the clutch shaft internal body



- Tighten the two screws of the swing-arm clamp.



- Fit the dust guard cap in the gearbox.
- Lock the dust guard cap with a new clamp.



- Place the reaction rod into its seat.
- Insert the screw.
- Screw the nut fixing the reaction rod.



- Place the connecting rod assembly on the swingarm.
- Insert the screw.
- Tighten the fixing nut of the connecting rod assembly.



- Place the dust-protection ring between the rim and the cardan shaft taking care to mount it with the collar facing the transmission unit.



- Place the rear wheel on the swingarm.
- Tighten the four screws with their spacers and the dust-protection ring.
- Place the cover.
- Place the rear brake calliper on the disc and the brake pipe on the swingarm.



Bevel gears

Removing

- To remove the gearbox, first remove the exhaust silencer and the rear wheel.



- Unscrew and remove the nut fixing the reaction rod.
- Remove the screw.
- Fasten the reaction rod to the chassis with a clamp.

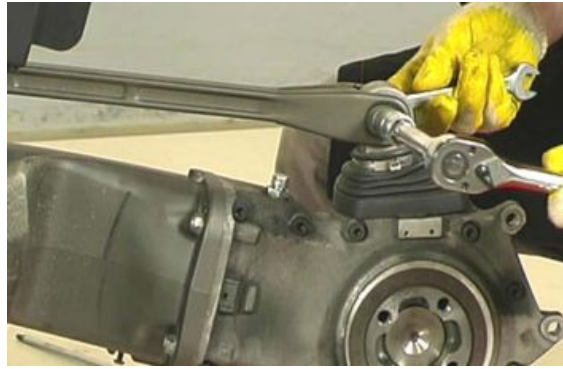

- Undo and remove the four screws.



- Remove the transmission casing sliding off the universal joint.



Checking

Casing unit fitting

Casing unit fitting

Assemble the dowel pins to the casing with the buffer and a hammer.



Assemble the casing to the special fastening tool.
Clean the casing faying surfaces carefully.

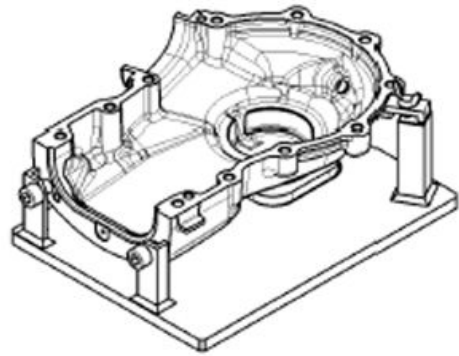

Heat the casing.



Insert the support group in the casing.



Assemble the cap and the ring.



Fit the cap on the support.
Fit the clamp.



Screw the clamp with the specific pliers.



Apply the prescribed sealant to the casing.



Fit a new sealing ring using the buffer.
Lubricate the sealing ring.



Assemble two centring stud bolts with M8 thread in the threaded holes of the casing as shown in the picture.



Fit the casing.
Remove the two dowel pins.



Assemble the fixing screws (7).
Tighten the screws (7) to the prescribed torque.
Remove excessive sealant.



Assemble the ring to the casing.



Tighten the fixing screws to the prescribed torque.



Fit the cap with the washer.

Screw the cap to the prescribed torque.



Fit the breather with the washer.

Screw the breather to the prescribed torque.

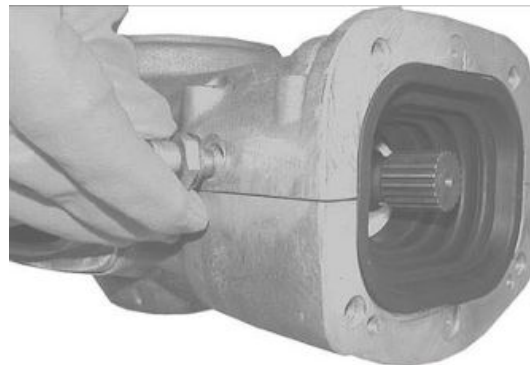

Fill the transmission with the prescribed oil.

Fit the cap with the washer.

Screw the cap to the prescribed torque.



Assemble the cap with the clamps.

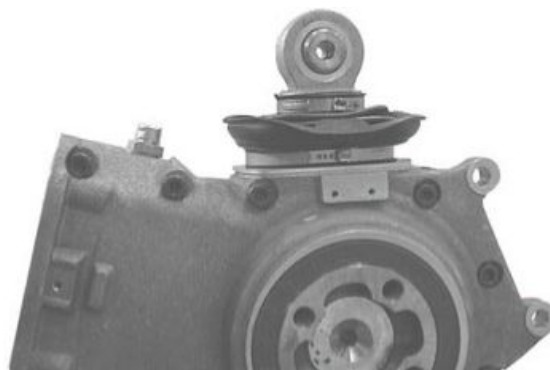

Fit the cap in its seat.



Wheel axle unit

Gruppo asse ruota

Removal

Remove the bearing from the wheel axle with a suitable extractor.



Turn the unit over.

Remove the bearing from the wheel axle with a suitable extractor.



FITTING

Heat the bearings to 100°C (212 °F).



Assemble the bearings to the wheel axle.



Turn the unit over.

Assemble the bearings to the wheel axle.

**Pinion unit****Pinion unit****Removal**

Remove the stop ring (1) from the ring nut.

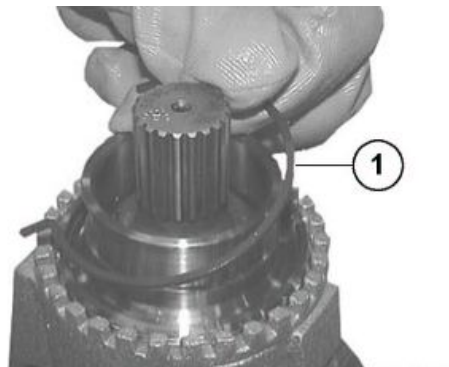

Unscrew the ring nut (2) with the special spanner (s4).

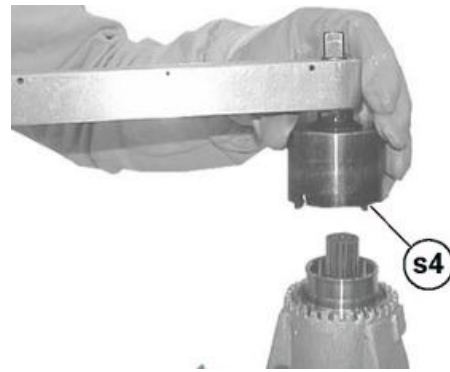

Remove the ring nut (2) and remove the sealing ring from the ring nut.

NOTE

THIS OPERATION DESTROYS THE SEALING RING.

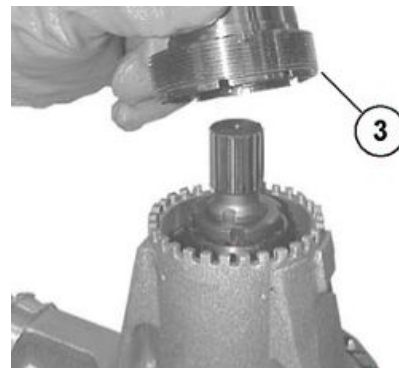

Assemble the sealing ring (3) to the ring nut (2) with the buffer CA715855 (see Fig.1) and a hammer.

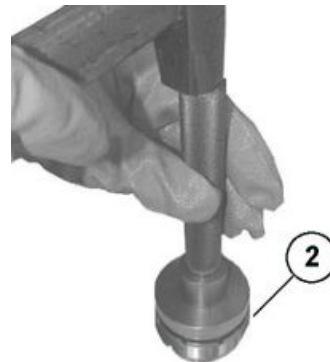

Lubricate the sealing ring (3).

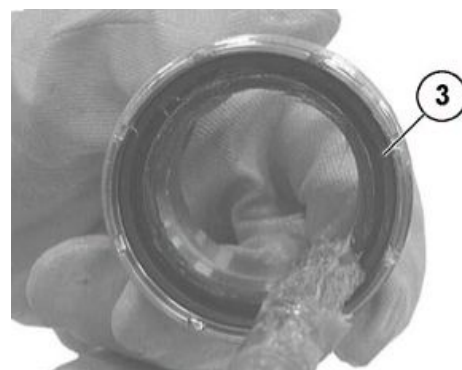

Assemble the ring nut (2).

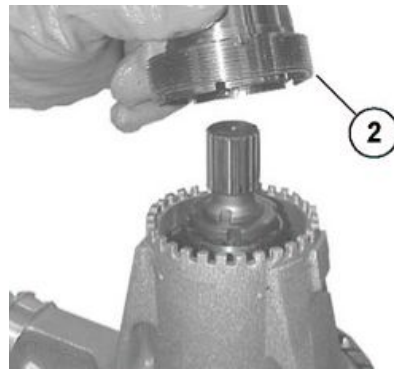

Tighten the ring nut (2) with the special spanner (s4) to the prescribe torque.

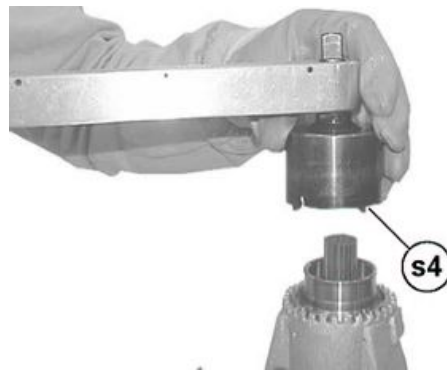

Insert the stop ring (1) in the ring nut (2) in the indicated direction.

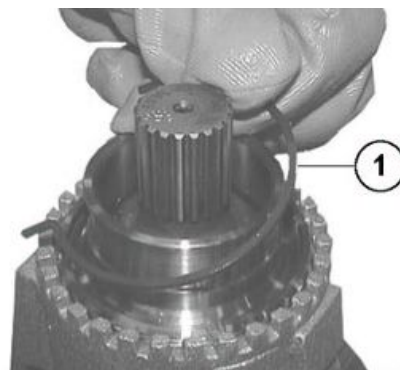

Assembly position of the stop ring (1).

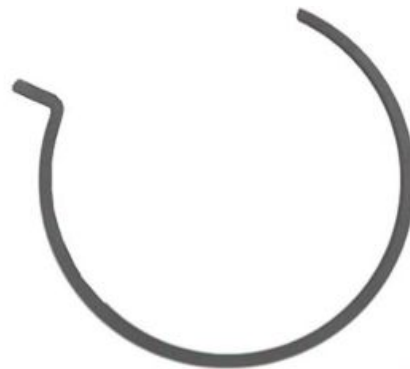

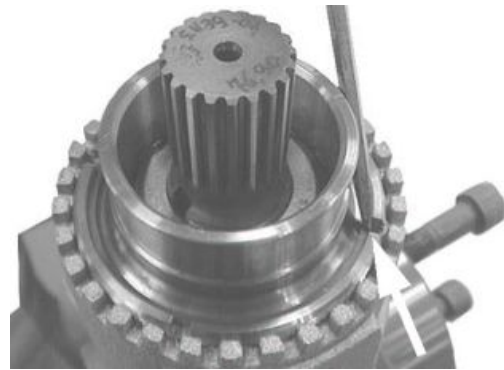
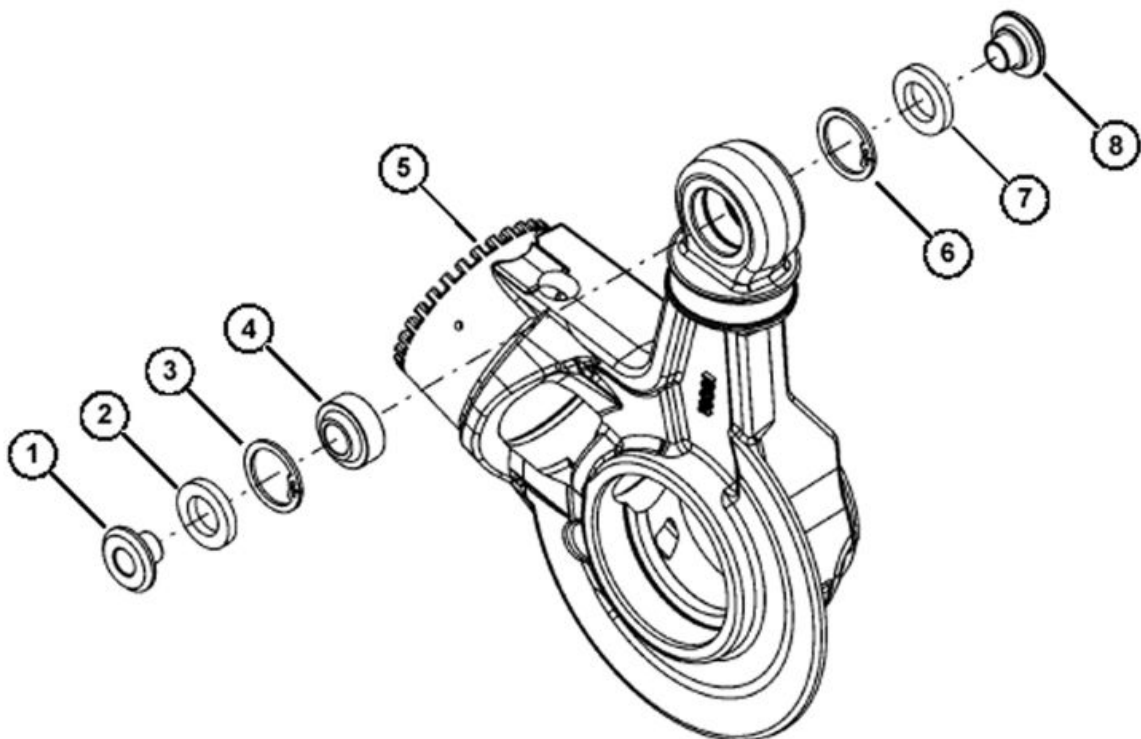
CAUTION**MAKE SURE THE STOP RING IS IN ITS SEAT.****Support unit****Support unit****Removal**

Remove the bushing (1) with a punch.

Turn the support (5) over and remove the other bushing (8).



Remove the sealing rings (2) and (7) with a screwdriver.

Remove the stop rings (3) and (6) from the support (5) with suitable pliers.

NOTE

THIS OPERATION DESTROYS THE SEALING RING.

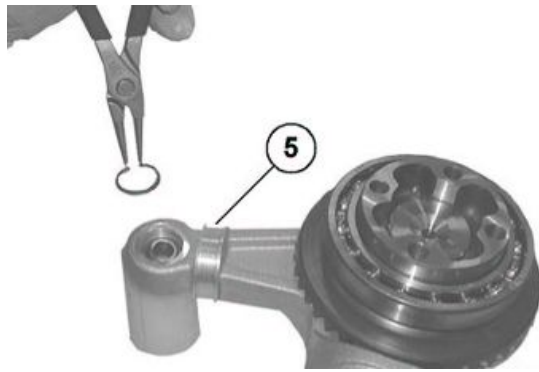

Remove the ball joint (4) with a suitable buffer and a rubber hammer.

**FITTING**

Fit the stop ring (6) in the support (5) with suitable pliers.

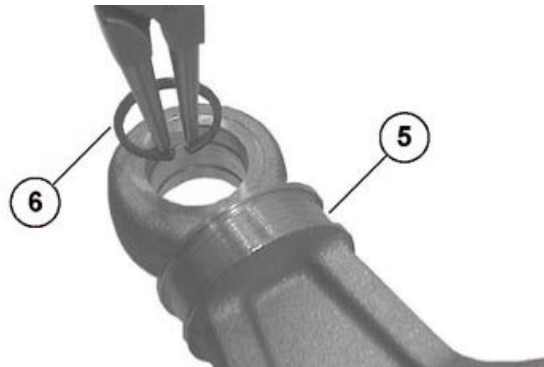

Turn the support (5) over.

Assemble the ball joint (4) with the buffer and a rubber hammer.

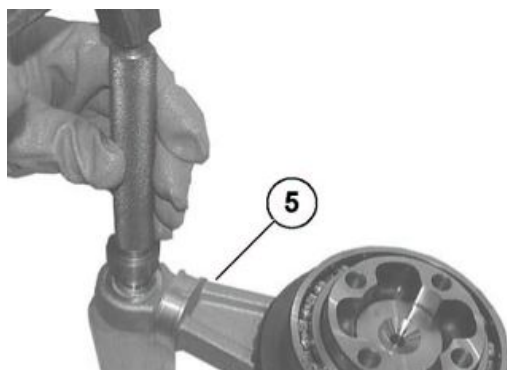

Fit the stop ring (3) in the support (5) with suitable pliers.

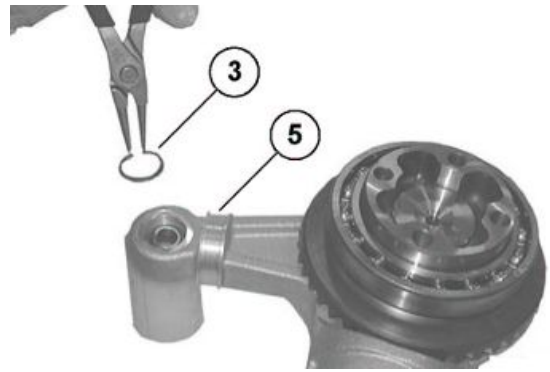

Manually assemble the new sealing rings (2) and (7).

Assemble the bushing (1).



Drive the bushing (1) in with a plastic hammer.

Turn the support (5) over and assemble the other bushing (8).



Casing unit removal

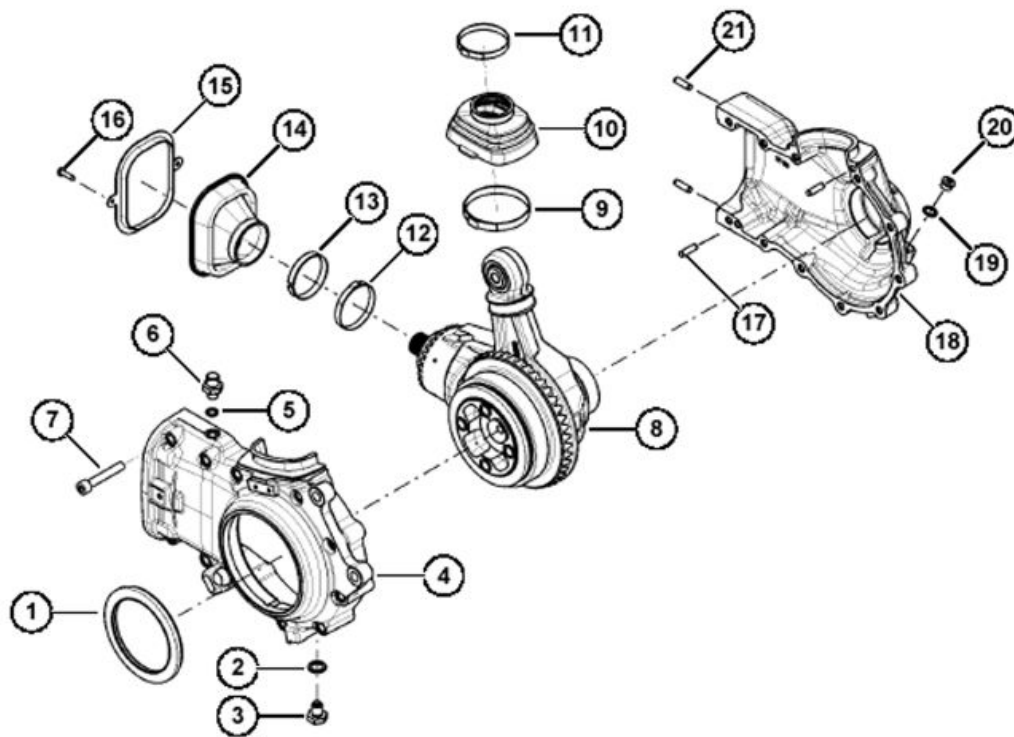

Casing unit removal

Remove the cover (20).

Remove the plug (3) to drain out the oil.



Lift the cap (10).



Remove the clamps (9) and (11).

Remove the cap (14).

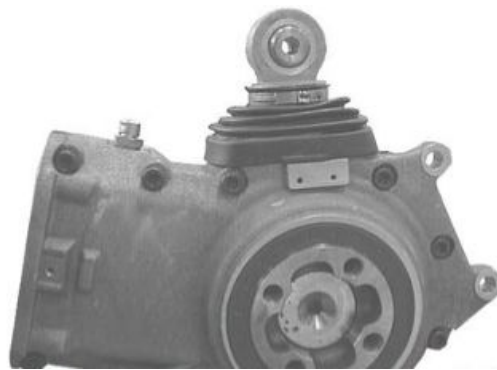

Remove the screws (16).



Collect the ring (15).



Remove the screws (7).

Remove the casing (4).

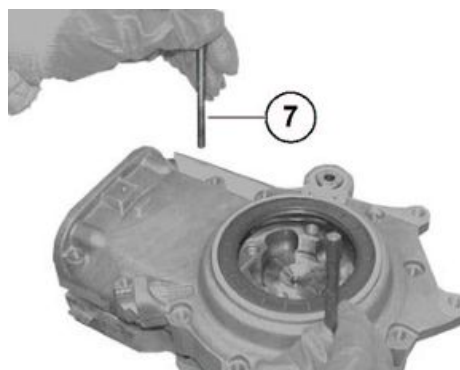

Remove the clamp (12).



Remove the cap (14).

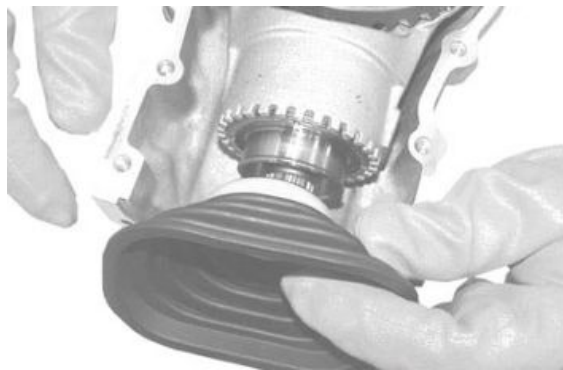

Collect the ring (13).



Remove the support unit (8).



TROUBLESHOOTING

Possible Cause	Operation
1. Fitting error of the radial seal or seal damaged 2. Sliding surface of the wheel axle seal spoiled or damaged	1. Replace the sealing ring and fit it correctly with the suitable tool 2. Replace the wheel axle

Possible Cause	Operation
1. Casing not sealed 2. Closing screws of the casing shells not tightened to the prescribed torque	1. Open the casing shells, clean the surfaces, seal and reassemble the casing shells 2. Tighten the closing screws to the correct torque
1. Dirt between the sealing ring and the casing 2. A used sealing ring has been fitted 3. Plug not tightened to the prescribed torque	1. Clean and tighten to the correct torque 2. Replace the sealing ring 3. Tighten the plug to the correct torque
1. Cap damaged 2. Retaining clamp or closing cover loose 3. Fitting error of the radial seal or seal damaged 4. Sliding surface of the wheel spacer spoiled or damaged	1. Replace the cap 2. Screw the clamp with suitable pliers 3. Replace the sealing ring and fit it correctly with the suitable tool 4. Replace the spacer
1. Cap damaged 2. Internal retaining clamp or external closing clamp loose	1. Replace the cap 2. Screw the internal or external clamp with suitable pliers
1. Bevel gear pair fitting error 2. Bevel gear pair toothing spoiled or damaged	1. Replace the bevel gear pair
1. Ball bearings on the wheel axle damaged	1. Replace the wheel bearings

Installing

- Insert the transmission casing on the swingarm making sure that the universal joint engages correctly.



- Tighten the four screws to the prescribed torque operating diagonally.



- Place the reaction rod into its seat.
- Insert the screw.
- Screw the nut fixing the reaction rod.



- Place the dust-protection ring between the rim and the cardan shaft taking care to mount it with the collar facing the transmission unit.



- Place the rear wheel on the swingarm.
- Tighten the four screws with their spacers and the dust-protection ring.
- Place the cover.
- Place the rear brake calliper on the disc and the brake pipe on the swingarm.



INDEX OF TOPICS

BRAKING SYSTEM

BRAK SYS

Front brake pads

Removal

- Turn the pins and remove both split pins.



- Remove both pins.



- Remove the vibration-damping plate.



- Extract one pad at a time.

CAUTION

AFTER REMOVING THE PADS, DO NOT OPERATE THE BRAKE LEVER OR THE CALLIPER PLUNGERS COULD GO OUT OF THEIR SEATS RESULTING IN BRAKE FLUID LEAKS.



Rear brake pads

Removal

- Undo and remove the two screws.
- Remove the brake calliper from the disc.
- Turn the pin and pull out the split pin.
- Remove the split pin.

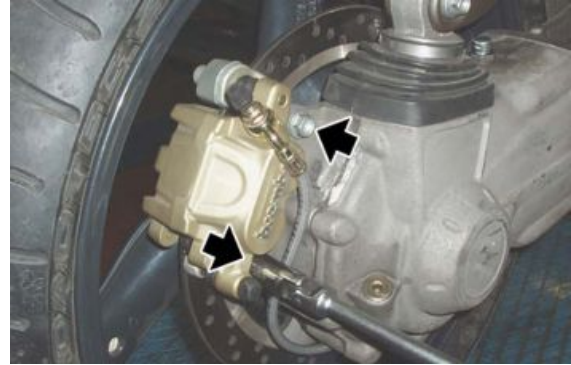

- Remove the pin.



- Extract one pad at a time.

CAUTION

AFTER REMOVING THE PADS, DO NOT OPERATE THE BRAKE LEVER OR THE CALLIPER PLUNGERS COULD GO OUT OF THEIR SEATS RESULTING IN BRAKE FLUID LEAKS.

- Insert two new pads, placing them so that the holes are aligned with the calliper holes.

CAUTION

ALWAYS REPLACE BOTH PADS AND MAKE SURE THEY ARE CORRECTLY POSITIONED INSIDE THE CALLIPER.

- Insert the pin.
- Place the split pin.
- Check the brake fluid level in the reservoir.



Bleeding the braking system

Front

Any air trapped in the hydraulic circuit acts as a cushion, absorbing much of the pressure applied by the brake pump and minimising the braking power of the calliper.

The presence of air is signalled by the "sponginess" of the brake control and poor braking efficiency.



CONSIDERING THE DANGER FOR VEHICLE AND RIDER, IT IS STRICTLY NECESSARY, AFTER REFITTING BRAKES AND RESTORING THE BREAKING SYSTEM TO THE REGULAR USE CONDITIONS, THAT THE HYDRAULIC CIRCUIT BE AIR PURGED.

NOTE

THE FOLLOWING OPERATIONS REFER TO ONLY ONE FRONT BRAKE CALLIPER BUT APPLY TO BOTH CALLIPERS. THE VEHICLE MUST BE ON LEVEL GROUND TO BE PURGED. WHILE PURGING THE HYDRAULIC SYSTEM, FILL THE RESERVOIR WITH THE NECESSARY QUANTITY OF BRAKE FLUID. CHECK THAT, DURING THE OPERATION, THERE IS ALWAYS BRAKE FLUID IN THE RESERVOIR.

- Remove the rubber protection cover from the bleed valve.
- Insert the transparent plastic pipe in the front brake calliper bleed valve and slide the other end of this pipe in a container to collect the fluid.
- Remove the front brake fluid reservoir cap.

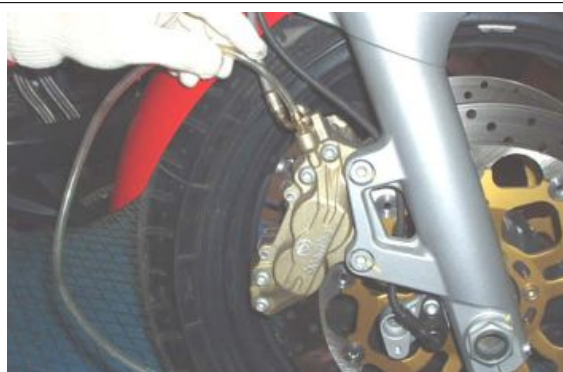

- Quickly press and release the front brake lever several times and then keep it fully pressed.
- Loosen the bleed valve 1/4 of a turn so that the brake fluid flows into the container. This will release the tension on the brake lever and will make it reach the end of stroke.
- Close the bleed valve before the lever reaches its end of stroke.
- Repeat the operation until the fluid draining into the container is air-bubble free.

NOTE

WHILE PURGING THE HYDRAULIC SYSTEM, FILL THE RESERVOIR WITH THE NECESSARY QUANTITY OF BRAKE FLUID. CHECK THAT, DURING THE OPERATION, THERE IS ALWAYS BRAKE FLUID IN THE RESERVOIR.

- Screw the bleeding valve and remove the pipe.
- Top-up the reservoir until the correct brake fluid level is obtained.
- Refit and block the front brake oil reservoir cap.
- Refit the rubber protection cover.

Any air trapped in the hydraulic circuit acts as a cushion, absorbing much of the pressure applied by the brake pump and minimising the braking power of the calliper.

The presence of air is signalled by the "sponginess" of the brake control and poor braking efficiency.



CONSIDERING THE DANGER FOR VEHICLE AND RIDER, IT IS STRICTLY NECESSARY, AFTER REFITTING BRAKES AND RESTORING THE BREAKING SYSTEM TO THE REGULAR USE CONDITIONS, THAT THE HYDRAULIC CIRCUIT BE AIR PURGED.

NOTE

THE FOLLOWING OPERATIONS REFER TO ONLY ONE FRONT BRAKE CALLIPER BUT APPLY TO BOTH CALLIPERS. THE VEHICLE MUST BE ON LEVEL GROUND TO BE PURGED. WHILE PURGING THE HYDRAULIC SYSTEM, FILL THE RESERVOIR WITH THE NECESSARY QUANTITY OF BRAKE FLUID. CHECK THAT, DURING THE OPERATION, THERE IS ALWAYS BRAKE FLUID IN THE RESERVOIR.



- Remove the rubber protection cover from the bleed valve.
- Insert the transparent plastic pipe in the front brake calliper bleed valve and slide the other end of this pipe in a container to collect the fluid.
- Remove the front brake fluid reservoir cap.
- Quickly press and release the front brake lever several times and then keep it fully pressed.
- Loosen the bleed valve 1/4 of a turn so that the brake fluid flows into the container. This will release the tension on the brake lever and will make it reach the end of stroke.
- Close the bleed valve before the lever reaches its end of stroke.
- Repeat the operation until the fluid draining into the container is air-bubble free.

**NOTE**

WHILE PURGING THE HYDRAULIC SYSTEM, FILL THE RESERVOIR WITH THE NECESSARY QUANTITY OF BRAKE FLUID. CHECK THAT, DURING THE OPERATION, THERE IS ALWAYS BRAKE FLUID IN THE RESERVOIR.

- Screw the bleeding valve and remove the pipe.
- Top-up the reservoir until the correct brake fluid level is obtained.
- Refit and block the front brake oil reservoir cap.
- Refit the rubber protection cover.

Rear

Any air trapped in the hydraulic circuit acts as a cushion, absorbing much of the pressure applied by the brake pump and minimising the braking power of the calliper.

The presence of air is signalled by the "sponginess" of the brake control and poor braking efficiency.

CAUTION

CONSIDERING THE DANGER FOR VEHICLE AND RIDER, IT IS STRICTLY NECESSARY, AFTER REFITTING BRAKES AND RESTORING THE BRAKING SYSTEM TO THE REGULAR USE CONDITIONS, THAT THE HYDRAULIC CIRCUIT BE AIR PURGED. THE VEHICLE MUST BE ON LEVEL GROUND TO BE PURGED. WHILE PURGING THE HYDRAULIC SYSTEM, FILL THE RESERVOIR WITH THE NECESSARY QUANTITY OF BRAKE FLUID. CHECK THAT, DURING THE OPERATION, THERE IS ALWAYS BRAKE FLUID IN THE RESERVOIR.

- Remove the rubber protection cover from the bleed valve.
- Insert the transparent plastic pipe in the rear brake calliper bleed valve and insert the other end of this pipe into a container to collect the fluid.
- Remove the rear brake fluid reservoir cap.
- Quickly press and release the rear brake lever several times and then keep it fully pressed.
- Loosen the bleed valve 1/4 of a turn so that the brake fluid flows into the container. This will release the tension on the brake lever and will make it reach the end of stroke.
- Close the bleed valve before the lever reaches its end of stroke.
- Repeat the operation until the fluid draining into the container is air-bubble free.

**NOTE**

WHILE PURGING THE HYDRAULIC SYSTEM, FILL THE RESERVOIR WITH THE NECESSARY QUANTITY OF BRAKE FLUID CHECK THAT, DURING THE OPERATION, THERE IS ALWAYS BRAKE FLUID IN THE RESERVOIR.

- Screw the bleed valve and remove the pipe.
- Top-up the reservoir until the right brake fluid level is obtained.
- Refit and lock the rear brake oil reservoir cap.
- Refit the rubber protection cover.

INDEX OF TOPICS

BODYWORK

BODYW

Air box

- Remove the fuel tank.
- Disconnect the connector from the air temperature sensor.



- Remove the oil breather pipe.



- Unscrew and remove the two screws from the oil vapour recovery reservoir.

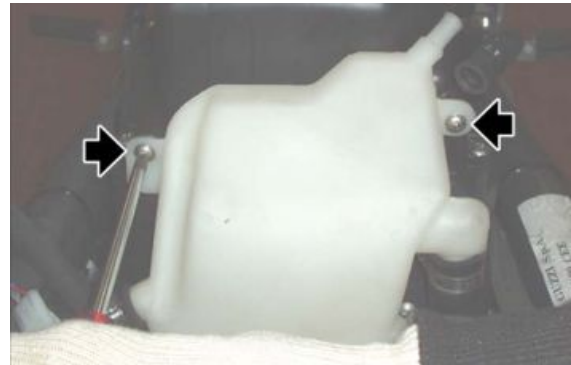

- Unscrew and remove the tube guide screw on the air filter casing.



- Move the oil vapour recovery reservoir aside.
- Unscrew and remove the two front screws from the air filter casing.

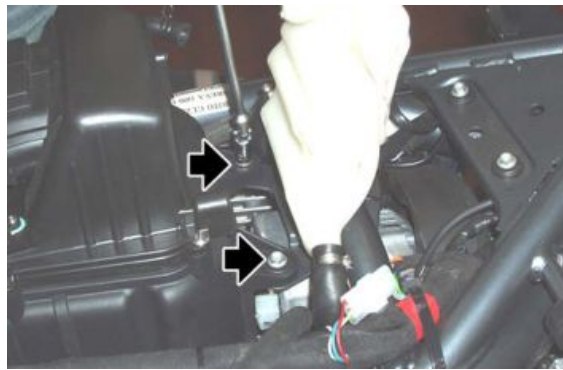

- Operating from both sides, loosen the clamp and slide off the sleeve from the throttle body.



- Lift the air filter casing and slide off the fuel depression pipe.
- Remove the air filter casing.

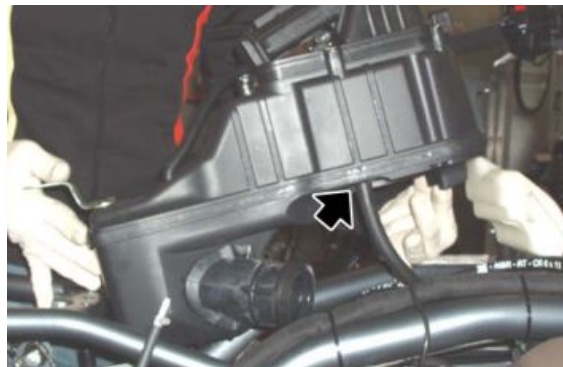

Fuel tank

- Remove the saddle.
- Working from both sides, undo and re-move the screw.

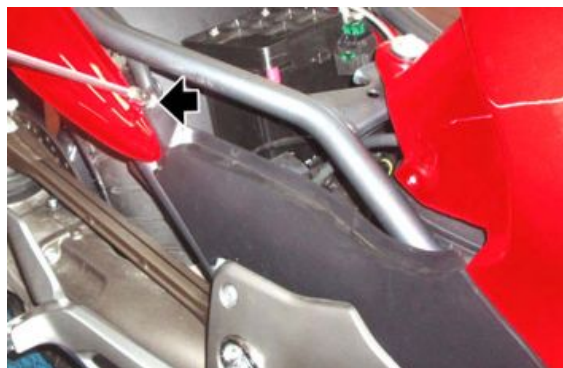

- Operating from both sides, lift the side fairing to remove it and slide it off the pin.



- Operating from both sides, unscrew and remove the two front screws.

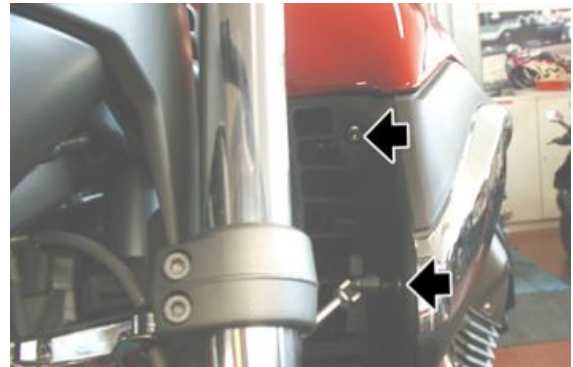

- Unscrew and remove the rear screw.



- Lift the fuel tank and remove the pipes from the "T" joint.



- Disconnect the connector.



- Disconnect the fuel pipe.



- Remove the fuel tank by sliding it off and back.



INDEX OF TOPICS

PRE-DELIVERY

PRE DE

Carry out the listed checks before delivering the motorcycle.

WARNING

HANDLE FUEL WITH CARE.

Aesthetic inspection

- Paintwork
 - Fitting of Plastic Parts
 - Scratches
 - Dirt
-

Tightening torques inspection

- Safety fasteners:
 - front and rear suspension unit
 - front and rear brake calliper retainer unit
 - front and rear wheel unit
 - engine - chassis retainers
 - steering assembly
 - Plastic parts fixing screws
-

Electrical system

- Main switch
 - Headlamps: high beam lights, low beam lights, tail lights (front and rear) and their warning lights
 - Headlight adjustment according to regulations in force
 - Front and rear stop light switches and their bulbs
 - Turn indicators and their warning lights
 - Instrument panel lights
 - Instrument panel: fuel and temperature indicator (if present)
 - Instrument panel warning lights
 - Horn
 - Electric starter
 - Engine stop via emergency stop switch and side stand
 - Helmet compartment electrical opening switch (if present)
-

-
- Through the diagnosis tool, check that the last mapping version is present in the control unit/s and, if required, program the control unit/s again: consult the technical service website to know about available upgrades and details regarding the operation.

CAUTION

TO ENSURE MAXIMUM PERFORMANCE, THE BATTERY MUST BE CHARGED BEFORE USE. INADEQUATE CHARGING OF THE BATTERY WITH A LOW LEVEL OF ELECTROLYTE BEFORE IT IS FIRST USED SHORTENS BATTERY LIFE.

CAUTION

UPON INSTALLING THE BATTERY, ATTACH THE POSITIVE LEAD FIRST AND THEN THE NEGATIVE ONE, AND PERFORM THE REVERSE OPERATION UPON REMOVAL.

WARNING

THE BATTERY ELECTROLYTE IS POISONOUS AS IT MAY CAUSE SERIOUS BURNS. IT CONTAINS SULPHURIC ACID. AVOID CONTACT WITH YOUR EYES, SKIN AND CLOTHING. IN CASE OF CONTACT WITH YOUR EYES OR SKIN, WASH WITH ABUNDANT WATER FOR APPROX. 15 MIN. AND SEEK MEDICAL ATTENTION IMMEDIATELY. IF ACCIDENTALLY SWALLOWED, IMMEDIATELY DRINK LARGE QUANTITIES OF WATER OR VEGETABLE OIL. SEEK MEDICAL ATTENTION IMMEDIATELY. BATTERIES PRODUCE EXPLOSIVE GASES; KEEP CLEAR OF NAKED FLAMES, SPARKS OR CIGARETTES. VENTILATE THE AREA WHEN RECHARGING INDOORS. ALWAYS WEAR EYE PROTECTION WHEN WORKING IN THE PROXIMITY OF BATTERIES. KEEP OUT OF THE REACH OF CHILDREN.

CAUTION

NEVER USE FUSES WITH A CAPACITY HIGHER THAN THE RECOMMENDED CAPACITY. USING A FUSE OF UNSUITABLE RATING MAY SERIOUSLY DAMAGE THE VEHICLE OR EVEN CAUSE A FIRE.

Levels check

- Hydraulic braking system fluid level
- Clutch system fluid level (if present)
- Gearbox oil level (if present)
- Transmission oil level (if present)
- Engine coolant level (if present)
- Engine oil level
- Mixer oil level (if present)

Road test

- Cold start
- Instrument panel operation

- Response to throttle control
 - Stability when accelerating and braking
 - Front and rear brake efficiency
 - Front and rear suspension efficiency
 - Abnormal noise
-

Static test

Static check after test drive:

- Restarting when warmed up
 - Starter operation (if present)
 - Minimum holding (turning the handlebar)
 - Uniform turning of the steering
 - Possible leaks
 - Radiator electric fan operation (if present)
-

Functional inspection

- Hydraulic braking system
- Stroke of brake and clutch levers (if present)
- Clutch - Check for correct operation
- Engine - Check for correct general operation and absence of abnormal noise
- Other
- Documentation check:
- Chassis and engine numbers check
- Supplied tools check
- License plate fitting
- Locks checking
- Tyre pressure check
- Installation of mirrors and any possible accessories



NEVER EXCEED THE RECOMMENDED INFLATION PRESSURES AS TYRES MAY BURST.

CAUTION



CHECK AND ADJUST TYRE PRESSURE WITH TYRES AT AMBIENT TEMPERATURE.

A

Air filter: 33

Air temperature sensor: 53, 55

B

Battery: 46, 51

Brake: 204, 205

Brake pads: 204, 205

C

Centre stand:

Chain: 118, 121–123

Clutch: 90, 93–95, 103, 105, 106

Coil: 54

Crankcase: 19, 136

Crankshaft: 19, 136, 138, 140

Cylinder: 18, 109, 111, 114, 129–133, 137

D

Desmodromic drum: 92

Display: 158

E

Electrical system: 12, 39, 40, 216

Engine oil: 30

Engine temperature sensor: 52

Exhaust:

F

Fairings:

Fork: 161, 162, 166, 170, 173

Forks: 92

Front wheel:

Fuel: 212

Fuel pump:

Fuses: 48

G

Gearbox oil: 32

H

Handlebar:

Head cover: 108, 112, 135, 136

I

Identification: 10

Instrument panel: 55

M

Maintenance: 8, 28

O

Oil filter: 32

Oil pressure sensor: 54

Oil sump: 142, 145

P

Primary shaft: 85, 91, 93

R

Rear wheel:

Recommended products: 20

S

Secondary shaft: 87, 92, 93

Side stand:

Speed sensor: 51

Stand:

Start-up: 47

Starter motor: 80, 102

T

Tank: 212

Transmission: 12, 29

Tyres: 14

W

Wiring diagram: 41