



MANUALE STAZIONE DI SERVIZIO

B043094



V7 Stone - V7 Special - V7 Racer



MANUALE STAZIONE DI SERVIZIO

V7 Stone - V7 Special - V7 Racer

THE VALUE OF SERVICE

As a result of continuous updates and specific technical training programmes for Moto Guzzi products, only **Moto Guzzi Official Network** mechanics know this vehicle fully and have the specific tools necessary to carry out maintenance and repair operations correctly.

The reliability of the vehicle also depends on its mechanical conditions. Checking the vehicle before riding it, its regular maintenance and the use of **original Moto Guzzi spare parts** only are essential factors!

For information on the nearest **Official Dealer and/or Service Centre** consult our website:

www.motoguzzi.com

Only by requesting Moto Guzzi original spare parts can you be sure of purchasing products that were developed and tested during the actual vehicle design stage. All Moto Guzzi original spare parts undergo quality control procedures to guarantee reliability and durability.

The descriptions and images in this publication are given for illustrative purposes only and are not binding. While the basic characteristics as described and illustrated in this booklet remain unchanged, Piaggio & C. S.p.A. reserves the right, at any time and without being required to update this publication beforehand, to make any changes to components, parts or accessories, which it considers necessary to improve the product or which are required for manufacturing or construction reasons.

Not all versions/models shown in this publication are available in all countries. The availability of individual versions/models should be confirmed with the official Moto Guzzi sales network.

The Moto Guzzi trademark is the property of Piaggio & C. S.p.A.

© Copyright 2012 - Piaggio & C. S.p.A. All rights reserved. Reproduction of this publication in whole or in part is prohibited.

Piaggio & C. S.p.A. Viale Rinaldo Piaggio, 25 - 56025 PONTEDERA (PI), Italy

www.piaggio.com

MANUALE STAZIONE DI SERVIZIO

V7 Stone - V7 Special - V7 Racer

Questo manuale fornisce le informazioni principali per le procedure di normale intervento sul veicolo. Questa pubblicazione è indirizzata ai **Concessionari Moto Guzzi** e ai loro meccanici qualificati; molte nozioni sono state volutamente omesse, perché giudicate superflue. Non essendo possibile includere nozioni meccaniche complete in questa pubblicazione, le persone che utilizzano questo manuale devono essere in possesso sia di una preparazione meccanica di base, che di una conoscenza minima sulle procedure inerenti ai sistemi di riparazione dei motoveicoli. Senza queste conoscenze, la riparazione o il controllo del veicolo potrebbe essere inefficiente o pericolosa. Non essendo descritte dettagliatamente tutte le procedure per la riparazione, e il controllo del veicolo, bisogna adottare particolare attenzione al fine di evitare danni ai componenti e alle persone. Per offrire al cliente maggiore soddisfazione dall'uso del veicolo, **Moto Guzzi** s.p.a. si impegna a migliorare continuamente i propri prodotti e la relativa documentazione. Le principali modifiche tecniche e modifiche alle procedure per le riparazioni del veicolo vengono comunicate a tutti i **Punti Vendita Moto Guzzi e alle Filiali nel Mondo**. Tali modifiche verranno apportate, nelle edizioni successive di questo manuale. Nel caso di necessità o dubbi sulle procedure di riparazione e di controllo, interpellare il **REPARTO ASSISTENZA Moto Guzzi**, il quale sarà in grado di fornirvi qualsiasi informazione al riguardo, oltre a fornire eventuali comunicazioni su aggiornamenti e modifiche tecniche applicate al veicolo.

NOTE Provides key information to make the procedure easier to understand and carry out.

CAUTION Refers to specific procedures to carry out for preventing damages to the vehicle.

WARNING Refers to specific procedures to carry out to prevent injuries to the repairer.



Personal safety Failure to completely observe these instructions will result in serious risk of personal injury.



Safeguarding the environment Sections marked with this symbol indicate the correct use of the vehicle to prevent damaging the environment.



Vehicle intactness The incomplete or non-observance of these regulations leads to the risk of serious damage to the vehicle and sometimes even the invalidity of the guarantee



INDEX OF TOPICS

CHARACTERISTICS

CHAR

SPECIAL TOOLS

S-TOOLS

MAINTENANCE

MAIN

ELECTRICAL SYSTEM

ELE SYS

ENGINE FROM VEHICLE

ENG VE

POWER SUPPLY

P SUPP

SUSPENSIONS

SUSP

CHASSIS

CHAS

BODYWORK

BODYW

PRE-DELIVERY

PRE DE

INDEX OF TOPICS

CHARACTERISTICS

CHAR

Rules

Safety rules

Carbon monoxide

If you need to keep the engine running while working on the vehicle, please ensure that you do so in an open or very well ventilated area. Never let the engine run in an enclosed area. If you do work in an enclosed area, make sure to use a fume extraction system.

CAUTION



EXHAUST EMISSIONS CONTAIN CARBON MONOXIDE, A POISONOUS GAS WHICH CAN CAUSE LOSS OF CONSCIOUSNESS AND EVEN DEATH.

Fuel

CAUTION



THE FUEL USED TO POWER INTERNAL COMBUSTION ENGINES IS HIGHLY FLAMMABLE AND MAY BE EXPLOSIVE UNDER CERTAIN CONDITIONS. IT IS THEREFORE RECOMMENDED TO CARRY OUT REFUELLING AND MAINTENANCE PROCEDURES IN A VENTILATED AREA WITH THE ENGINE SWITCHED OFF. DO NOT SMOKE DURING REFUELLING OR NEAR FUEL VAPOUR. AVOID ANY CONTACT WITH NAKED FLAME, SPARKS OR OTHER HEAT SOURCES WHICH MAY CAUSE IGNITION OR EXPLOSION.

**DO NOT ALLOW FUEL TO DISPERSE INTO THE ENVIRONMENT.
KEEP OUT OF THE REACH OF CHILDREN.**

Hot components

The engine and the exhaust system components become very hot and remain hot for some time after the engine has been switched off. Before handling these components, make sure that you are wearing insulating gloves or wait until the engine and the exhaust system have cooled down.

Used engine oil and transmission oil

CAUTION



**IT IS ADVISABLE TO WEAR LATEX GLOVES WHEN SERVICING THE VEHICLE.
THE ENGINE OR GEARBOX OIL MAY CAUSE SERIOUS INJURIES TO THE SKIN IF HANDLED FOR PROLONGED PERIODS OF TIME AND ON A REGULAR BASIS.
WASH YOUR HANDS CAREFULLY AFTER HANDLING OIL.
HAND THE OIL OVER TO OR HAVE IT COLLECTED BY THE NEAREST USED OIL RECYCLING COMPANY OR THE SUPPLIER.
DO NOT DISPOSE OF OIL IN THE ENVIRONMENT
KEEP OUT OF THE REACH OF CHILDREN.**

Brake and clutch fluid



BRAKE AND CLUTCH FLUIDS CAN DAMAGE THE PLASTIC OR RUBBER PAINTED SURFACES. WHEN SERVICING THE BRAKING OR THE CLUTCH SYSTEM PROTECT THESE COMPONENTS WITH A CLEAN CLOTH. ALWAYS WEAR PROTECTIVE GOGGLES WHEN SERVICING THESE SYSTEMS. BRAKE AND CLUTCH FLUIDS ARE EXTREMELY HARMFUL FOR YOUR EYES. IN THE EVENT OF ACCIDENTAL CONTACT WITH THE EYES, RINSE THEM IMMEDIATELY WITH PLENTY OF COLD, CLEAN WATER AND SEEK MEDICAL ADVICE. KEEP OUT OF THE REACH OF CHILDREN.

Battery electrolyte and hydrogen gas

CAUTION



THE BATTERY ELECTROLYTE IS TOXIC, CORROSIVE AND, AS IT CONTAINS SULPHURIC ACID, MAY CAUSE BURNING IF IT COMES INTO CONTACT WITH THE SKIN. WHEN HANDLING BATTERY ELECTROLYTE, WEAR TIGHT-FITTING GLOVES AND PROTECTIVE APPAREL. IN THE EVENT OF SKIN CONTACT WITH THE ELECTROLYTIC FLUID, RINSE WELL WITH PLENTY OF CLEAN WATER. IT IS PARTICULARLY IMPORTANT TO PROTECT YOUR EYES BECAUSE EVEN TINY AMOUNTS OF BATTERY ACID MAY CAUSE BLINDNESS. IN THE EVENT OF CONTACT WITH THE EYES, RINSE WITH PLENTY OF WATER FOR FIFTEEN MINUTES AND CONSULT AN EYE SPECIALIST IMMEDIATELY. IF THE FLUID IS ACCIDENTALLY SWALLOWED, DRINK LARGE QUANTITIES OF WATER OR MILK, FOLLOWED BY MILK OF MAGNESIA OR VEGETABLE OIL AND SEEK MEDICAL ADVICE IMMEDIATELY. THE BATTERY RELEASES EXPLOSIVE GASES; KEEP IT AWAY FROM FLAMES, SPARKS, CIGARETTES OR ANY OTHER HEAT SOURCES. ENSURE ADEQUATE VENTILATION WHEN SERVICING OR RECHARGING THE BATTERY.

KEEP OUT OF THE REACH OF CHILDREN.

BATTERY LIQUID IS CORROSIVE. DO NOT POUR IT OR SPILL IT, PARTICULARLY ON PLASTIC COMPONENTS. ENSURE THAT THE ELECTROLYTIC ACID IS COMPATIBLE WITH THE BATTERY BEING ACTIVATED.

Maintenance rules

GENERAL PRECAUTIONS AND INFORMATION

When repairing, dismantling and reassembling the vehicle follow the recommendations reported below carefully.

BEFORE REMOVING COMPONENTS

- Before dismantling components, remove dirt, mud, dust and foreign bodies from the vehicle. Use the special tools designed for this bike, as required.

COMPONENTS REMOVAL

- Do not loosen and/or tighten screws and nuts using pliers or any other tools than the specific wrench.
 - Mark the positions on all connection joints (pipes, cables, etc.) before separating them, and identify them with different distinctive symbols.
 - Each component needs to be clearly marked to enable identification during reassembly.
 - Clean and wash the dismantled components carefully using a low-flammability detergent.
-

- Keep mated parts together since they have "adjusted" to each other due to normal wear.
- Some components must be used together or replaced altogether.
- Keep away from heat sources.

REASSEMBLY OF COMPONENTS

CAUTION

BEARINGS MUST BE ABLE TO ROTATE FREELY, WITHOUT JAMMING AND/OR NOISE: OTHERWISE, THEY NEED TO BE REPLACED.

- Only use ORIGINAL Moto Guzzi SPARE PARTS.
- Comply with lubricant and consumables use guidelines.
- Lubricate parts (whenever possible) before reassembling them.
- When tightening nuts and screws, start from the ones with the largest section or from the internal ones, moving diagonally. Tighten nuts and screws in successive steps before applying the tightening torque.
- Always replace self-locking nuts, washers, sealing rings, circlips, O-rings (OR), split pins and screws with new ones if their tread is damaged.
- When assembling the bearings, make sure to lubricate them well.
- Check that each component is assembled correctly.
- After a repair or routine maintenance procedure, carry out pre-ride checks and test the vehicle on private grounds or in an area with low traffic density.
- Clean all coupling surfaces, oil guard rims and gaskets before refitting them. Smear a light layer of lithium-based grease on the oil guard rims. Reassemble oil guards and bearings with the brand or lot number facing outward (visible side).

ELECTRIC CONNECTORS

Electric connectors must be disconnected as described below; failure to comply with this procedure causes irreparable damage to both the connector and the cable harness:

Press the relevant safety hooks, if any.

- Grip the two connectors and disconnect them by pulling them in opposite directions.
- If any signs of dirt, rust, moisture, etc. are noted, clean the inside of the connector carefully with a jet of compressed air.
- Ensure that the cables are correctly fastened to the internal connector terminals.
- Then connect the two connectors, ensuring that they couple correctly (if fitted with clips, you will hear them "click" into place).

CAUTION

TO DISCONNECT THE TWO CONNECTORS, DO NOT PULL THE CABLES.

NOTE

THE TWO CONNECTORS CONNECT ONLY FROM ONE SIDE: CONNECT THEM THE RIGHT WAY ROUND.

TIGHTENING TORQUES

CAUTION

IN THE EVENT THAT A SELFBRAKING NUT IS UNSCREWED, IT IS NECESSARY TO REPLACE IT WITH A NEW ONE.

CAUTION

DO NOT FORGET THAT THE TIGHTENING TORQUES OF ALL FASTENING ELEMENTS ON WHEELS, BRAKES, WHEEL BOLTS AND ANY OTHER SUSPENSION COMPONENTS PLAY A KEY ROLE IN ENSURING VEHICLE SAFETY AND MUST COMPLY WITH SPECIFIED VALUES. CHECK THE TIGHTENING TORQUES OF FASTENING PARTS ON A REGULAR BASIS AND ALWAYS USE A TORQUE WRENCH TO REASSEMBLE THESE COMPONENTS. FAILURE TO COMPLY WITH THESE RECOMMENDATIONS MAY CAUSE ONE OF THESE COMPONENTS TO GET LOOSE AND EVEN DETACHED, THUS BLOCKING A WHEEL, OR OTHERWISE COMPROMISE VEHICLE HANDLING. THIS CAN LEAD TO FALLS, WITH THE RISK OF SERIOUS INJURY OR DEATH.

Running-in

Engine run-in is essential to ensure engine long life and correct operation. Twisty roads and gradients are ideal to run in engine, brakes and suspensions effectively. Vary your riding speed during the run-in. This ensures that components operate under both "loaded" and "unloaded" conditions, allowing the engine components to cool.

CAUTION

THE CLUTCH MAY EMIT A SLIGHT BURNING SMELL WHEN FIRST USED. THIS PHENOMENON SHOULD BE CONSIDERED NORMAL AND WILL DISAPPEAR AS SOON AS THE CLUTCH DISCS GET ADAPTED.

IT IS IMPORTANT TO STRAIN ENGINE COMPONENTS DURING RUN-IN, HOWEVER, MAKE SURE NOT TO OVERDO THIS.

CAUTION

THE FULL PERFORMANCE OF THE VEHICLE IS ONLY AVAILABLE AFTER THE SERVICE AT THE END OF THE RUNNING IN PERIOD.

Follow the guidelines detailed below:

- Do not twist the throttle grip abruptly and completely when the engine is working at a low revs, either during or after run-in.
- During the first 100 Km (62 miles) use the brakes gently, avoiding sudden or prolonged braking. That is to permit the adequate adjustment of the pad friction material to the brake discs.



AFTER THE SPECIFIED MILEAGE, TAKE THE VEHICLE TO AN OFFICIAL Moto Guzzi DEALER FOR THE CHECKS INDICATED IN THE "AFTER RUN-IN" TABLE IN THE SCHEDULED MAINTENANCE SECTION TO AVOID INJURING YOURSELF, OTHERS AND /OR DAMAGING THE VEHICLE.

Vehicle identification

SERIAL NUMBER LOCATION

These numbers are necessary for vehicle registration.

NOTE

ALTERING IDENTIFICATION NUMBERS MAY BE SERIOUSLY PUNISHABLE BY LAW. IN PARTICULAR, MODIFYING THE CHASSIS NUMBER IMMEDIATELY VOIDS THE WARRANTY.

This number consists of numbers and letters, as in the example shown below.

ZGULWE0012MXXXXXX

KEY:

ZGU: WMI (World manufacturer identifier) code;

LW: model;

E00 (V7 Stone), **G00** (V7 Special), **H00** (V7 Racer): versions;

0: free digit

12: variable year of manufacture (12 - for 2012)

M: production plant (M= Mandello del Lario);

XXXXXX: serial number (6 digits);

CHASSIS NUMBER

The chassis number is stamped on the right hand side of the headstock.

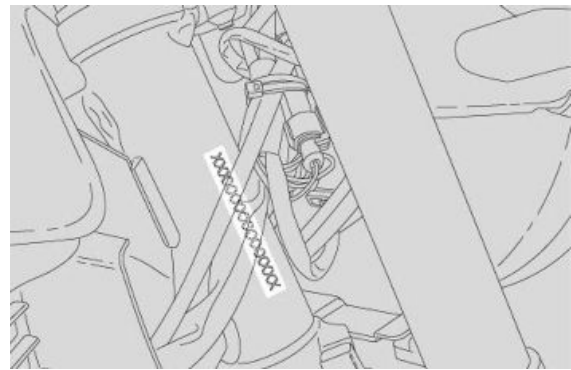

ENGINE NUMBER

The engine number is stamped on the left side, close to the engine oil level check cap.

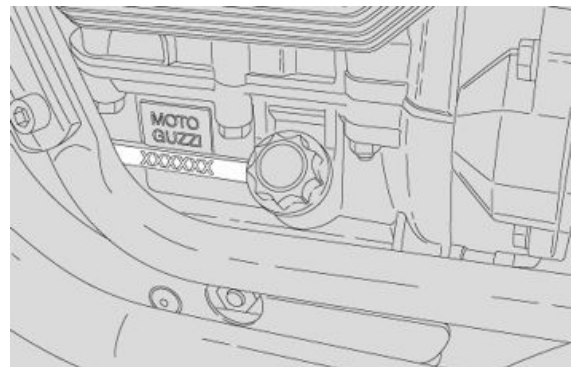

Dimensions and mass

WEIGHT AND DIMENSIONS

Specification	Desc./Quantity
Max. length	2185 mm (86 in)
Max. width - V7 Special / V7 Stone	800 mm (31.5 in)
Max. width - V7 Racer	730 mm (28.74 in)
Max. height	1115 mm (43.9 in)
Saddle height	805 mm (31.69 in)
Wheelbase	1435 mm (56.5 in)
Minimum ground clearance	182 mm (7.16 in)
Kerb weight	198 kg (436 lb)

Engine

ENGINE

Specification	Desc./Quantity
Type	traverse-mounted twin-cylinder four-stroke V 90°
No. of cylinders	2

Specification	Desc./Quantity
Engine capacity	744 cm ³ (45.40 cu.in)
Bore / stroke	80x74 mm (3.14x2.91 in)
Compression ratio	10.4 : 1
Electric	Electric starter
Engine idle speed	1350 +/- 100 rpm
Intake valve clearance	0.15 mm (0.0059 in)
Exhaust valve clearance	0.20 mm (0.0079 in)
Clutch	dry single-disc clutch with flexible coupling
Lubrication	Pressure-fed, controlled by valves and trochoidal pump
Air filter	cartridge-type dry filter
Cooling	air

Transmission

TRANSMISSION

Specification	Desc./Quantity
Gearbox / Type	mechanical, 5 speeds with foot lever on the left-hand side of the engine.
Primary drive	with gears, ratio: 16 / 21 = 1 : 1.3125
Gear ratios, 1st gear	11 / 26 = 1 : 2.3636
Gear ratios, 2nd gear	14 / 23 = 1 : 1.6429
Gear ratios, 3rd gear	18 / 23 = 1 : 1.2778
Gear ratios, 4th gear	18 / 19 = 1 : 1.0556
Gear ratios, 5th gear	22 / 25 = 1 : 0.9
Final drive	with cardan shaft, ratio: 8 / 33 = 1 : 4.825

Capacities

CAPACITY

Specification	Desc./Quantity
Fuel tank (reserve included)	21 l (4.62 UKgal; 5.55 US gal)
Fuel tank reserve	4 l (0.88 UKgal; 1.06 US gal)
Engine oil	Oil change and oil filter replacement: 2000 cm ³ (122.05 cu.in)
Gearbox oil	1 l (0.26 USgal)
Transmission oil	170 cm ³ (10.37 cu.in)
Seats - V7 Special / V7 Stone	2
Seats - V7 Racer	1 + 1*
Maximum carrying load	203 kg (447 lb) (rider + passenger + luggage)
*	2 seats, if vehicle is fitted with long two-seater saddle, passenger footpegs, passenger grab handles (necessitating rear shock absorbers to be installed upside-down) and exhaust mounts. In this case, the user is responsible for finding out the correct procedures for revising the vehicle's road registration documentation from the relevant local authorities.

Electrical system

ELECTRICAL SYSTEM

Specification	Desc./Quantity
Battery	12V - 12 Ah
Fuses	5 (2) - 10 - 15 (2) - 30 A
Generator (alternator + rectifier)	12V - 350 W

SPARK PLUGS

Specification	Desc./Quantity
Standard	NGK CPR8EB-9

Specification	Desc./Quantity
Alternatively:	CHAMPION RG6YC
Spark plug electrode gap	0.6 - 0.7 mm (0.024 - 0.027 in)
Resistance	5 kOhm

BULBS

Specification	Desc./Quantity
Low/high beam light (halogen)	12 V - 55 W / 60 W H4
Front daylight running light	12V - 5W
Turn indicator light	12 V - 10 W (orange RY 10 W bulb)
tail light /stop lights	12 V - 5 / 21 W
Dashboard lighting	LED

WARNING LIGHTS

Specification	Desc./Quantity
Gear in neutral	LED
Turn indicators	LED
Fuel reserve	LED
High beam light	LED
Engine oil pressure	LED
Injection check warning light	LED

Frame and suspensions

CHASSIS

Specification	Desc./Quantity
Type	Modular double cradle, high strength steel tubular chassis
Steering rake	27.5°
Trail	138 mm (5.43 in)

SUSPENSIONS

Specification	Desc./Quantity
Front	hydraulic telescopic fork, Ø 40 mm (1.57 in)
Travel	130 mm (5.12 in)
Rear - V7 Special / V7 Stone	swinging arm in die-cast light alloy, 2 shock absorbers with adjustable spring preloading
Rear - V7 Racer	die-cast light alloy swingarm with 2 adjustable shock absorbers
Wheel travel	100 mm (3.93 in)

SIZES A AND B

Specification	Desc./Quantity
Size A	692 mm (27.24 in)
Size B	186 mm (7.32 in)

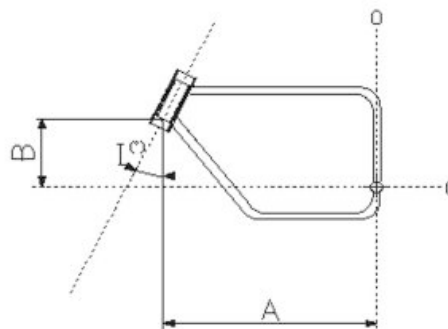

Brakes

BRAKES

Specification	Desc./Quantity
Front	stainless steel floating disc, Ø 320 mm (12.59 in), callipers with 4 different and counteracting plungers
Rear	260 mm (10.24 in) stainless steel disc, floating calliper with two 25.4 mm (1.00 in) diam. pistons

Wheels and tyres

WHEEL RIMS

Specification	Desc./Quantity
Type - V7 Stone	Alloy wheels for tubeless tyres
Type - V7 Special / V7 Racer	with spokes, for tyres with inner tubes
Front	2.5"x18"
Rear	3.50 x 17"

TYRES

Specification	Desc./Quantity
Front tyre	PIRELLI SPORT DEMON
Front (size)	100 / 90 - 18 56H TL
Front (inflation pressure)	2.5 bar (250 kPa) (36.3 PSI)
Front (inflation pressure with passenger)	2.6 bar (260 kPa) (37.71 PSI)
Rear tyre	PIRELLI SPORT DEMON
Rear (size)	130 / 80 - 17 65H TL
Rear (inflation pressure)	2.5 bar (250 kPa) (36.3 PSI)
Rear (inflation pressure with passenger)	2.6 bar (260 kPa) (37.71 PSI)

Supply

FUEL SYSTEM

Specification	Desc./Quantity
Type	Electronic injection (Marelli MIU G3)
Venturi	Ø 38 mm (1.50 in)
Fuel	Premium unleaded petrol, minimum octane rating of 95 (NORM) and 85 (NOMM)

Tightening Torques

Chassis

Front side

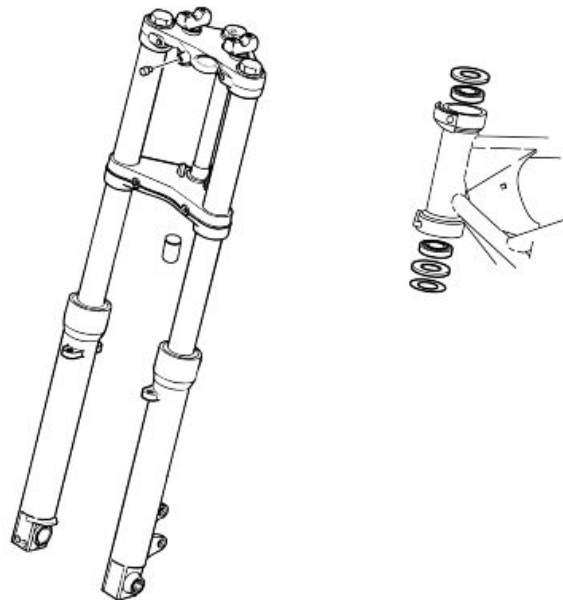
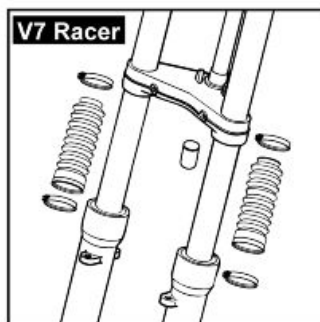
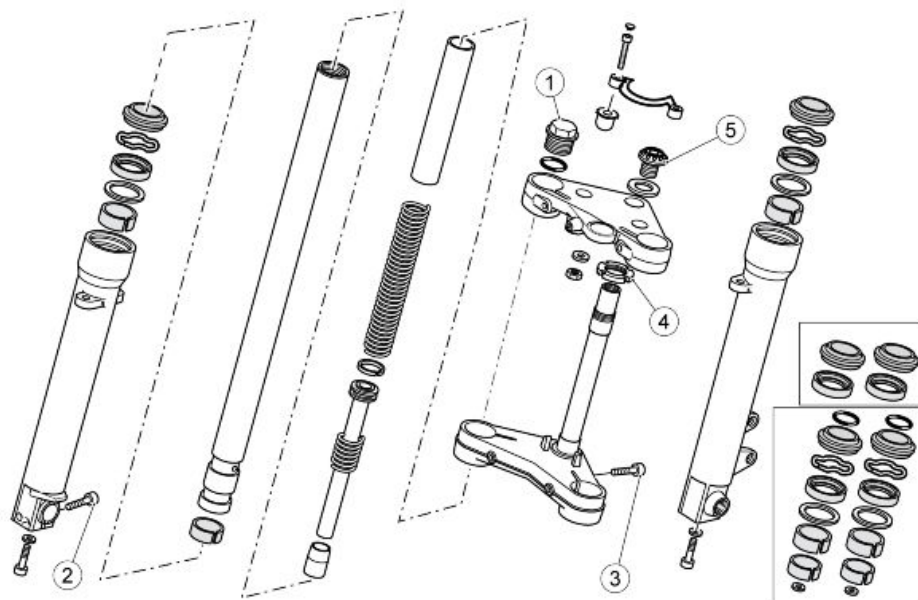

FRONT SUSPENSION - STEERING

pos.	Description	Type	Quantity	Torque	Notes
1	Stanchion cap	-	2	50 Nm (36.88 lbf ft)	-
2	Screw fixing wheel axle to right fork leg	M6x30	2	10 Nm (7.37 lbf ft)	Tighten using a 1-2-1 sequence
3	Screw fixing stanchions to upper and lower plate	M10x40	4	50 Nm (36.88 lbf ft)	-
4	Headstock ring nut	M25x1	1	7 Nm (5.16 lbf ft)	The fork must fall to one side by itself

pos.	Description	Type	Quantity	Torque	Notes
5	Headstock bushing	M23x1	1	50 Nm (36.88 lbf ft)	-

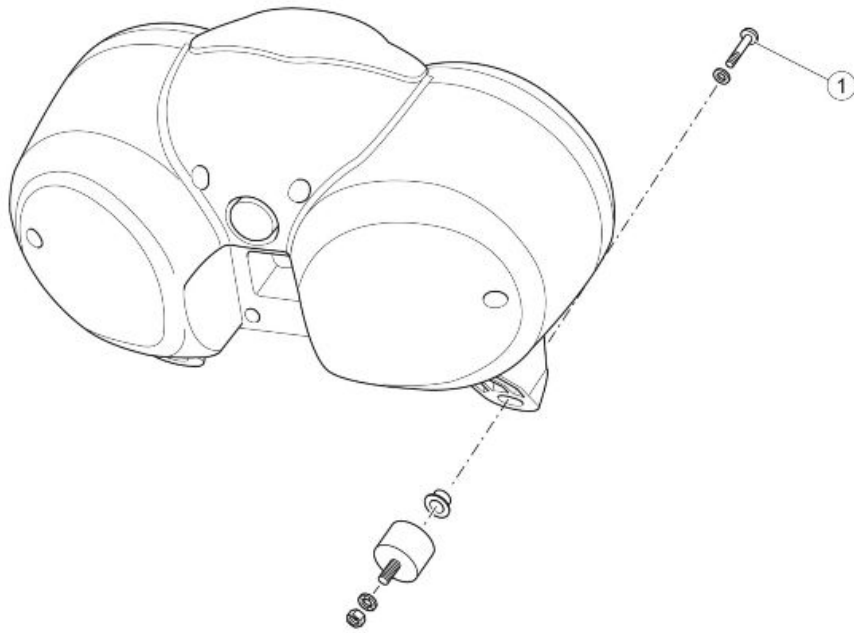

INSTRUMENT PANEL

pos.	Description	Type	Quantity	Torque	Notes
1	Screw fixing instrument panel to headlamp support	M6x10	3	10 Nm (7.37 lbf ft)	-

(V7 SPECIAL / V7 STONE)

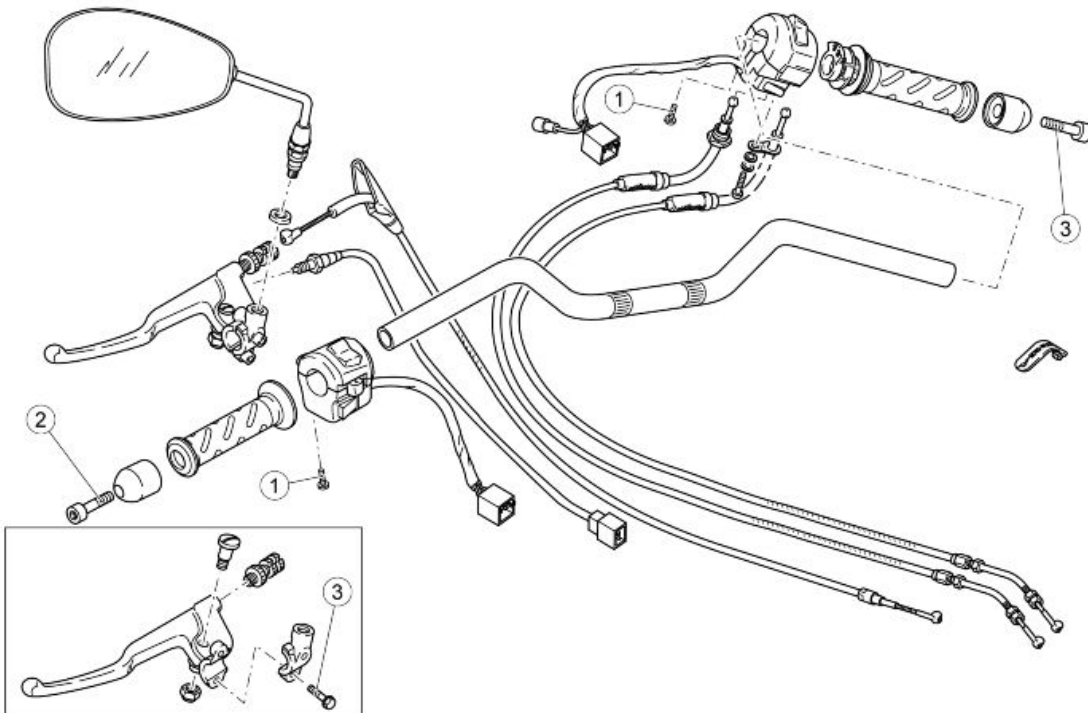

HANDLEBAR AND CONTROLS

Pos.	Description	Type	Quantity	Torque	Notes
1	Switch fastener screw	SWP 5	1+1	1.5 Nm (1.11 lb ft)	-
2	Counterweight fixing screw	M6	2	10 Nm (7.37 lb ft)	Loctite 243
3	Screw fastening the clutch control U-bolt to the semi-handlebar	M6x25	2	10 Nm (7.37 lb ft)	-

(V7 RACER)

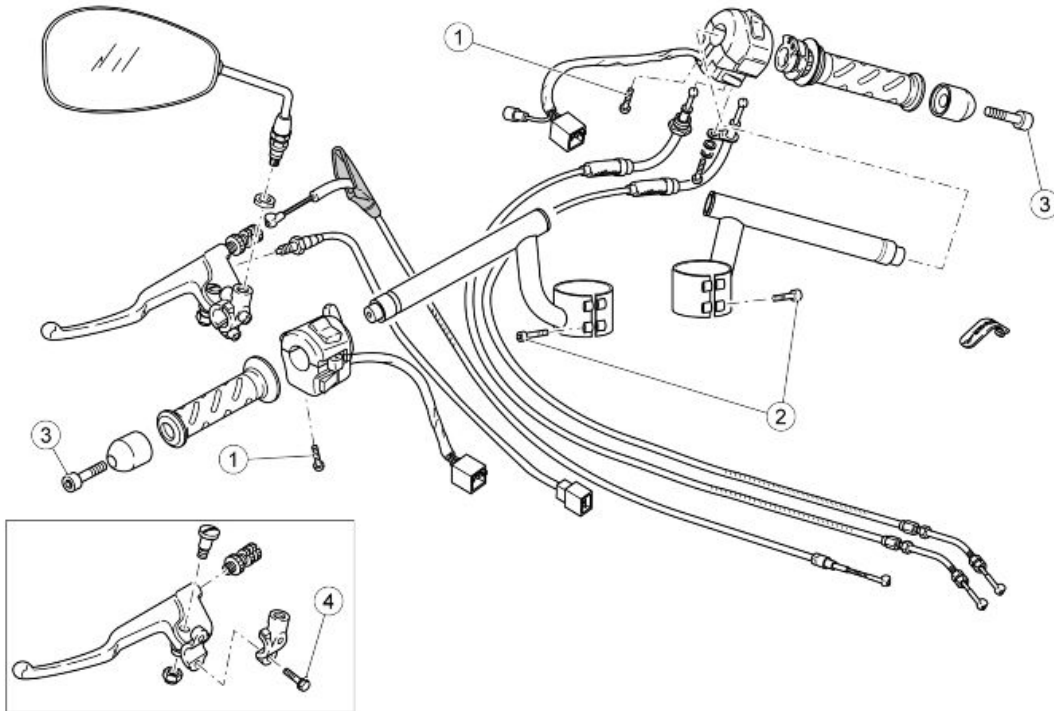

HANDLEBAR AND CONTROLS

Pos.	Description	Type	Quantity	Torque	Notes
1	Switch fastener screw	M5	1+1	1.5 Nm (1.11 lb ft)	Tighten using a 1-2-1 sequence
2	Semi-handlebar fixing screw	M6x25	4	10 Nm (7.37 lb ft)	Tighten using a 1-2-1 sequence
3	Counterweight fixing screw	M6	2	10 Nm (7.37 lb ft)	Loctite 243
4	Screw fastening the clutch control U-bolt to the semi-handlebar	M6x25	2	10 Nm (7.37 lb ft)	Tighten using a 1-2-1 sequence

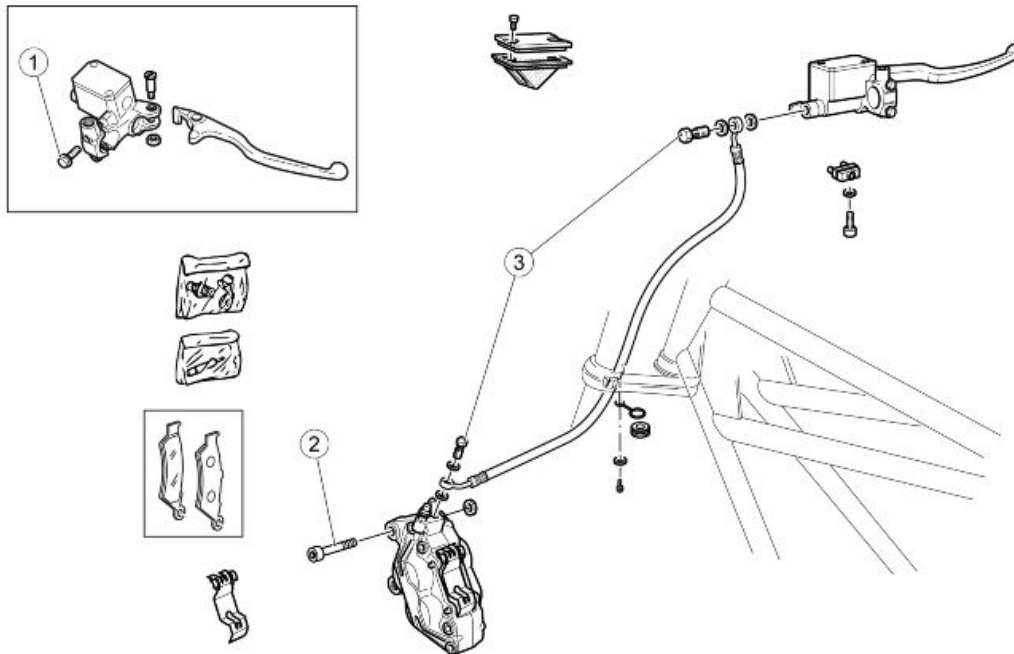

FRONT BRAKE SYSTEM

pos.	Description	Type	Quantity	Torque	Notes
1	Screw fastening the brake pump U-bolt to the semi-handlebar	M6x25	2	10 Nm (7.37 lb ft)	-
2	Front brake calliper fixing screw	M10x30	2	50 Nm (36.88 lb ft)	-
3	Drilled screw for brake fluid pipe on pump and calliper	-	2	25 Nm (18.44 lb ft)	-

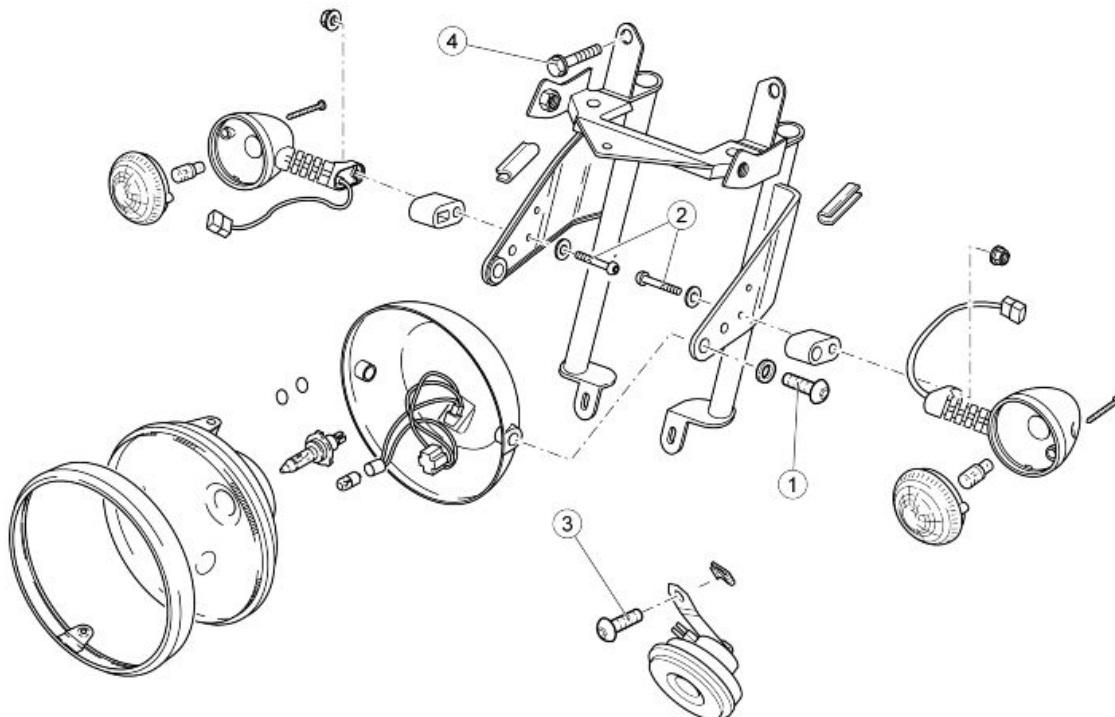

FRONT LIGHTS

pos.	Description	Type	Quantity	Torque	Notes
1	Headlamp fixing screw	M8x30	2	15 Nm (11.06 lb ft)	-
2	Front turn indicator fixing screw	M6	2	5 Nm (3.69 lb ft)	-
3	Horn fixing screw	M6x16	2	10 Nm (7.37 lb ft)	-
4	Headlamp support bracket fixing screw	M10x40	2	50 Nm (36.88 lb ft)	-

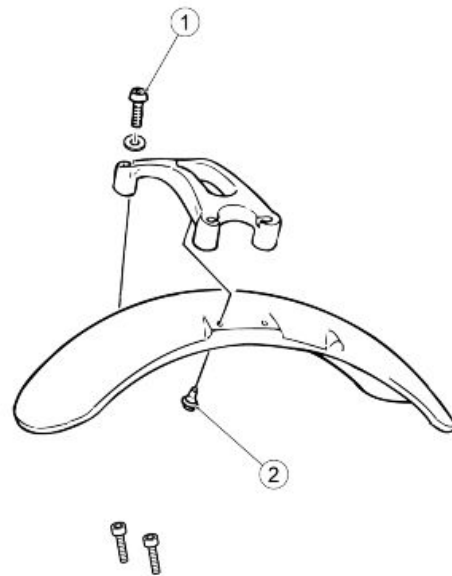
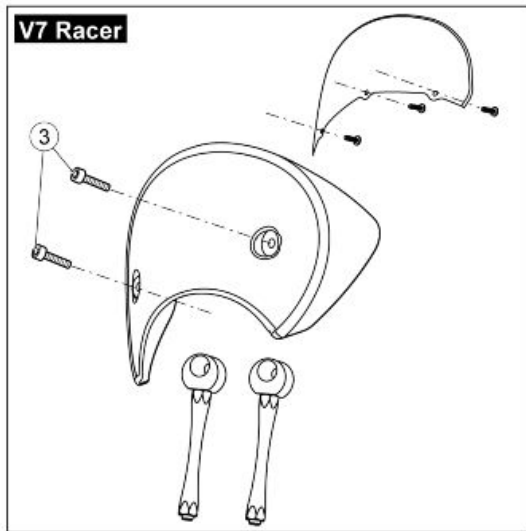

BODYWORK - FRONT SECTION

pos.	Description	Type	Quantity	Torque	Notes
1	Screw fastening stabiliser plate to fork	M8x40	4	15 Nm (11.06 lbf ft)	Loctite 243
2	Screw fastening mudguard to stabiliser plate	M6x11	4	10 Nm (7.37 lbf ft)	Loctite 243
3	Top fairing fixing screw	M6	2	10 Nm (7.37 lbf ft)	

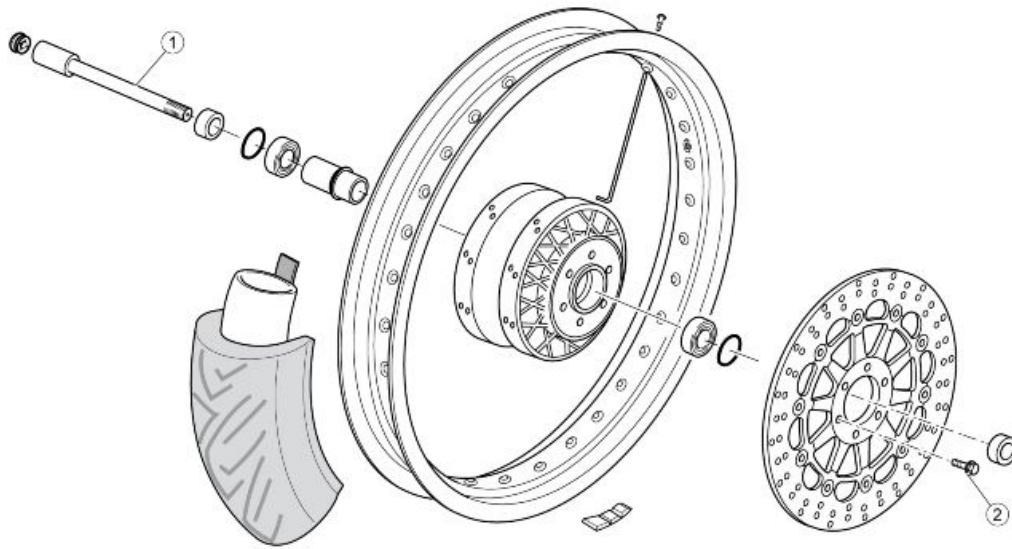

FRONT WHEEL

pos.	Description	Type	Quantity	Torque	Notes
1	Front wheel axle	M18x1.5	1	80 Nm (59.00 lbf ft)	-
2	Front brake disc fixing screw	M8x20	6	25 Nm (18.44 lbf ft)	Loctite 243

Central part

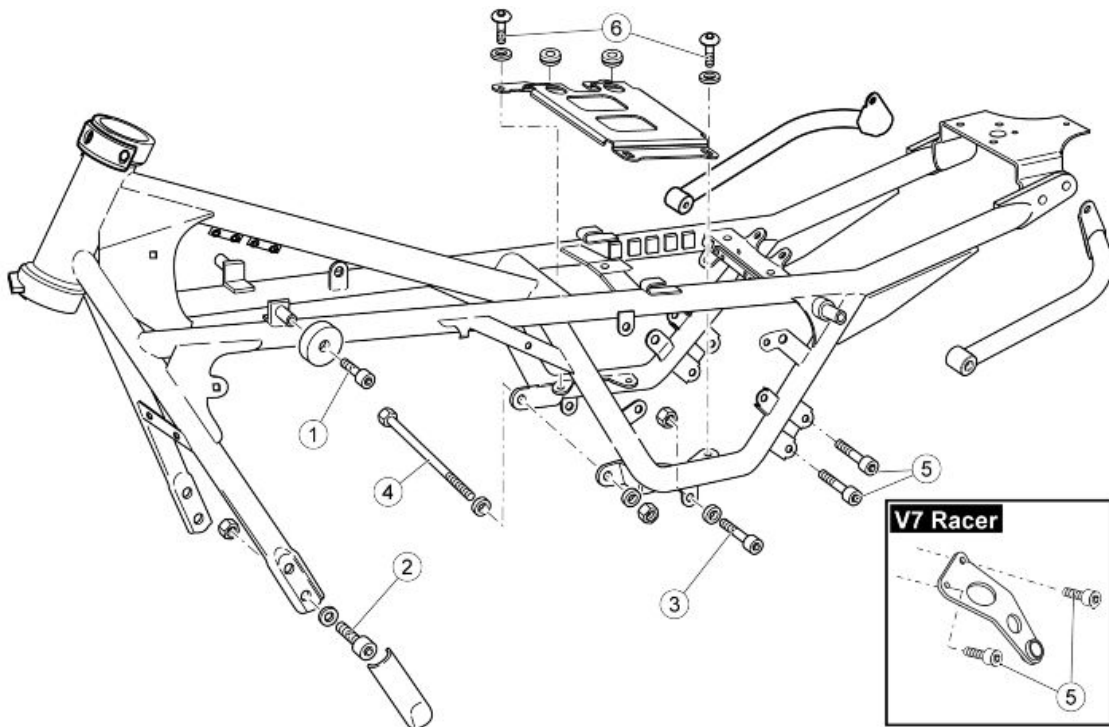

FRAME

pos.	Description	Type	Quantity	Torque	Notes
1	Screw fixing tank mounting rubber blocks to frame	M8x14	2	25 Nm (18.44 lbf ft)	-
2	Cradle front fixing screw	M10x30	4	50 Nm (36.88 lbf ft)	-
3	Screw fastening gearbox to frame	M10x55	2	50 Nm (36.88 lbf ft)	-
4	Pin fixing engine/gearbox to chassis	M10x205	1	50 Nm (36.88 lbf ft)	-
5	Screw fixing exhaust silencer mounting to frame	M8x16	4	25 Nm (18.44 lbf ft)	Loctite 243
6	Battery supporting plate fixing screw	M8x16	4	25 Nm (18.44 lbf ft)	-

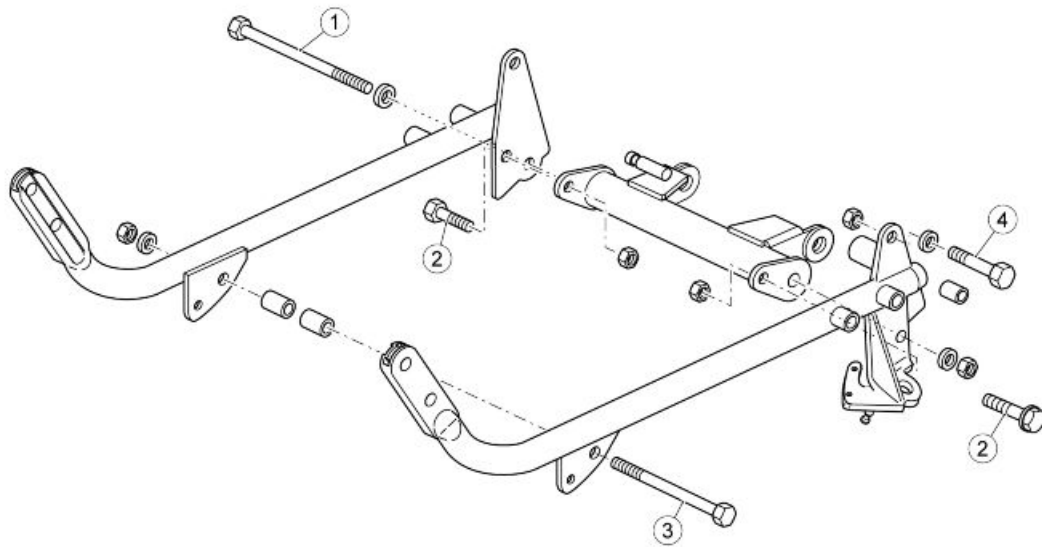

FRAME CRADLES

pos.	Description	Type	Quantity	Torque	Notes
1	Screw fixing stand beam to cradle	M10x260	1	50 Nm (36.88 lbf ft)	-
2	Screw fixing stand beam to cradle	M8	1+1	25 Nm (18.44 lbf ft)	-
3	Pin fixing engine/gearbox to chassis	M10x250	1	50 Nm (36.88 lbf ft)	-
4	Screw fastening cradle to frame	M10x65	2	50 Nm (36.88 lbf ft)	-

(V7 SPECIAL / V7 STONE)

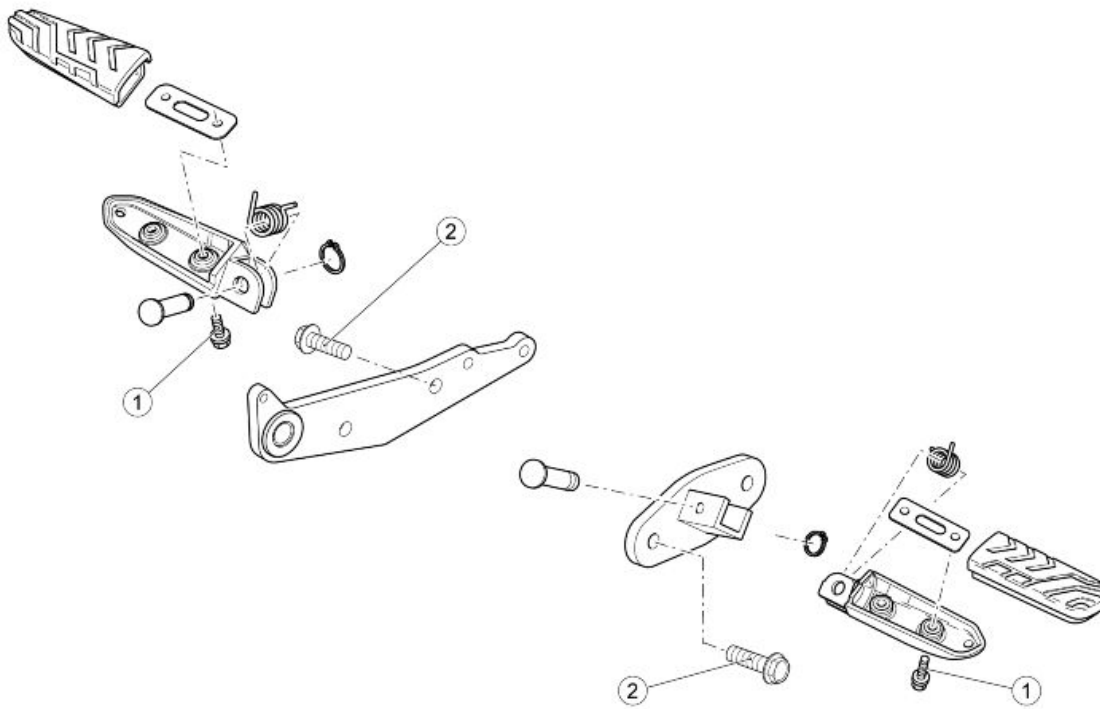

DRIVER FOOTRESTS

pos.	Description	Type	Quantity	Torque	Notes
1	Pedal rubber fastening screw	M6x12	4	10 Nm (7.38 lb ft)	-
2	Screw fastening rider footrest mounting to frame	M8	2+2	25 Nm (18.44 lb ft)	Loct. 243

(V7 RACER)

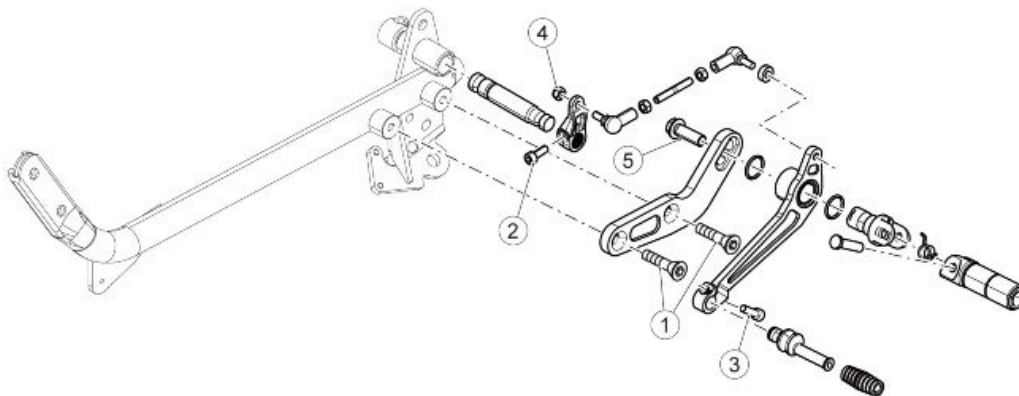

RIDER FOOTREST / GEAR SHIFT LEVER

pos.	Description	Type	Quantity	Torque	Notes
1	Screw fastening left hand rider footrest mounting plate to cradle	M8x20	2	25 Nm (18.44 lb ft)	Loctite 243

pos.	Description	Type	Quantity	Torque	Notes
2	Preselector lever fixing screw	M6x20	1	10 Nm (7.37 lb ft)	-
3	Gearbox lever fixing screws	M6x20	1	10 Nm (7.37 lb ft)	Loctite 243
4	Gearbox control rod fixing nut	M6x1	1	10 Nm (7.37 lb ft)	-
5	Screw fastening rider footrest mounting to plate	M8	1	20 Nm (14.75 lb ft)	Loctite 243

(V7 RACER)

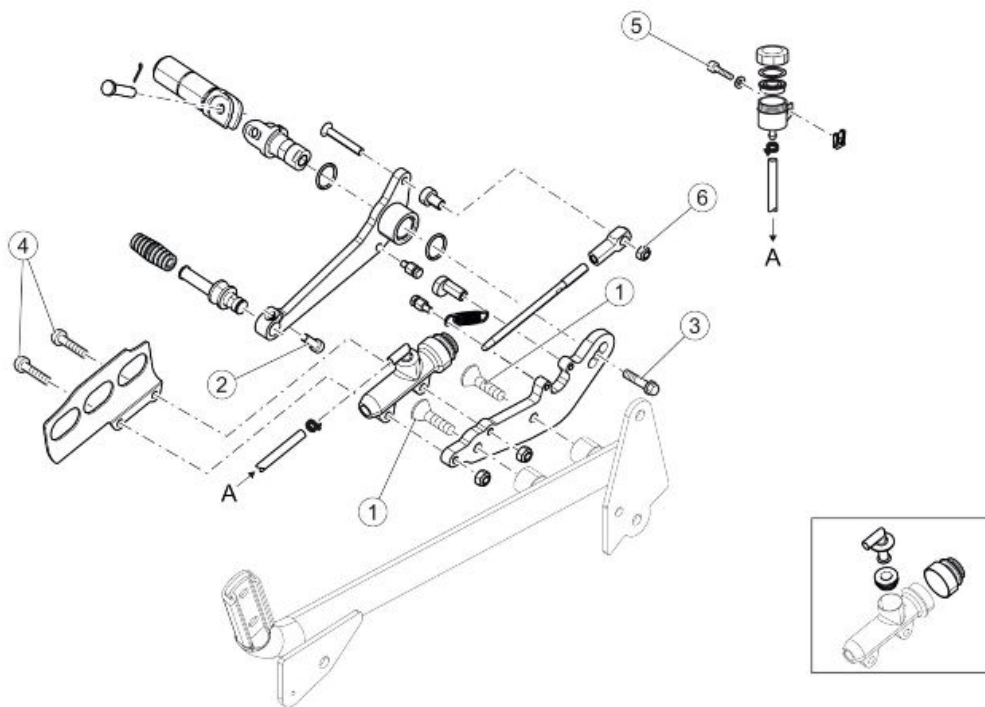

RIDER FOOTREST / REAR BRAKE LEVER

pos.	Description	Type	Quantity	Torque	Notes
1	Screw fastening right hand rider footrest mounting plate to cradle	M8x20	2	20 Nm (14.75 lb ft)	Loctite 243
2	Rear brake lever fixing screw	M6x20	1	10 Nm (7.37 lb ft)	Loctite 243
3	Screw fastening rider footrest mounting to plate	M8	1	25 Nm (18.44 lb ft)	Loctite 243
4	Rear brake pump fixing screw	M6x25	2	8 Nm (5.90 lb ft)	Loctite 243
5	Rear brake fluid reservoir fixing screw	M5x15	1	6 Nm (4.43 lb ft)	-
6	Nut fastening rod terminal on brake lever	M6	1	10 Nm (7.37 lb ft)	-

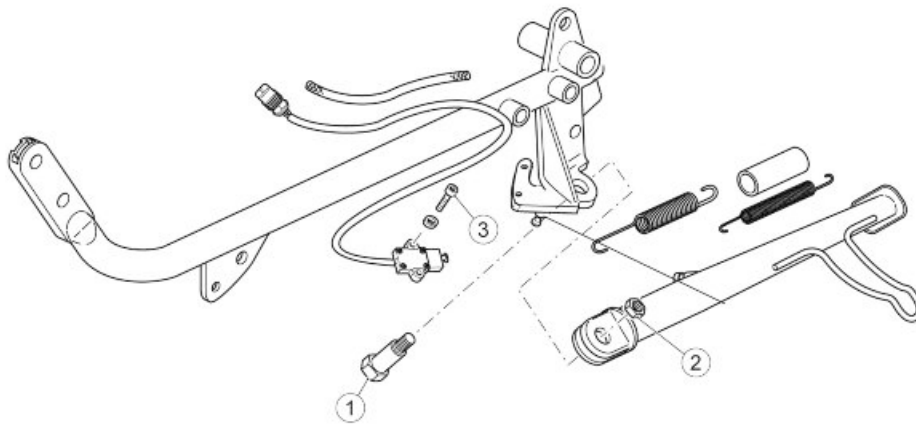

SIDE STAND

pos.	Description	Type	Quantity	Torque	Notes
1	Side stand retainer pin	M10x1.2 5	1	10 Nm (7.38 lb ft)	-
2	Lock nut for stand bolt	M10x1.2 5	1	30 Nm (22.13 lb ft)	-
3	Switch fixing screw	M5x16	2	6 Nm (4.42 lb ft)	-

(V7 RACER)

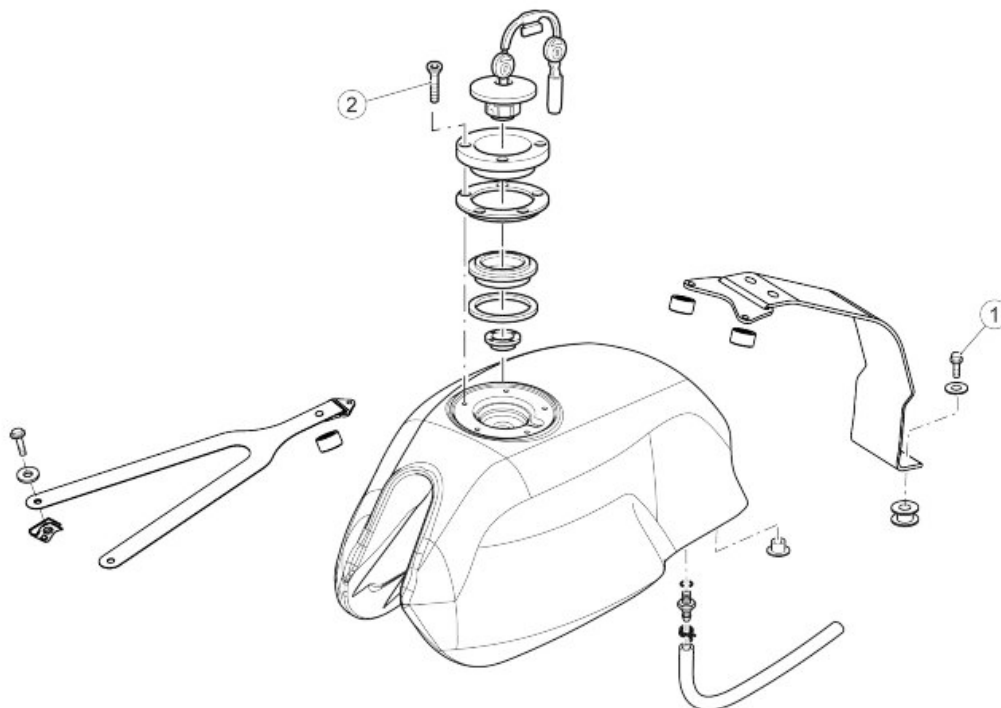

(V7 SPECIAL / V7 STONE)

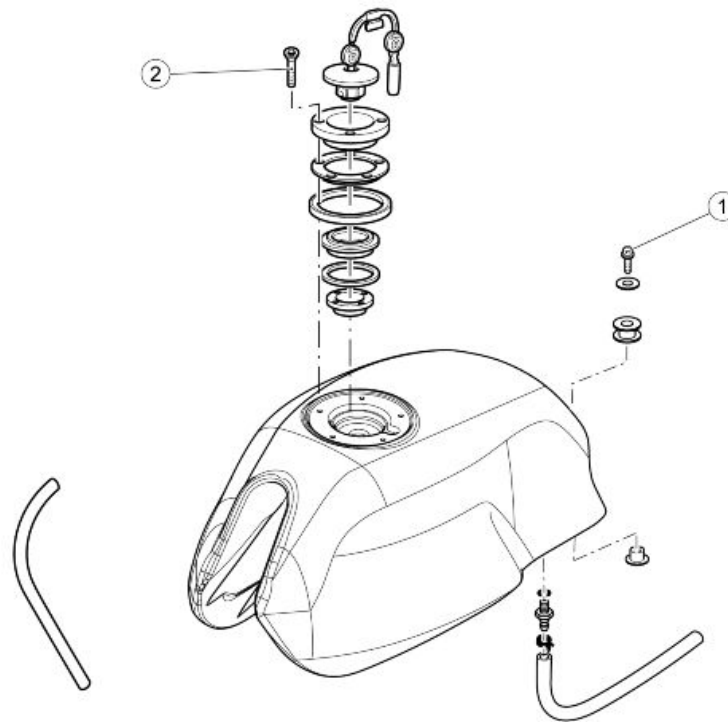

FUEL TANK

pos.	Description	Type	Quantity	Torque	Notes
1	Rear tank fixing screw	M8x45	1	25 Nm (18.44 lb ft)	-
2	Screw fastening cap flange to tank	M5x12	2+3	4 Nm (2.95 lb ft)	-

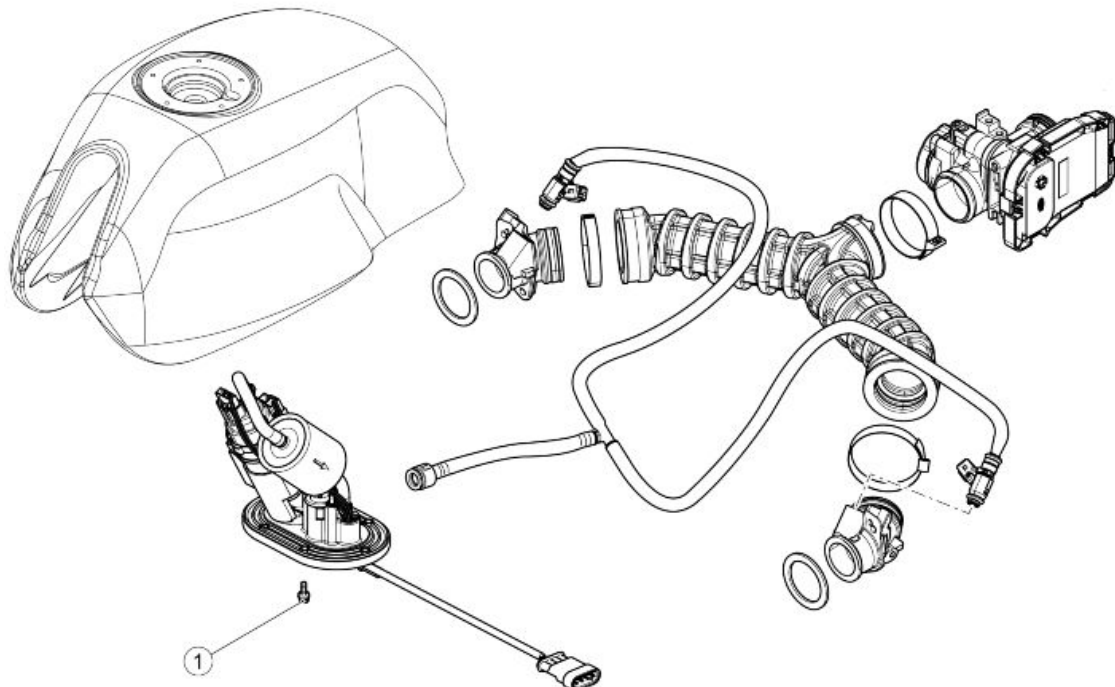

FUEL SUPPLY SYSTEM

pos.	Description	Type	Quantity	Torque	Notes
1	Screw fixing fuel pump mounting to tank	M5x16	6	6 Nm (4.43 lbf ft)	-

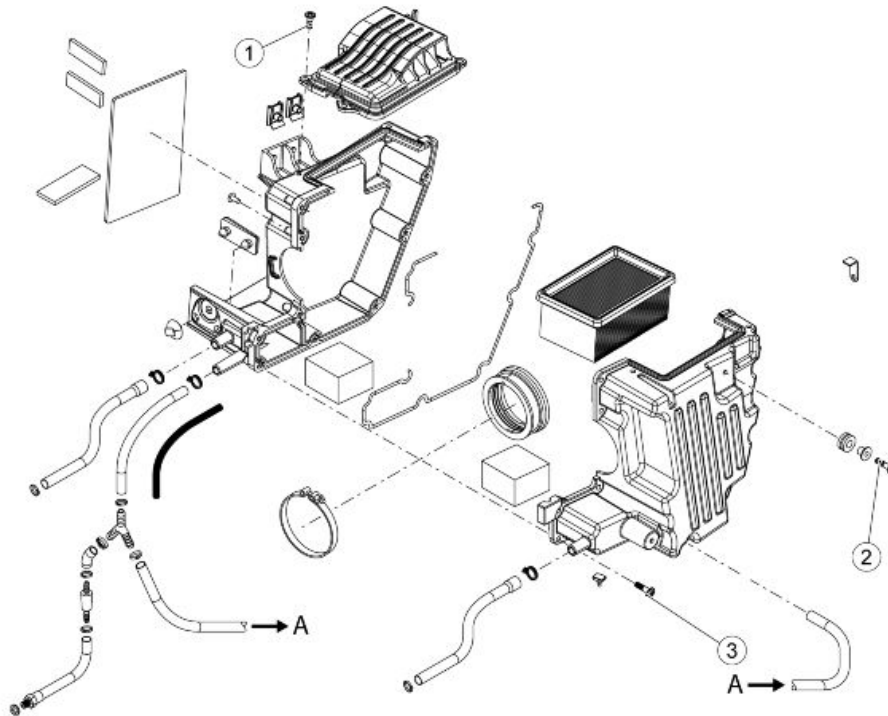

TIGHTENING TORQUE - CENTRAL PART - FILTER BOX

pos.	Description	Type	Quantity	Torque	Notes
1	Air filter box cover fastening screw	SWP 5x14	4	3 Nm (2.21 lb ft)	-
2	Air filter box fastening screw to frame	SWP 5x20	2	3 Nm (2.21 lb ft)	-
3	Air filter box fastening screw	SWP 5x20	9	3 Nm (2.21 lb ft)	-

(V7 SPECIAL / V7 STONE)

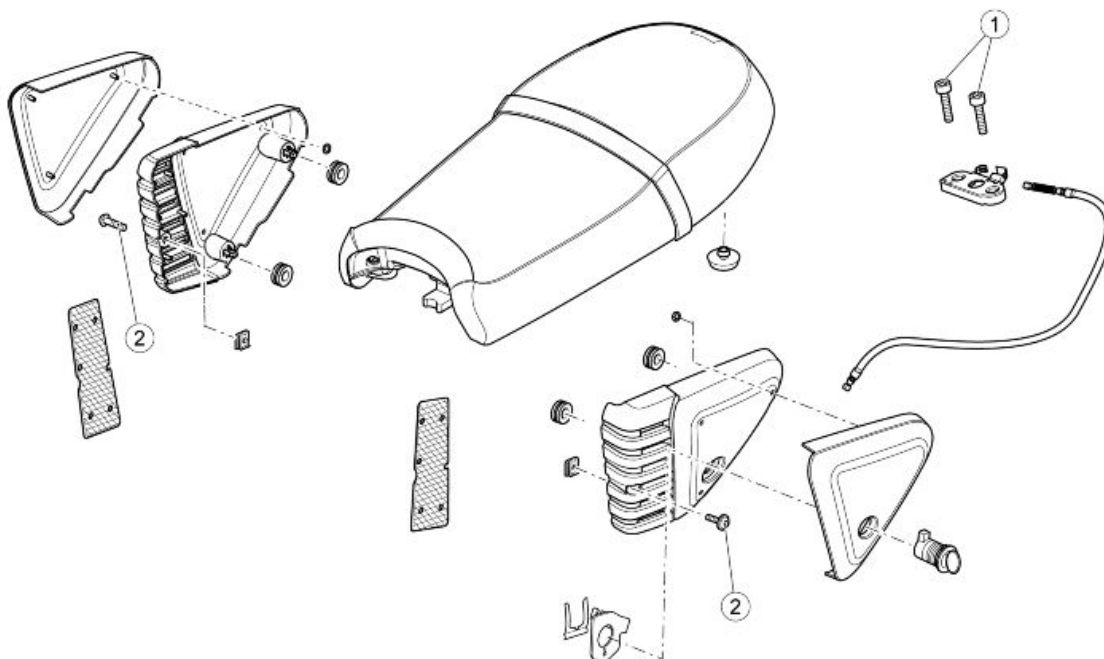

BODYWORK CENTRAL SECTION - SADDLE

pos.	Description	Type	Quantity	Torque	Notes
1	Saddle release block fixing screw	M6x25	2	10 Nm (2.37 lb ft)	-
2	Side fairing fixing screw	M5x9	2	4 Nm (2.95 lb ft)	-

(V7 RACER)

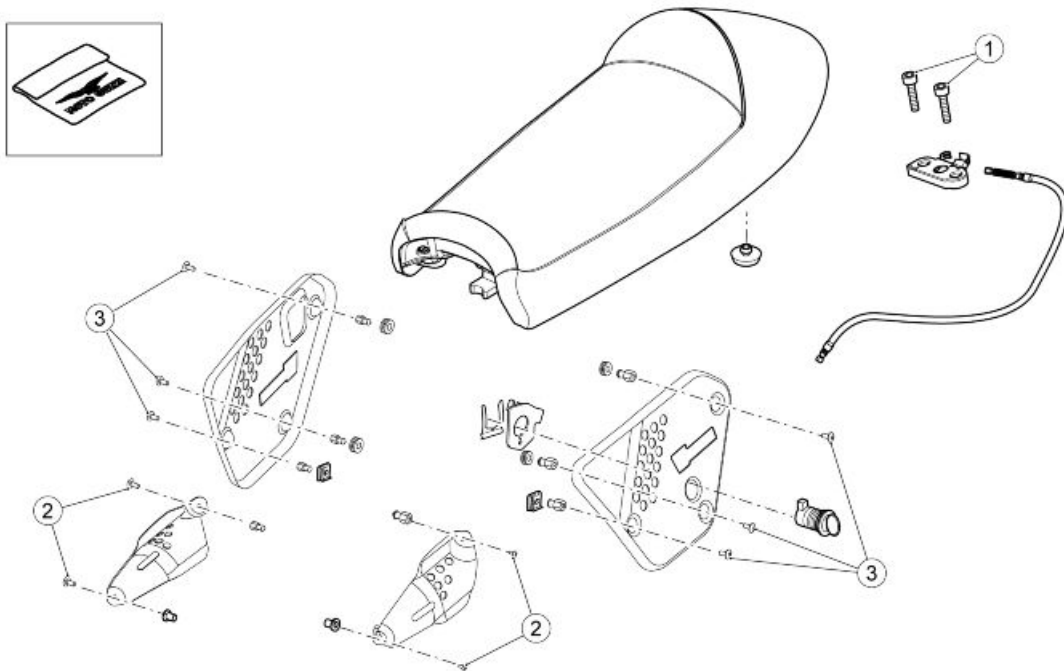

BODYWORK CENTRAL SECTION - SADDLE

pos.	Description	Type	Quantity	Torque	Notes
1	Saddle release block fixing screw	M6x25	2	10 Nm (2.37 lb ft)	-
2	Throttle body cover fastener screw	M5x14	4	4 Nm (2.95 lb ft)	-
3	Side fairing fixing screw	M5x9	6	4 Nm (2.95 lb ft)	-

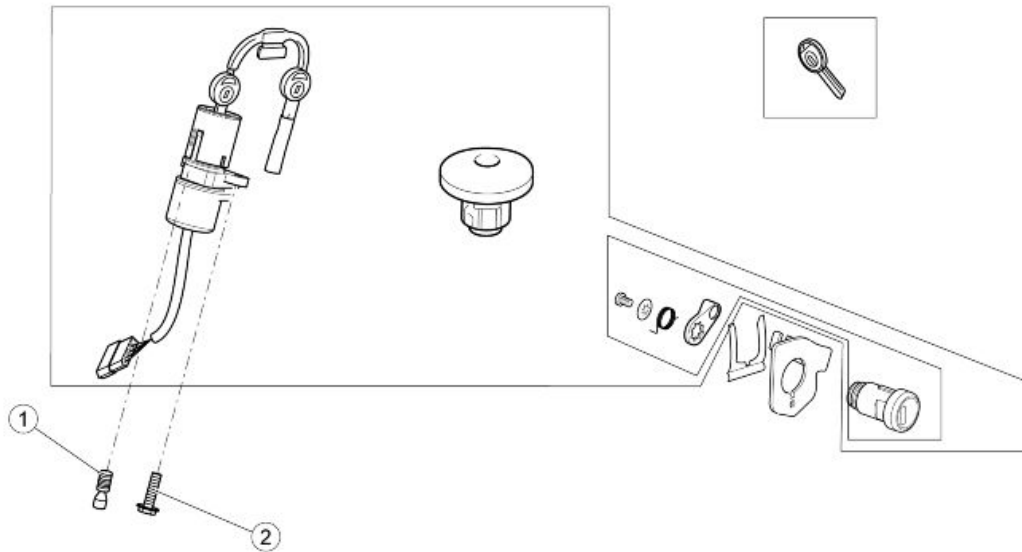

LOCK KIT

pos.	Description	Type	Quantity	Torque	Notes
1	(Shear head) screw fixing ignition lock	M8x15	1	-	At the point of failure
2	Ignition lock fixing screw	M8x16	1	25 Nm (18.44 lb ft)	-

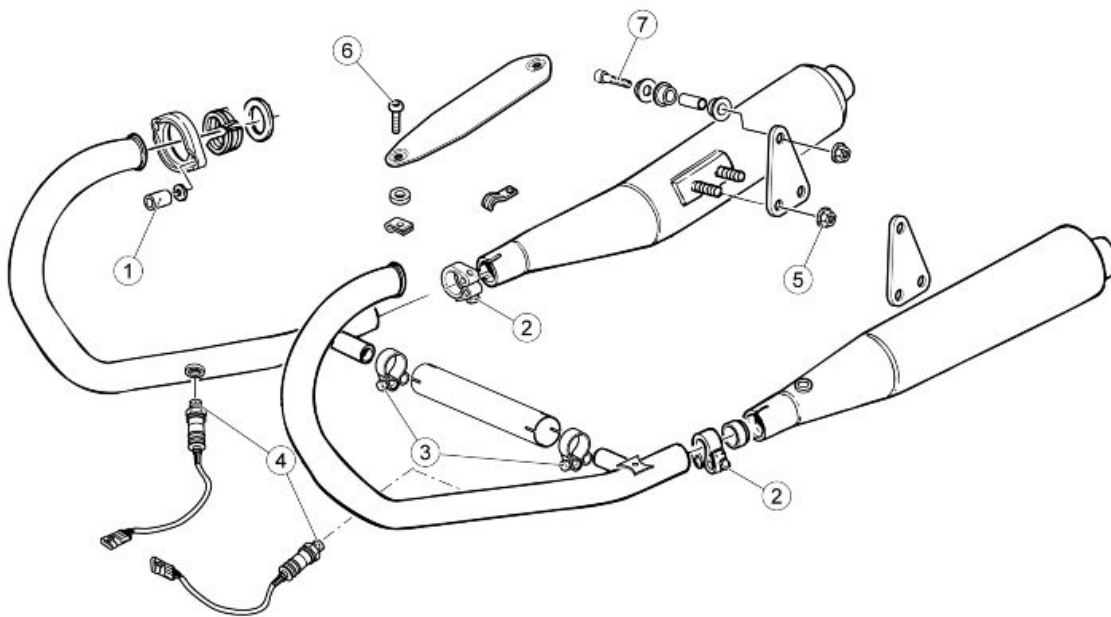

EXHAUST SYSTEM

Pos.	Description	Type	Quantity	Torque	Notes
1	Exhaust pipe fixing nut to the engine	M6	4	10 Nm (7.37 lb ft)	-
2	Exhaust pipe fixing clamp screw to the compensator	M6	1+1	10 Nm (7.37 lb ft)	-
3	Compensator fixing clamp screw to the silencer	M6	2	10 Nm (7.37 lb ft)	-
4	Lambda probe on compensator	M18x1.5	1	38 Nm (28.03 lb ft)	-
5	Nut fastening silencer to mounting plate	M8	4	25 Nm (18.44 lb ft)	-
6	Heat shield fixing screw	M6x12	6	10 Nm (7.37 lb ft)	Loctite 270
7	Screw fixing silencer mounting plate to frame	M8x40	2	25 Nm (18.44 lb ft)	-

Back side

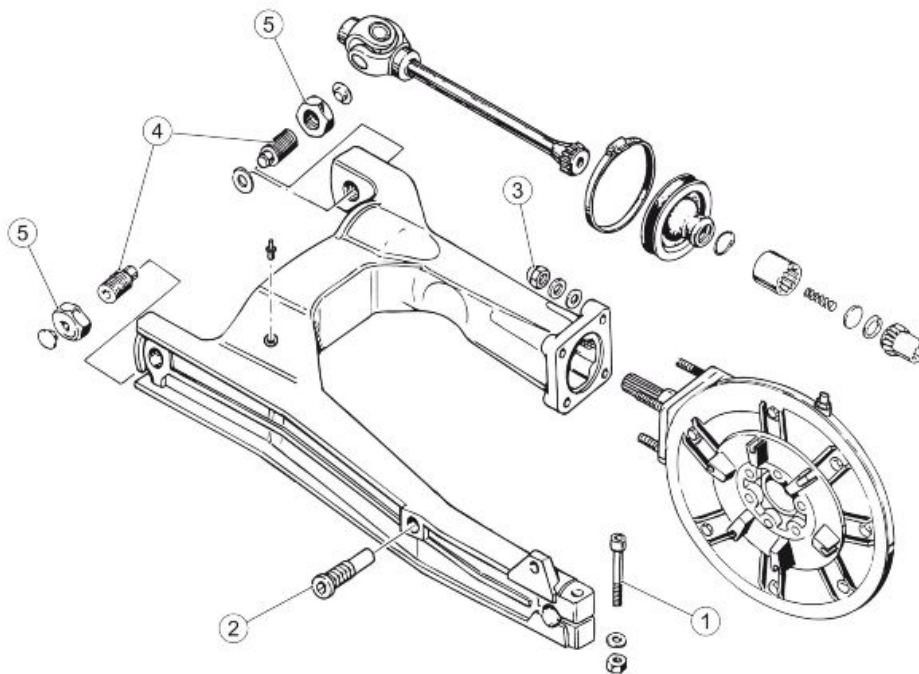

REAR TRANSMISSION - SWINGARM

pos.	Description	Type	Quantity	Torque	Notes
1	Swingarm clamp retaining screw	M10x45	1	30 Nm (22.13 lbf ft)	-
2	Pin fixing the rear calliper holding plate to swingarm	M16x1	1	25 Nm (18.44 lbf ft)	-
3	Nut fixing gearcase to swingarm	M8	4	25 Nm (18.44 lbf ft)	Hold the stud bolt
4	Pin fixing swingarm to gearbox	M20x1	2	-	Fully home with no preload
5	Lock nut on swingarm pin	M20x1	2	50 Nm (36.88 lbf ft)	Hold the pin

(V7 SPECIAL / V7 STONE)

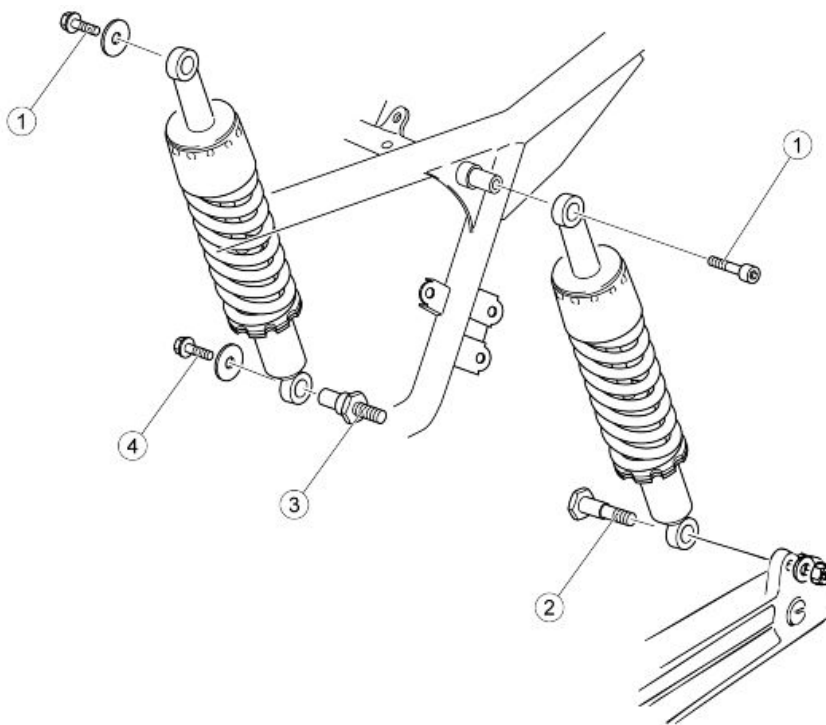

(V7 RACER)

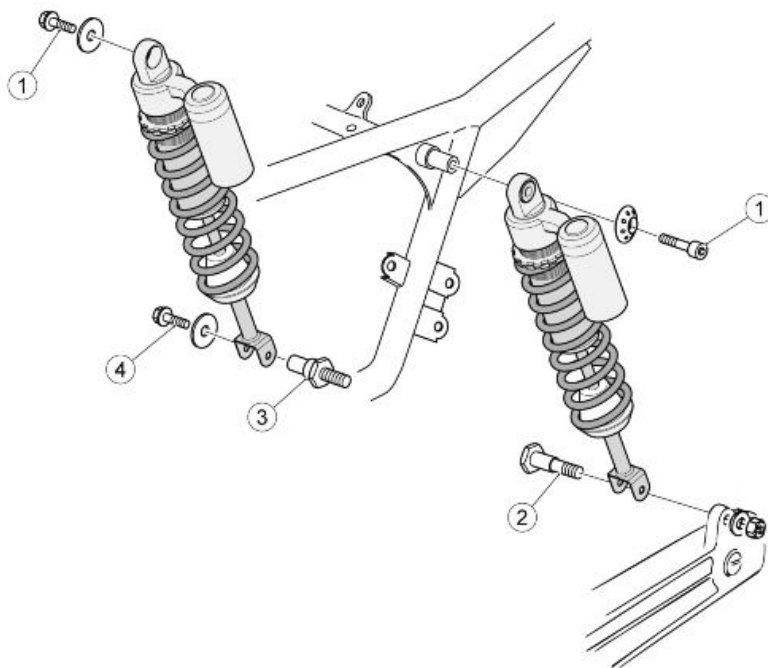

REAR SUSPENSION

pos.	Description	Type	Quantity	Torque	Notes
1	Upper screw fastening shock absorber to frame	M6x35	2	10 Nm (7.37 lbf ft)	Loctite 243
2	Lower pin fastening left shock absorber to swingarm	M10x1.5	1	35 Nm (25.81 lbf ft)	

pos.	Description	Type	Quantity	Torque	Notes
3	Stud bolt fixing right shock absorber to rear box	M12x1.5	1	35 Nm (25.81 lbf ft)	-
4	Screw fastening right shock absorber to stud bolt	M6x16	1	10 Nm (7.37 lbf ft)	Loctite 243

(V7 SPECIAL / V7 STONE)

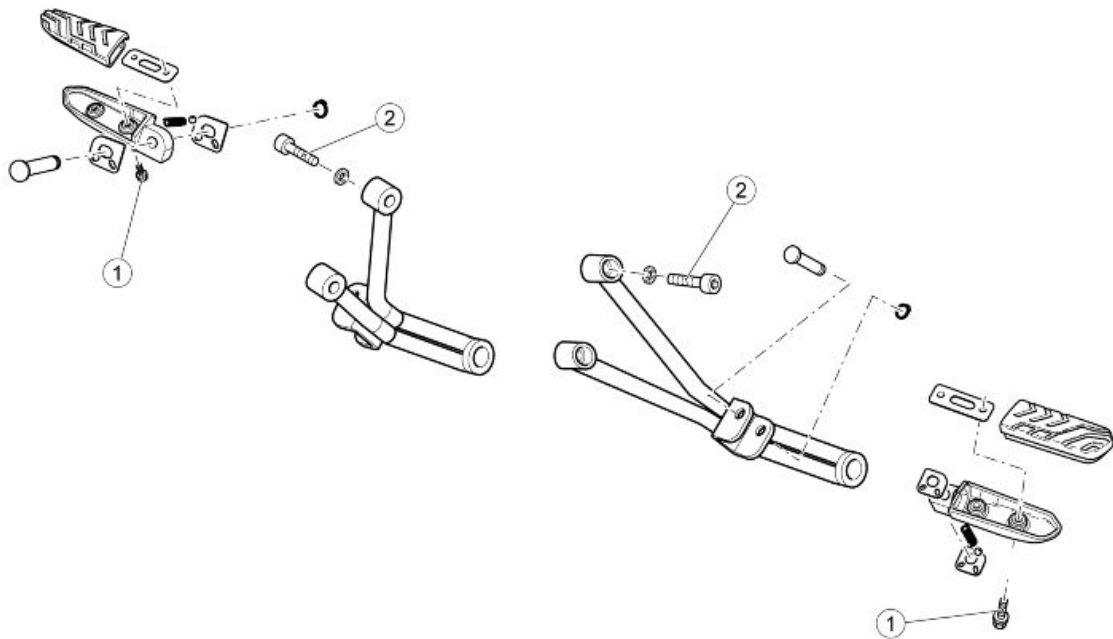

PASSENGER FOOTRESTS

pos.	Description	Type	Quantity	Torque	Notes
1	Pedal rubber fastening screw	M6x12	4	10 Nm (7.38 lb ft)	-
2	Screw fastening passenger footrest mounting to frame	M8	2+2	25 Nm (18.44 lb ft)	Loct. 243

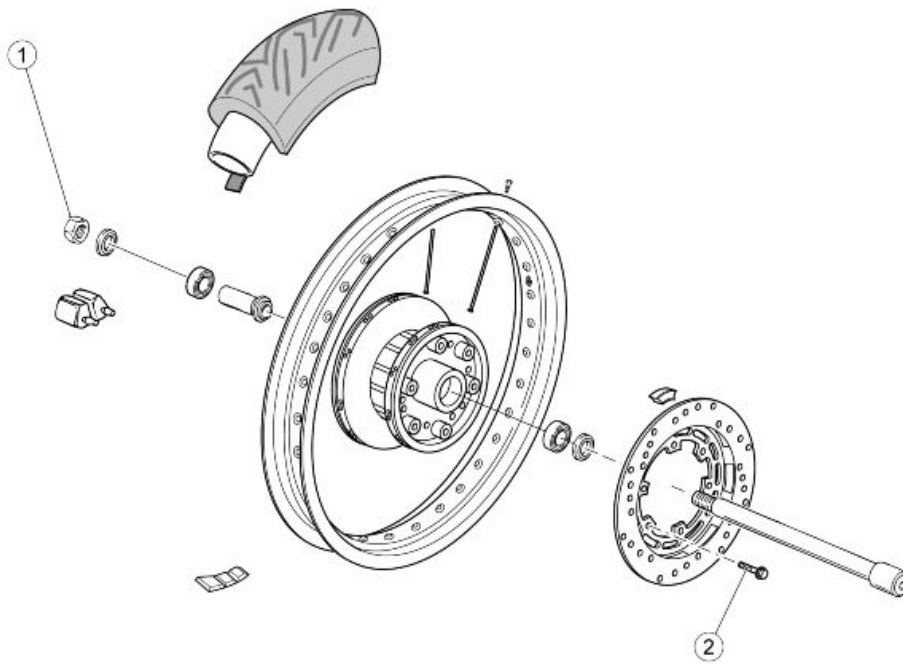

REAR WHEEL

pos.	Description	Type	Quantity	Torque	Notes
1	Rear wheel axle nut	M16x1.5	1	120 Nm (88.51 lb ft)	-
2	Rear brake disc fixing screw	M8x25	6	25 Nm (18.44 lb ft)	Loctite 243

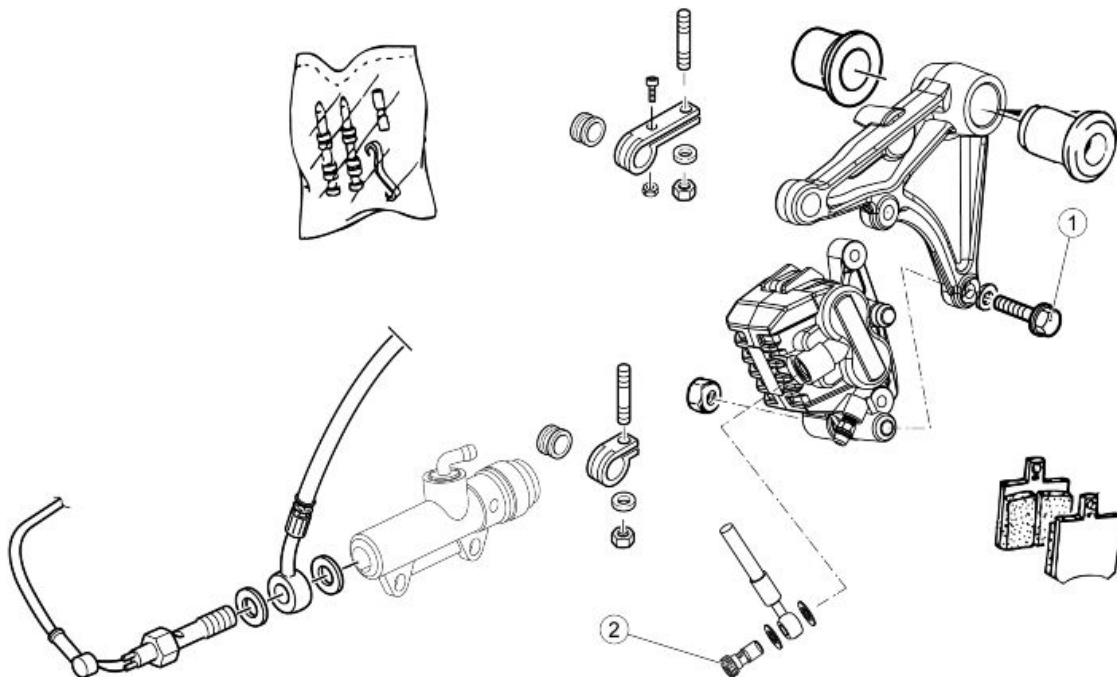

REAR BRAKE SYSTEM

pos.	Description	Type	Quantity	Torque	Notes
1	Rear brake calliper fixing screw	M8x30	2	25 Nm (18.44 lb ft)	-

pos.	Description	Type	Quantity	Torque	Notes
2	Drilled screw for brake pipe on caliper	-	1	25 Nm (18.44 lb ft)	-

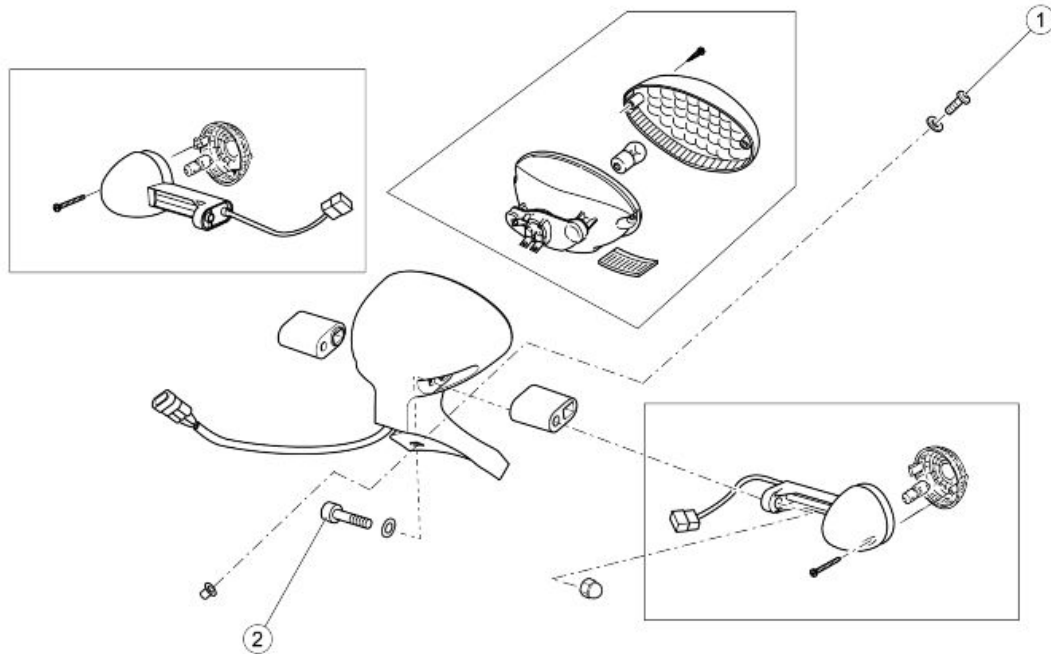

REAR LIGHTS

pos.	Description	Type	Quantity	Torque	Notes
1	Screw fastening taillight support to mudguard	M5x14	3	4 Nm (2.95 lbf ft)	-
2	Rear turn indicator fixing screw	M6	2	5 Nm (3.69 lbf ft)	-

(V7 RACER)

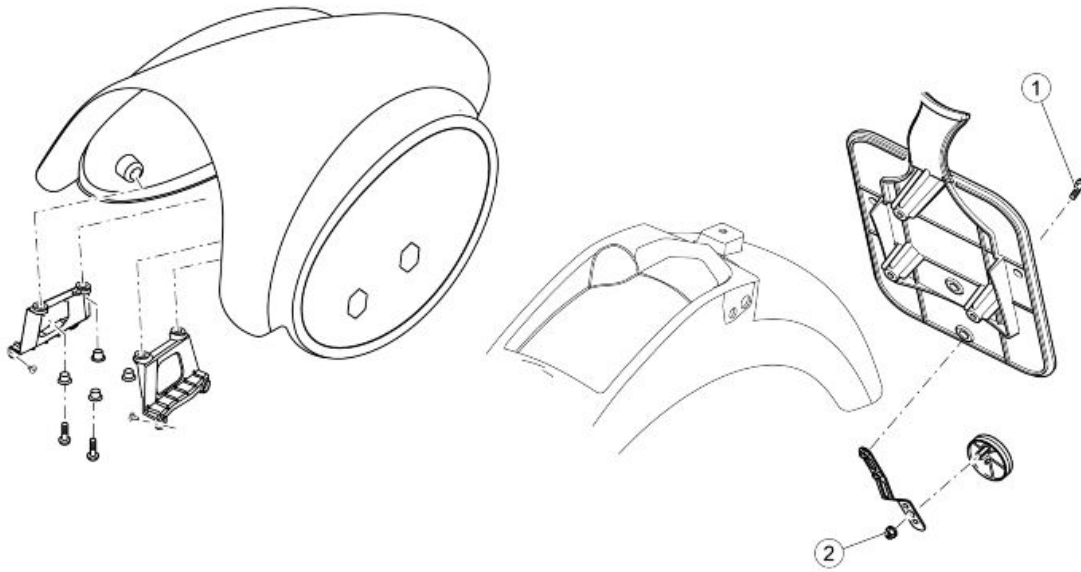

REAR SECTION BODYWORK - LICENSE PLATE MOUNTING

pos.	Description	Type	Quantity	Torque	Notes
1	Screw fastening retroreflector mounting to license plate mounting	M5x10	2	4 Nm (2.95 lbf ft)	-
2	Nut fixing retroreflector to mounting	M5	1	4 Nm (2.95 lbf ft)	-

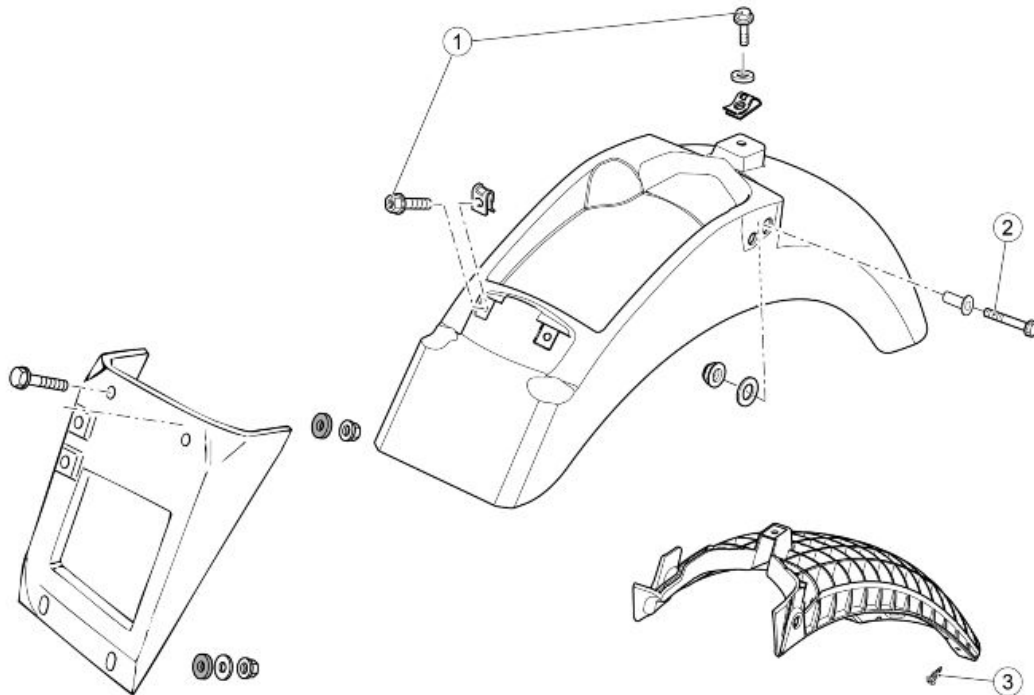

REAR MUDGUARD

pos.	Description	Type	Quantity	Torque	Notes
1	Rear mudguard front and central fixing screw	M6	2+1	10 Nm (7.37 lb ft)	
2	Rear mudguard side fixing screw	M8x30	2	25 Nm (18.44 lb ft)	
3	Screw fixing license plate holder to mudguard reinforcement	SWP M5x20	3	3 Nm (2.21 lb ft)	

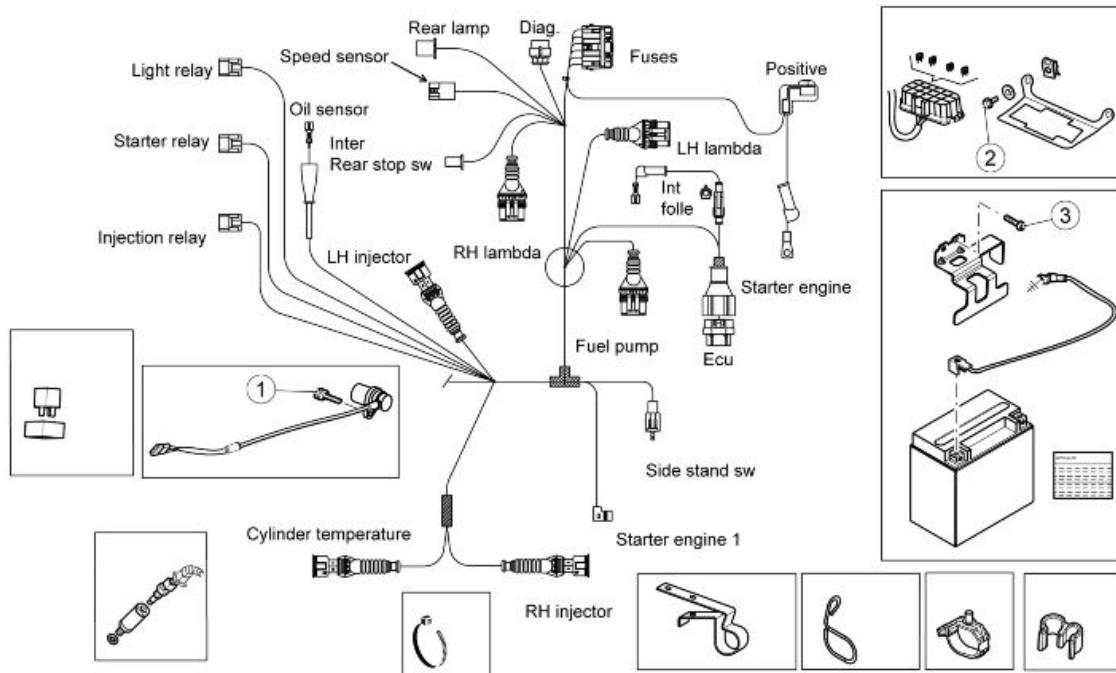

ELECTRICAL SYSTEM 01

pos.	Description	Type	Quantity	Torque	Notes
1	Speed sensor fastening screw	M6	1	10 Nm (7.37 lb ft)	
2	Fuse box bracket fixing screw	M5x12	2	4 Nm (2.95 lb ft)	-
3	Battery holder bracket fastening screw	M6	2	Manual	-

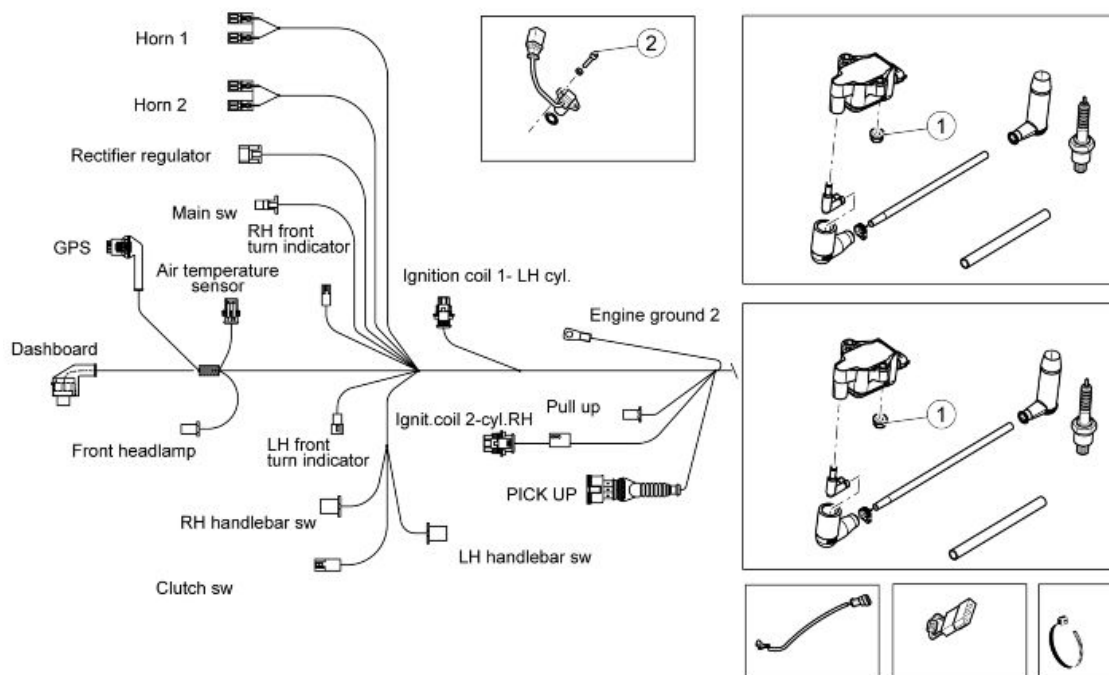

ELECTRICAL SYSTEM 02

pos.	Description	Type	Quantity	Torque	Notes
1	1 - Coil fixing nut	M6	2+2	10 Nm (7.37 lb ft)	-
2	2 - Timing sensor fastener screw	-	1	.. Nm (... lb ft)	-

Recommended products chart

RECOMMENDED PRODUCTS TABLE

Product	Description	Specifications
ENI i-RIDE PG 10W-60	Lubricant formulated with advanced synthetic technology and high performance additives to cater specifically for 4-stroke engines with high specific power outputs.	JASO MA, MA2 - API SG
AGIP GEAR MG SAE 85W-140	Transmission oil	API GL-4 and GL-5
AGIP GEAR MG/S SAE 85 W-90	Gearbox oil	API GL-5
AGIP FORK 7.5W	Fork oil	SAE 5W / SAE 20W
AGIP GREASE SM 2	Gray black smooth-textured lithium grease, containing molybdenum disulfide.	-
Neutral grease or petroleum jelly.	BATTERY POLES	
AGIP BRAKE 4	Brake fluid	SAE J 1703 - FMVSS 116 - DOT 3/4 - ISO 4925 - CUNA NC 956 DOT 4 synthetic fluid

NOTE





USE ONLY NEW BRAKE FLUID. DO NOT MIX DIFFERENT BRANDS OR TYPES OF OIL WITHOUT CHECKING THEIR BASE COMPATIBILITY.

INDEX OF TOPICS

SSPECIAL TOOLS

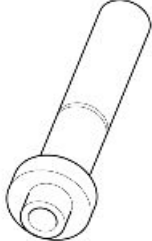
S-TOOLS

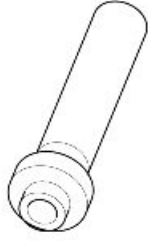
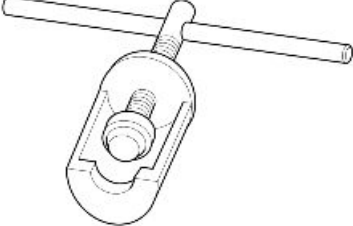
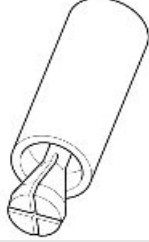
SPECIAL TOOLS

Stores code	Description	
19.92.61.00	Punch for seal ring of bevel gear set pinion	
19.92.88.00	Bevel gear set alignment pre-fitting tool	
19.92.60.00	Punch for gearcase sealing ring	
19.90.70.00	Extractor for internal ring on drilled bolt	
19.92.75.00	Extractor for external ring of gearcase bearing	
19.92.62.00	Punch for bearing on bevel gear set pinion	

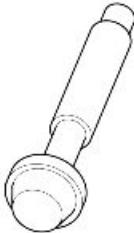
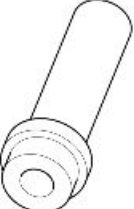
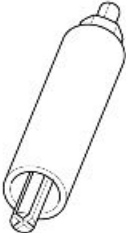
Stores code	Description	
19.92.64.00	Punch for external ring of tapered bearing on bevel gear set pinion holding body	
19.92.65.00	Punch for external ring of gearcase bearing	
19.92.76.00	Extractor for swinging arm holder bearing on gearbox cover	

INDEX OF TOPICS

MAINTENANCE

MAIN

Maintenance chart

NOTE

CARRY OUT MAINTENANCE OPERATIONS AT HALF THE INTERVALS SPECIFIED IF THE VEHICLE IS USED IN PARTICULAR RAINY OR DUSTY CONDITIONS, OFF ROAD OR FOR TRACK USE.

NOTE

THE TIMES LISTED ON THE SCHEDULED MAINTENANCE TABLE INCLUDE TIME DEDICATED TO MANAGEMENT ACTIVITIES.

I: INSPECT AND CLEAN, ADJUST, LUBRICATE OR REPLACE IF NECESSARY

V: CHECK AND CLEAN, ADJUST AND REPLACE IF NECESSARY

C: CLEAN, R: REPLACE, A: ADJUST, L: LUBRICATE

(1) Replace in case of leaks.

(2) Replace every 2 years or 20000 Km (12427 mi).

(3) Replace every 4 years.

(4) At each engine start.

(5) Check every month.

(6) Check every 3,000 km (1,864 mi)

(7) Check and clean and adjust or replace, if necessary, every 1,000 Km (621 mi)

ROUTINE MAINTENANCE TABLE

km x 1,000	1	10	20	30	40	50	60
Spark plugs		R	R	R	R	R	R
Transmission cables and controls	I	I	I	I	I	I	I
Steering bearings and steering clearance	I	I	I	I	I	I	I
Wheel bearings		I	I	I	I	I	I
Brake discs	I	I	I	I	I	I	I
Air filter		R	R	R	R	R	R
Engine oil filter	R	R	R	R	R	R	R
Lights operation / aiming		I	I	I	I	I	I
Vehicle general operation	I	I	I	I	I	I	I
Braking systems	I	I	I	I	I	I	I
Light circuit	I	I	I	I	I	I	I
Safety switches	I	I	I	I	I	I	I
Brake fluid (2)	I	I	I	I	I	I	I
Gearbox oil	R		R		R		R
Fork oil			R		R		R
Engine oil (6)	R	R	R	R	R	R	R
Final drive oil	R		R		R		R
Fork oil seal (1)	I		I		I		I
Tyres - pressure/wear (5)	I	I	I	I	I	I	I
Valve clearance adjustment	A	A	A	A	A	A	A
Wheels	I	I	I	I	I	I	I
Bolts and nuts tightening	I	I	I	I	I	I	I
Battery terminals tightening	I						
Head screws tightening	A						
Suspension and setting	I		I		I		I
Engine oil pressure warning light (4)							
Fuel lines (3)		I	I	I	I	I	I
Brake lines (3)		I	I	I	I	I	I
Clutch wear		I	I	I	I	I	I
Brake pad wear (7)	V	V	V	V	V	V	V
Labour time (minutes)	100	70	130	70	130	70	130

Transmission fluid

Check

- Keep the vehicle upright with both wheels on the ground.
- Unscrew and remove the cap/dipstick (1).
- The level is correct if the oil is close to the hole of the cap/dipstick (1).
- If the oil is lower than specified, top-up until it reaches the cap/dipstick hole (1).



CAUTION



DO NOT ADD ADDITIVES OR ANY OTHER SUBSTANCE TO THE FLUID. WHEN USING A FUNNEL OR ANY OTHER ELEMENT, MAKE SURE IT IS PERFECTLY CLEAN.

Replacement

CAUTION

THE UNIT MUST BE HOT WHEN THE OIL IS CHANGED AS UNDER SUCH CONDITIONS OIL IS FLUID AND THEREFORE EASY TO DRAIN.

NOTE

RIDE SOME km (miles) TO WARM UP ENGINE OIL

- Place a container with + 400 cm³ (25 cu in) capacity under the drainage plug (3).
- Unscrew and remove the drainage plug (3).
- Unscrew and remove the breather cap (2).
- Drain the oil into the container; allow several minutes for oil to drain out completely.
- Check and if necessary, replace the sealing washer of drainage plug (3).
- Remove any metal scrap attached to the drainage plug (3) magnet.
- Screw and tighten the drainage plug (3).
- Pour new oil through the fill opening (1) until it reaches the cap/dipstick hole (1).

CAUTION

DO NOT ADD ADDITIVES OR ANY OTHER SUBSTANCE TO THE FLUID. WHEN USING A FUNNEL OR ANY OTHER ELEMENT, MAKE SURE IT IS PERFECTLY CLEAN.

- Screw and tighten the caps (1 - 2).



Engine oil

Check

CAUTION

ENGINE MUST BE WARM TO CHECK ENGINE OIL LEVEL

NOTE

DO NOT LET THE ENGINE IDLE WITH THE VEHICLE AT STANDSTILL TO WARM UP THE ENGINE AND REACH THE OPERATING TEMPERATURE OF ENGINE OIL. OIL IS BEST CHECKED AFTER RUNNING FOR ABOUT 15 KM (10 miles).

- Switch off the engine and wait at least five minutes to allow the lubricant to drain back into the sump.
- Keep the vehicle upright with both wheels on the ground.
- Unscrew and remove the cap with dipstick.
- Clean dipstick.
- Refit the cap with dipstick into its hole without tightening.
- Remove the cap with dipstick.
- Check oil level by means of the oil dipstick.
- The oil level is correct when it close to the "MAX" mark.

MAX = maximum level

MIN = minimum level

Add engine oil if required:

- Unscrew and remove the cap with dipstick.
- Top-up with engine oil until it goes above the minimum level marked "MIN".

CAUTION

DO NOT ADD ADDITIVES OR ANY OTHER SUBSTANCE TO THE OIL. WHEN USING A FUNNEL OR ANY OTHER ELEMENT, MAKE SURE IT IS PERFECTLY CLEAN.

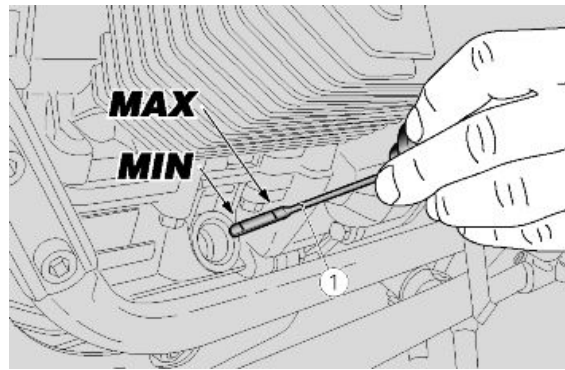

Replacement

- Place a container with + 2000 cm³ (122 cu.in) capacity under the drainage plugs (1).
- Unscrew and remove the drainage plugs (1).
- Unscrew and remove the filler cap (2).
- Drain the oil into the container; allow several minutes for oil to drain out completely.
- Check and if necessary, replace the sealing washers of drainage plugs (1).
- Remove any metal scrap attached to the magnet of drainage plugs (1).
- Screw and tighten the drainage plugs (1).

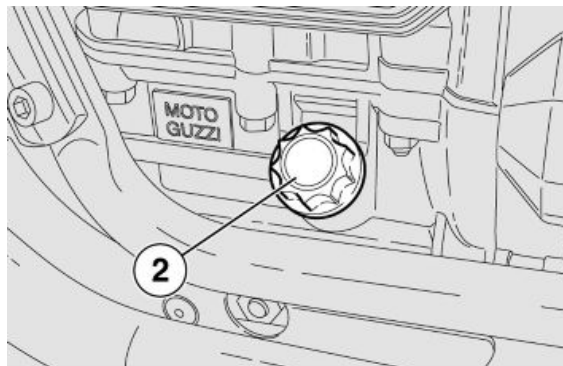
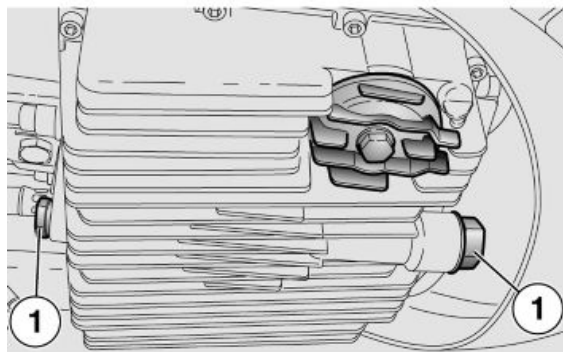

**Drainage plugs tightening torque (1): 12 Nm
(1.2 kgm)**



DO NOT DISPOSE OF OIL INTO THE ENVIRONMENT. DISPOSE OF ENGINE OIL IN A SEALED CONTAINER AND TAKE IT TO YOUR SUPPLIER OR TO THE NEAREST USED OIL COLLECTION CENTRE.

Engine oil filter

- Loosen the screw (3) and remove the cover (4).
- Remove the engine oil filter (5).

NOTE

NEVER REUSE AN OLD FILTER.

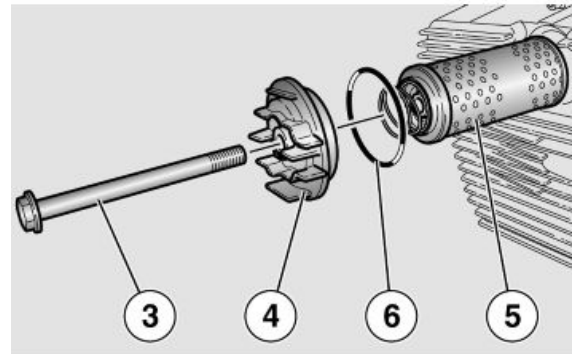

- Spread a thin layer of oil on the sealing ring (6) of the new engine oil filter.
- Fit the new engine oil filter with the spring facing downwards.
- Refit the cover (4), screw and tighten the screw (3)

Air filter

- Remove the saddle
- Unhook the connector from the air-box cover
- Remove the air-box cover fixing screw

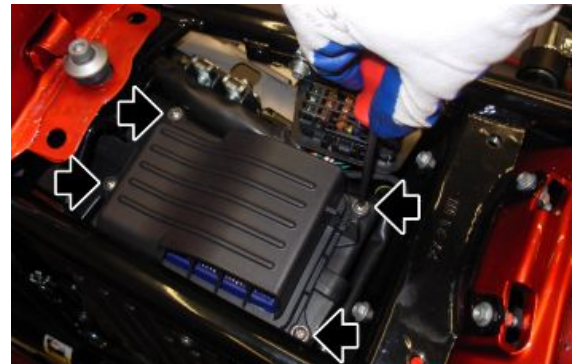

- Remove the air-box cover
- Extract the air filter



Throttle body removal

- Loosen the clamps that secure the sleeve to the intake manifolds



- Remove the sleeve



- Remove the battery
- Remove the MIU G3 control unit connector support bracket fixing screw



- Disconnect the MIU G3 control unit connector



- Unscrew the clamp that secures the throttle body to the filter box
- Extract the throttle body laterally

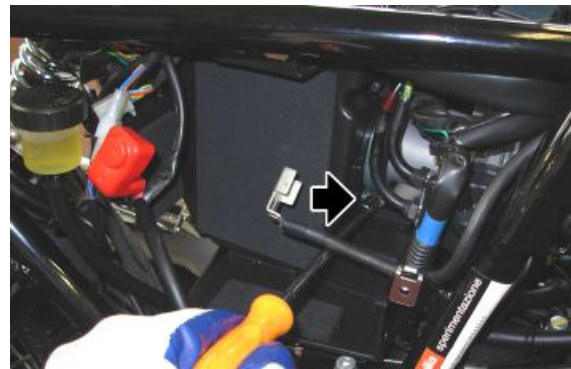

- Remove the throttle body guard

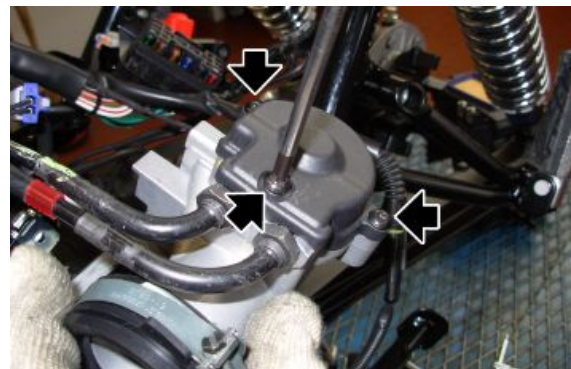

- Loosen the gas cables fixing nuts on the throttle body and unhook them

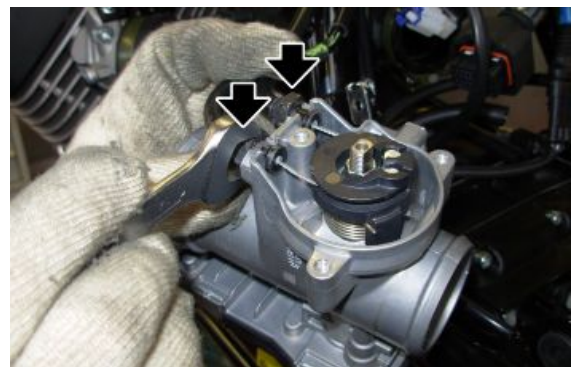

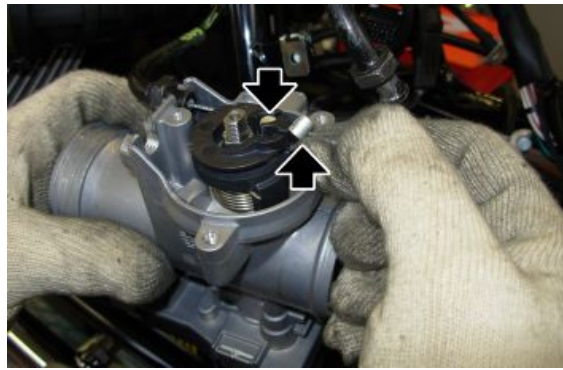

- Remove the throttle body

Throttle body installation

- Connect the gas cables on the throttle body

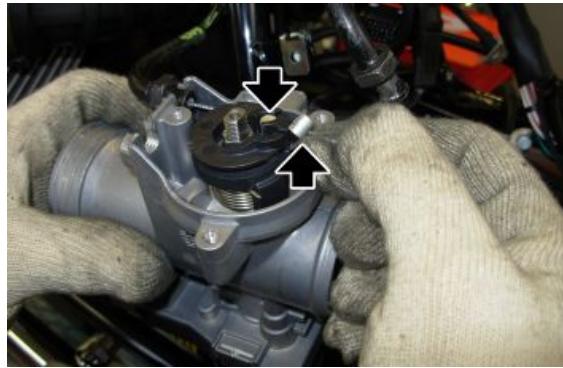

- Correctly position the guides and tighten the nuts, checking correct operation of the throttle grip

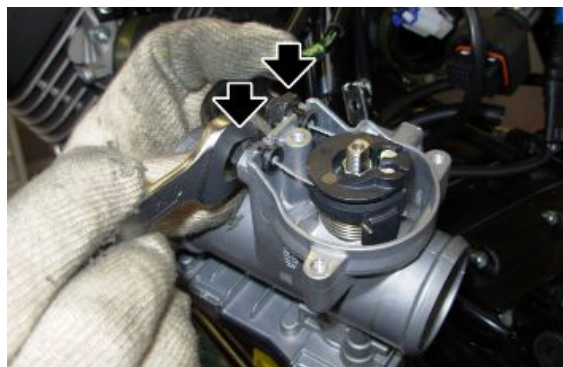

- Install the throttle body guard

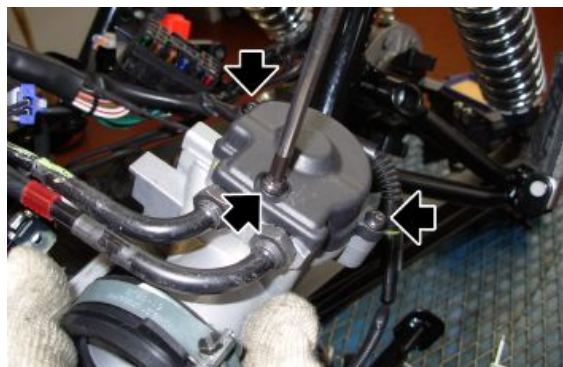

- Insert the throttle body in the sleeve and tighten the clamp to secure it

CAUTION

TAKE PARTICULAR CARE THAT THE CLAMP IS POSITIONED CORRECTLY. INCORRECT POSITIONING WILL CAUSE VEHICLE MALFUNCTIONS

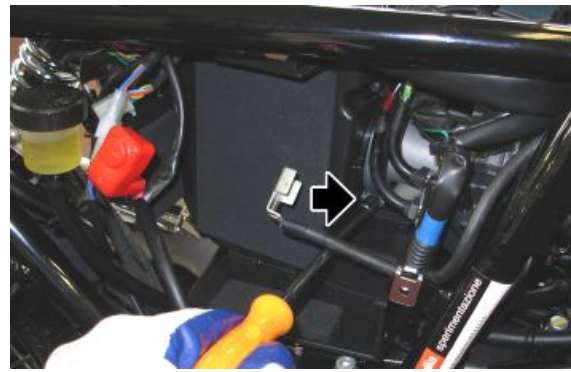

- Connect the MIU G3 control unit connector



- Install the MIU G3 control unit connector support bracket



- Install the sleeve, taking care that they are inserted correctly



- Tighten the clamps, checking correct positioning

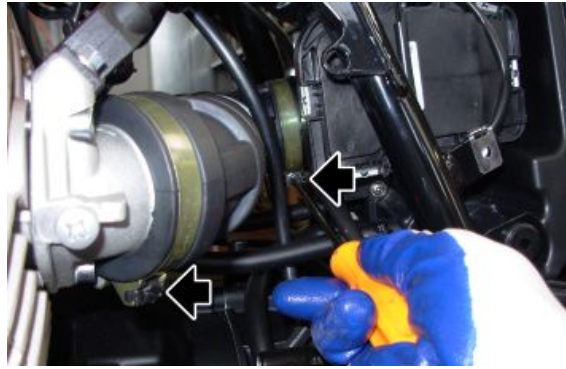

Air filter housing

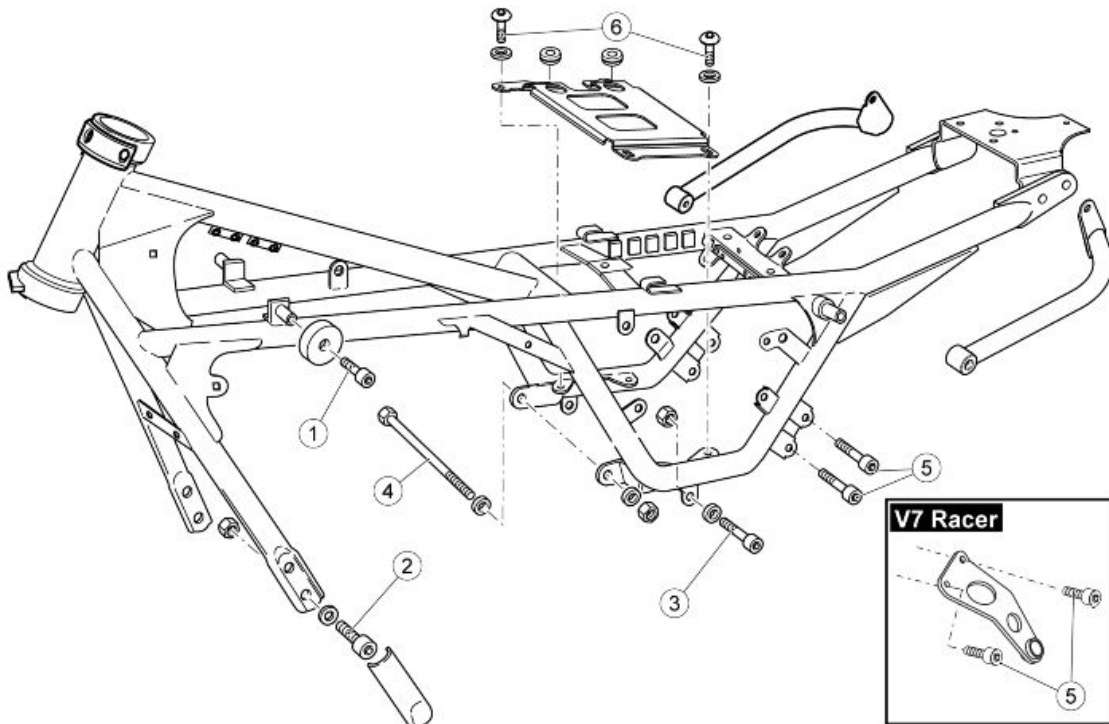

FRAME

pos.	Description	Type	Quantity	Torque	Notes
1	Screw fixing tank mounting rubber blocks to frame	M8x14	2	25 Nm (18.44 lbf ft)	-
2	Cradle front fixing screw	M10x30	4	50 Nm (36.88 lbf ft)	-

pos.	Description	Type	Quantity	Torque	Notes
3	Screw fastening gearbox to frame	M10x55	2	50 Nm (36.88 lbf ft)	-
4	Pin fixing engine/gearbox to chassis	M10x205	1	50 Nm (36.88 lbf ft)	-
5	Screw fixing exhaust silencer mounting to frame	M8x16	4	25 Nm (18.44 lbf ft)	Loctite 243
6	Battery supporting plate fixing screw	M8x16	4	25 Nm (18.44 lbf ft)	-

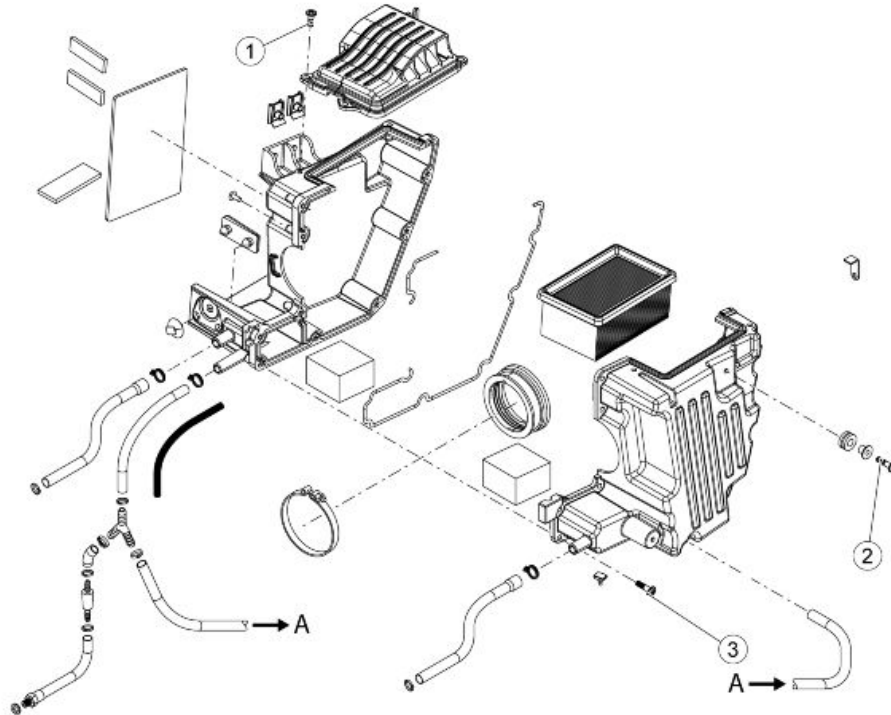

TIGHTENING TORQUE - CENTRAL PART - FILTER BOX

pos.	Description	Type	Quantity	Torque	Notes
1	Air filter box cover fastening screw	SWP 5x14	4	3 Nm (2.21 lb ft)	-
2	Air filter box fastening screw to frame	SWP 5x20	2	3 Nm (2.21 lb ft)	-
3	Air filter box fastening screw	SWP 5x20	9	3 Nm (2.21 lb ft)	-

Air filter housing removal

- Remove the saddle and the side fairings
- Remove the battery
- Remove the rear wheel.
- Remove the splash guard
- Remove the fuse box support fixing screws (1)

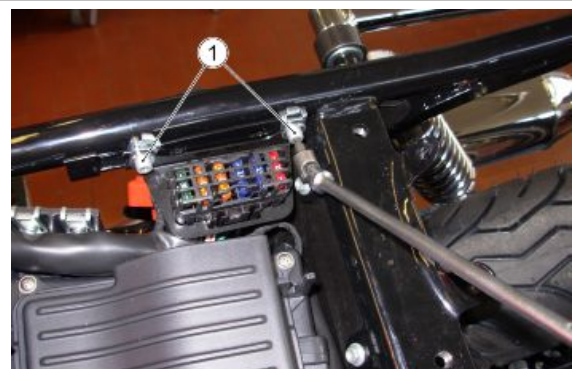

- Move the filter box to the side enough to allow removal of the fixing screws (2) on the left side of the filter box support.



See also

[Side body panels](#)
[Splash guard](#)
[Removing](#)
[Specific operations for the vehicle](#)

- Move the filter box to the side enough to allow removal of the fixing screws (3) on the right side of the filter box support.

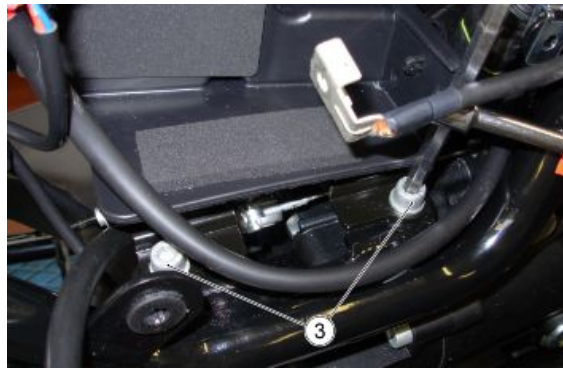

- Disconnect the neutral switch connector
- Lift the air filter box enough to allow the support plate to be removed, sliding out neutral switch cabling



- Unscrew the clamp that fastens the throttle body to the air filter box

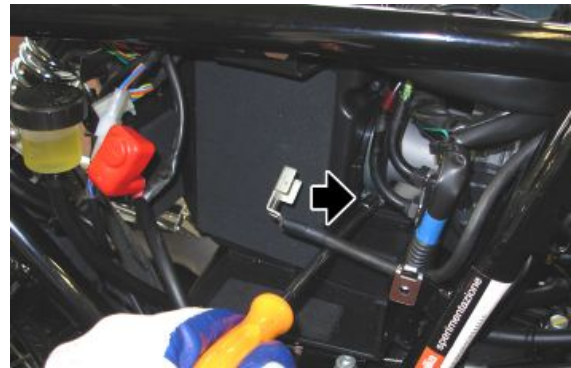

- Disconnect the blow-by and breather tubes



- Remove the air-box cover

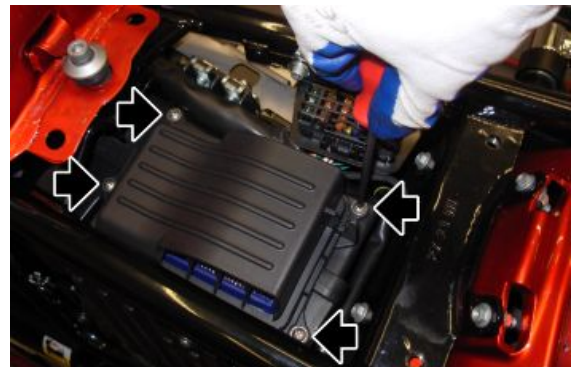

- Remove sliding the complete filter box out toward the rear

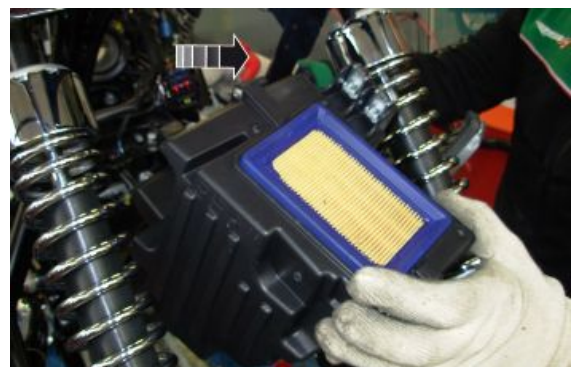

Air filter housing installation

- Insert the filter box from the rear

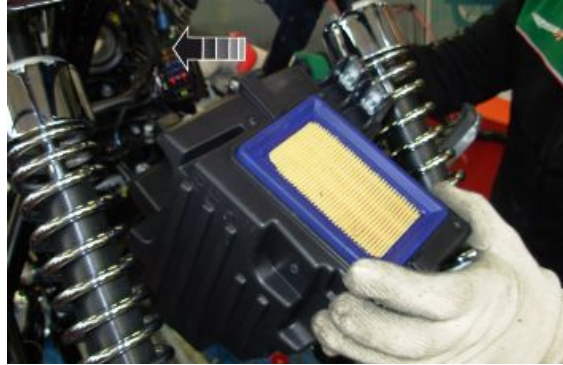

- Insert the throttle body in the sleeve and tighten the clamp to secure it

CAUTION

TAKE PARTICULAR CARE THAT THE CLAMP IS POSITIONED CORRECTLY. INCORRECT POSITIONING WILL CAUSE VEHICLE MALFUNCTIONS



- Install the air-box cover

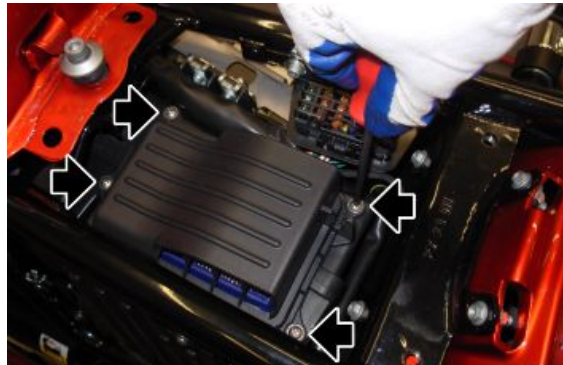

- Connect the blow-by and breather tubes



- Position the air filter box support, taking care to pass the neutral switch cabling through the hole



- Move the filter box to the side enough to allow tightening of the fixing screws (3) on the right side of the filter box support.

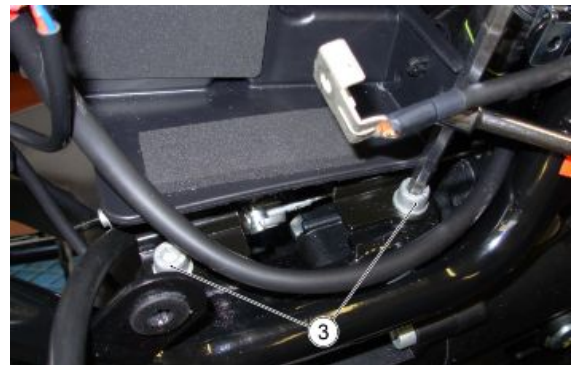

- Move the filter box to the side enough to allow tightening of the fixing screws (2) on the left side of the filter box support.



- Correctly position the air filter box on the support
- Fix the screws (1) of the fuse box support

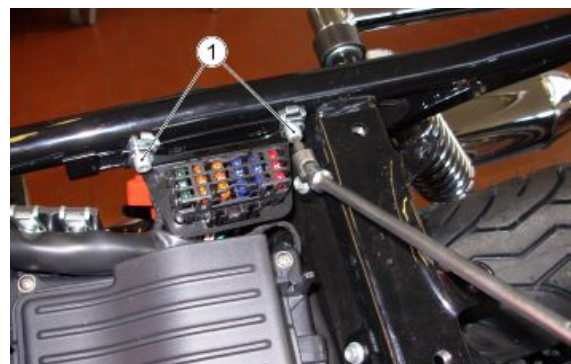

Braking system

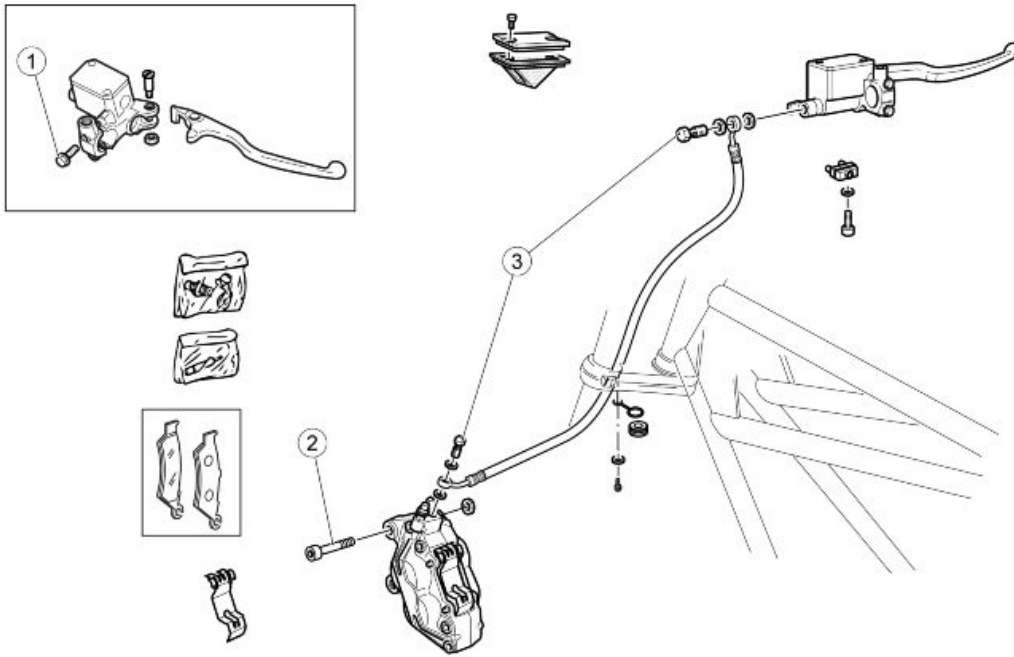

FRONT BRAKE SYSTEM

pos.	Description	Type	Quantity	Torque	Notes
1	Screw fastening the brake pump U-bolt to the semi-handlebar	M6	2	10 Nm (7.37 lbf ft)	Tighten using a 1-2-1 sequence
2	Front brake calliper fixing screw	M10x30	2	50 Nm (36.88 lb ft)	-
3	Drilled screw for brake fluid pipe on pump and calliper	-	2	25 Nm (18.44 lb ft)	-

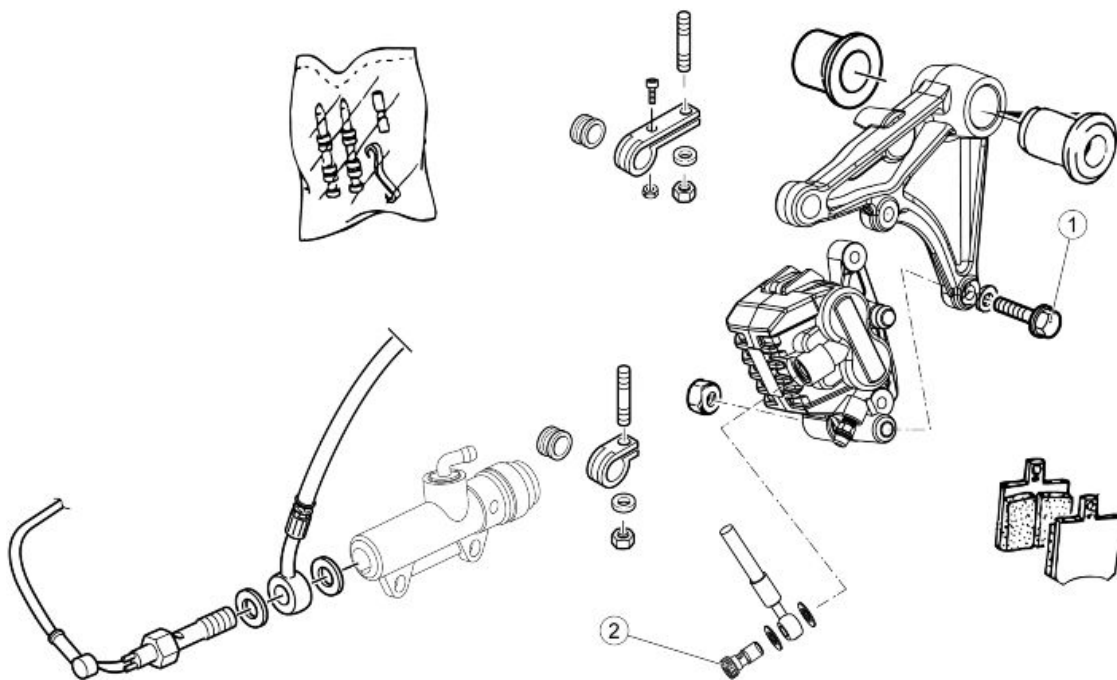

REAR BRAKE SYSTEM

pos.	Description	Type	Quantity	Torque	Notes
1	Rear brake calliper fixing screw	M8x30	2	25 Nm (18.44 lb ft)	-
2	Drilled screw for brake pipe on calliper	-	1	25 Nm (18.44 lb ft)	-

Level check**Brake fluid check**

- Rest the vehicle on its stand.
- For the front brake, turn the handlebar fully to the right.
- For the rear brake, keep the vehicle upright so that the fluid in the reservoir is at the same level with the plug.
- Make sure that the fluid level in the reservoir is above the "MIN" reference mark:

MIN = minimum level

MAX = maximum level

If the fluid does not reach at least the "**MIN**" reference mark:

- Check brake pads and disc for wear.
- If the pads and/or the disc do not need replacing, top-up the fluid.

Top-up

Front brake:

- Unscrew the two screws (1) of the brake fluid reservoir (2) using a Phillips screwdriver.
- Lift and remove the cover (3) and screws (1) as well.
- Remove the gasket (4).

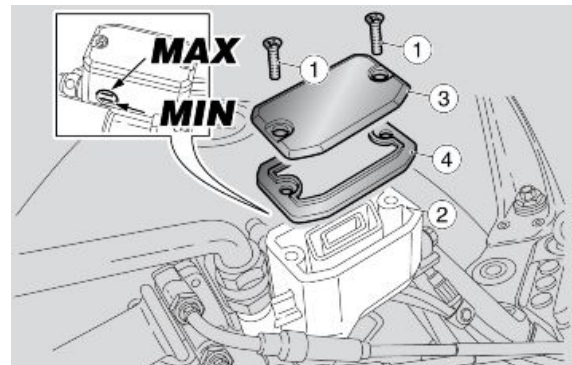

Rear brake:

- Unscrew and remove the cap (5).
- Remove the gasket (6).
- Top-up the reservoir with brake fluid to the correct level, which is between the two "MIN" and "MAX" reference marks.

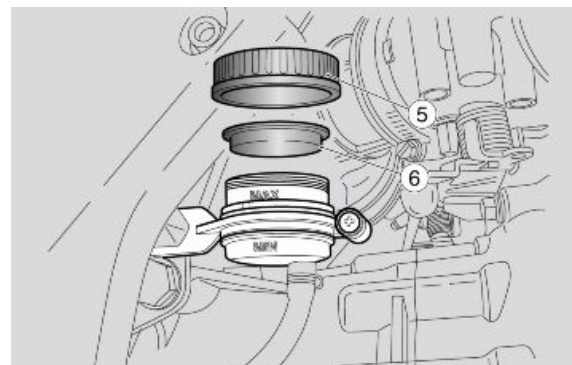

RISK OF BRAKE FLUID SPILLS. DO NOT OPERATE THE BRAKE LEVER WITH BRAKE FLUID RESERVOIR CAP LOOSENED OR REMOVED.

CAUTION



AVOID PROLONGED AIR EXPOSURE OF THE BRAKE FLUID. BRAKE FLUID IS HYGROSCOPIC AND ABSORBS MOISTURE WHEN IN CONTACT WITH AIR. LEAVE THE BRAKE FLUID RESERVOIR OPEN ONLY FOR THE TIME NEEDED TO COMPLETE THE TOPPING UP PROCEDURE.



TO AVOID SPILLING FLUID WHILE TOPPING-UP, KEEP THE TANK PARALLEL TO THE RESERVOIR EDGE (IN HORIZONTAL POSITION).

DO NOT ADD ADDITIVES OR OTHER SUBSTANCES TO THE FLUID.

WHEN USING A FUNNEL OR ANY OTHER ELEMENT, MAKE SURE IT IS PERFECTLY CLEAN.



DO NOT EXCEED THE "MAX" LEVEL MARK WHEN TOPPING UP.

TOP-UP TO "MAX" LEVEL MARK ONLY WHEN BRAKE PADS ARE NEW. WHEN TOPPING UP DO NOT EXCEED THE "MAX" LEVEL MARK WHEN BRAKE PADS ARE WORN AS YOU RISK SPILLING FLUID WHEN CHANGING THE BRAKE PADS.

CHECK BRAKING EFFICIENCY. IN CASE OF EXCESSIVE TRAVEL OF THE BRAKE LEVER OR POOR PERFORMANCE OF THE BRAKING SYSTEM, TAKE YOUR VEHICLE TO AN Official Moto Guzzi Dealer, AS IT MAY BE NECESSARY TO PURGE THE AIR IN THE SYSTEM.

INDEX OF TOPICS

ELECTRICAL SYSTEM

ELE SYS

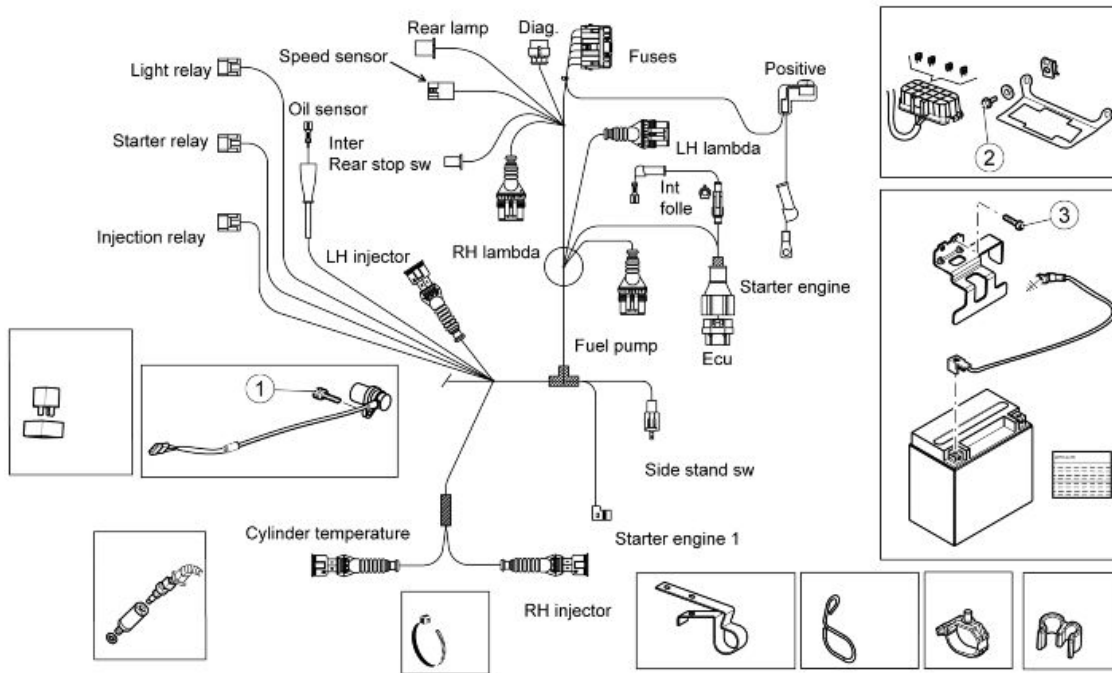

ELECTRICAL SYSTEM 01

pos.	Description	Type	Quantity	Torque	Notes
1	Speed sensor fastening screw	M6	1	10 Nm (7.37 lb ft)	-
2	Fuse box bracket fixing screw	M5x12	2	4 Nm (2.95 lb ft)	-
3	Battery holder bracket fastening screw	M6	2	Manual	-

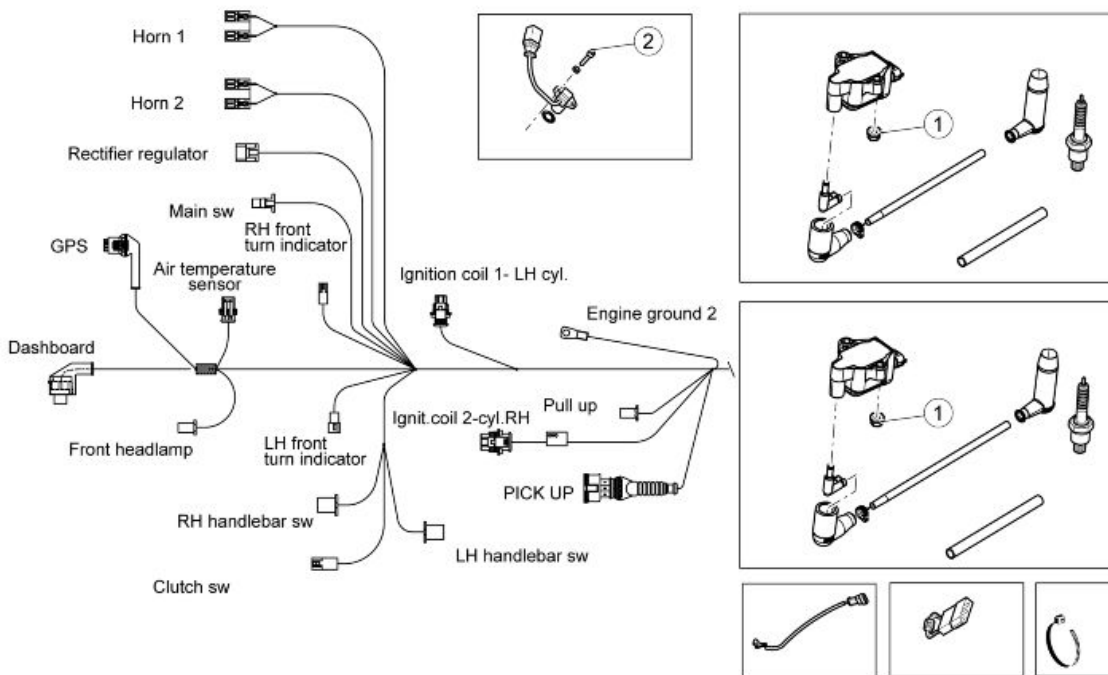

ELECTRICAL SYSTEM 02

pos.	Description	Type	Quantity	Torque	Notes
1	1 - Coil fixing nut	M6	2+2	10 Nm (7.37 lb ft)	-

pos.	Description	Type	Quantity	Torque	Notes
2	2 - Timing sensor fastener screw	-	1	.. Nm (... lb ft)	-

Components arrangement

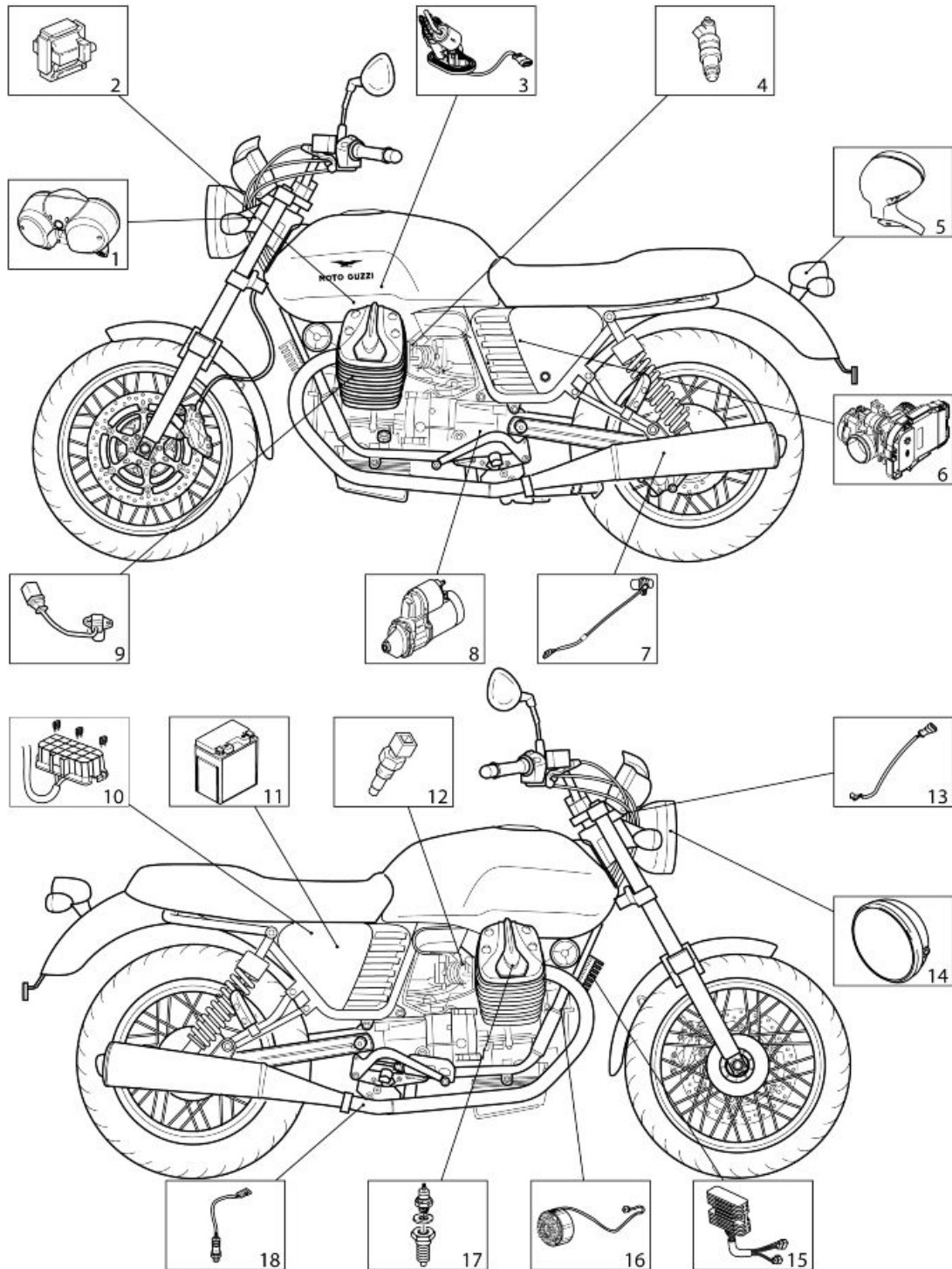

key:

- 1. Instrument panel
- 2. Coil

3. Fuel pump
4. Injector
5. Taillight
6. MIU G3 Control Unit
7. Speed sensor
8. Starter motor
9. Engine speed sensor
10. Fuses
11. Battery
12. Head temperature sensor
13. Instrument panel air sensor
14. Headlamp
15. Voltage regulator
16. Alternator
17. Oil pressure sensor
18. Lambda probes

Electrical system installation

INTRODUCTION

Scope and applicability

The position of the cable harnesses, how they are fixed to the motorcycle and potential problems are defined on the following sections in order to reach the objectives of vehicle reliability.

Materials used and corresponding quantities

The electrical system consists of the following cable harnesses and parts:

- 1 Main Cable Harness
- 1 Ground cable Negative - Engine
- 1 Left H.V. Cable
- 1 Left H.V. Cable Sheath (Grey)
- 1 Right H.V. Cable
- 1 Right H.V. Cable Sheath (Black)
- 3 Relays 12V 30A
- 1 Pull Up Module (resistance-diode)
- 1 Stand switch
- 2 Lambda probes
- 2 NGK Plug Caps

Small parts and mountings

- 2 Large black clamps 290x4.5

- 10 Medium black clamps 190x4.5
- 5 Small black 160x2.5 clamps
- 1 Cable guides
- 3 Cable grommet (there are various types of cable grommets)
- 2 Profile guards (140mm long)
- 1 Miu3 bracket
- 1 Tcei M8x40 screw
- 1 Black sheath D16 S0.4
- 3 Cable guides (there are various types of cable guides)

Motorcycle division

The wiring timing is subdivided in three essential sections, as indicated in the figure.

1. Front section
2. Central section
3. Rear part
4. ENGINE



SPECIAL CHECKS FOR THE CORRECT CONNECTION AND LAYING OF CABLES

It is extremely important that any security-locks for the following connectors are properly connected and correctly tightened to ensure proper engine, and therefore proper vehicle, operation.

Carry out the checks listed below.

1. Check control unit connection and correct insertion of the relative rubber plug.
2. Check the correct fastening of metallic bracket screw on the throttle body.
3. Check the right and left injectors connection.
4. Check the water temperature sensor connection (Blue connector).
5. Check correct insertion of H.V. Cables with Coils.
6. Check whether the Grey H.V. Cable connects on the Coil with the Grey tape.
7. Check whether the Grey H.V. Cable goes to the Left engine head.
8. Check the Coils connection.
9. Check correct insertion of the engine oil hood and the presence of the clamp.
10. Check ground fastening on the engine, starter motor positive and relative hood.
11. Check NEUTRAL cable fastening.
12. Check whether the right lambda probe is connected to the output labelled "LAMBDA DX" (RH LAMBDA).
13. Check Regulator and Flywheel connection.
14. Check whether the right lambda probe is inserted on the cable grommet under the clutch housing.
15. Check right and left Lambda connections.

16. Check the presence of the Pull Up module and the presence of the black hose under the transparent one.
17. Check the Pick Up connection.
18. Check correct insertion of the starter motor hood
19. Check the presence of the Red protective hood on the battery Positive.
20. Check that the stand switch connector is blue and clamped.
21. Check the side stand connection and left lambda.
22. Check that the H.V. cables are connected well to with the NGK plug caps.
23. Check the stand switch cable ties on the frame under the vehicle
 - THE CIRCLED CONNECTORS ARE DEEMED MORE CRITICAL THAN THE OTHERS BECAUSE DISCONNECTION OF THESE MAY CAUSE THE VEHICLE TO STOP.
 - Undoubtedly the connection of the rest of connectors is also important and essential for the correct operation of the vehicle.

Front side

CAUTION

ONCE THE ELECTRICAL SYSTEM IS REFITTED, THE CONNECTORS RECONNECTED AND CLAMPS AND RETAINERS RESTORED, CARRY OUT THE CHECKS INDICATED UNDER "SPECIAL CHECKS FOR THE CORRECT CONNECTION AND LAYING OF CABLES" IN THE "ELECTRICAL SYSTEM INSTALLATION" SECTION.

(V7 SPECIAL / V7 STONE)

TABLE A

1. Main cable harness
2. Clamp that secures the main cabling to the headlamp support plate
3. Ambient temperature sensor
4. Clamp that secures the ambient temperature sensor to the front headlamp support plate
5. GPS wiring connector
6. Front headlamp connector

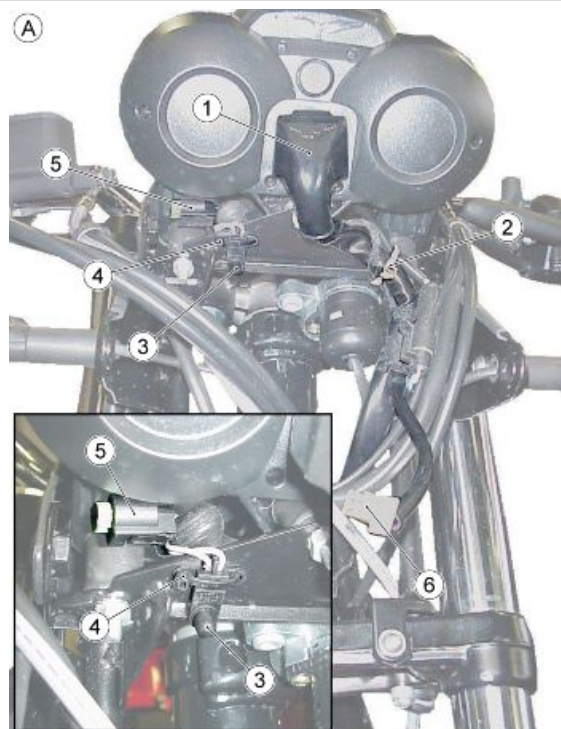

(V7 RACER)

TABLE A1

1. Main cable harness
2. Clamp that secures the main cabling to the headlamp support plate
3. Ambient temperature sensor
4. Clamp that secures the ambient temperature sensor to the front headlamp support plate
5. GPS wiring connector



TABLE B

1. Voltage regulator connector
 2. Profile guards
 3. Key connector
 4. Left turn indicator connector
 5. Flywheel connector
- If deemed necessary, the voltage regulator connector (1) and the flywheel (2) can be tightened with a clamp in order to avoid them disconnecting.

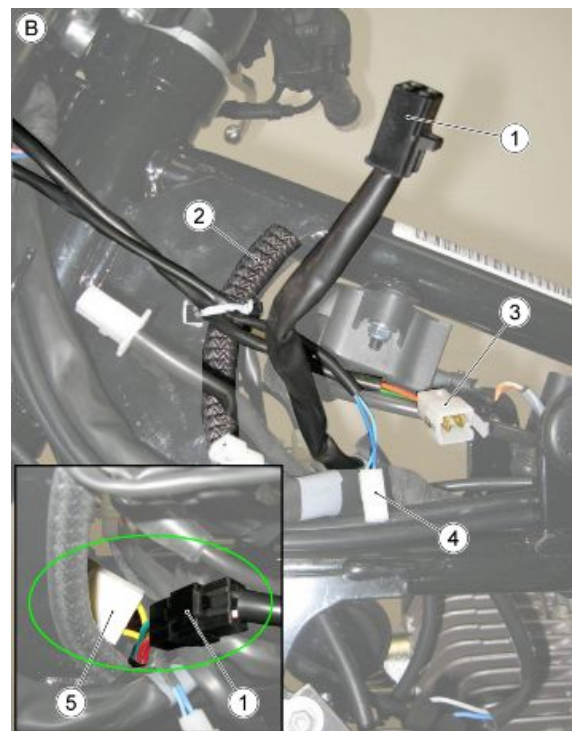
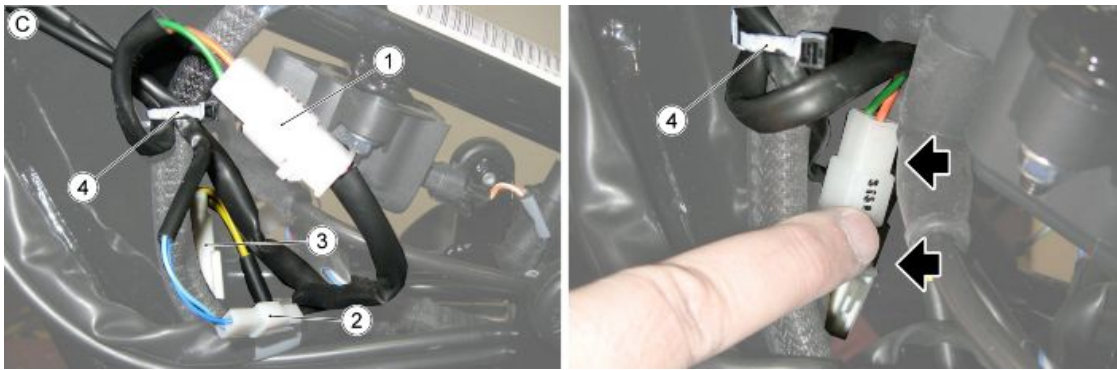
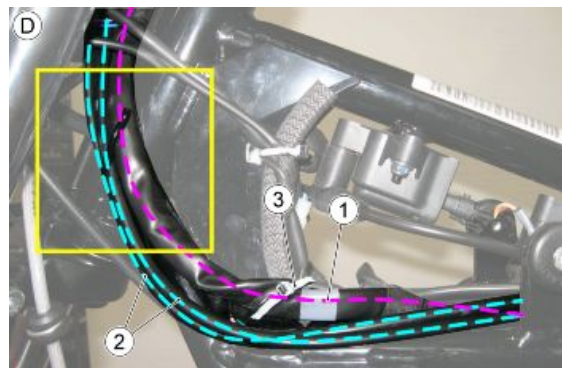

TABLE C

1. Key connector
 2. Left turn indicator connector
- Both connectors, once connected, are positioned behind the steering tube.

**TABLE D**

1. Main cable harness
2. Gas cables
3. Cable tie that secures the main cabling to the frame in correspondence to the grey taping
 - The gas cables must pass under the main cabling.

**TABLE E**

1. Left light switch connector
2. Right turn indicator connector
3. Clutch switch connector
4. Right light switch connector
5. Cable tie that secures the cabling in correspondence to the grey tapings
6. Profile guards

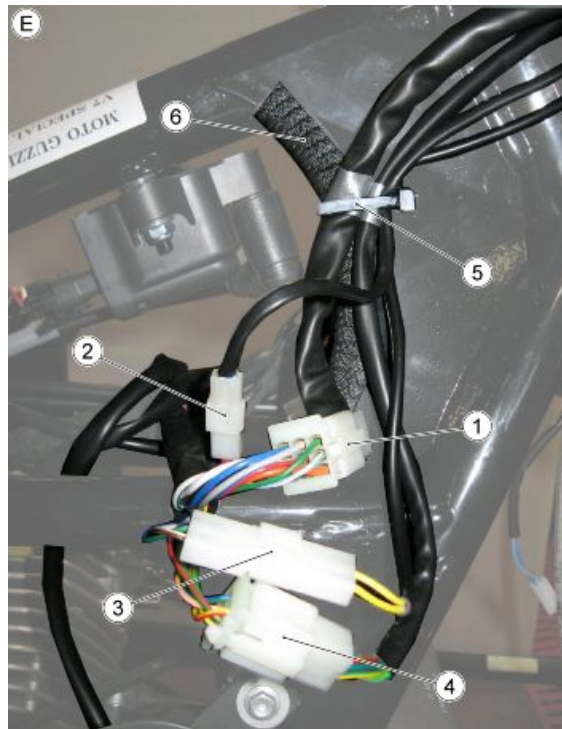
**TABLE F**

- Pass all the cabling as indicated and move all the connectors, ensuring that they have been correctly connected, behind the steering tube.



TABLE G

1. Front brake switch
2. Clamps
3. Cable guide

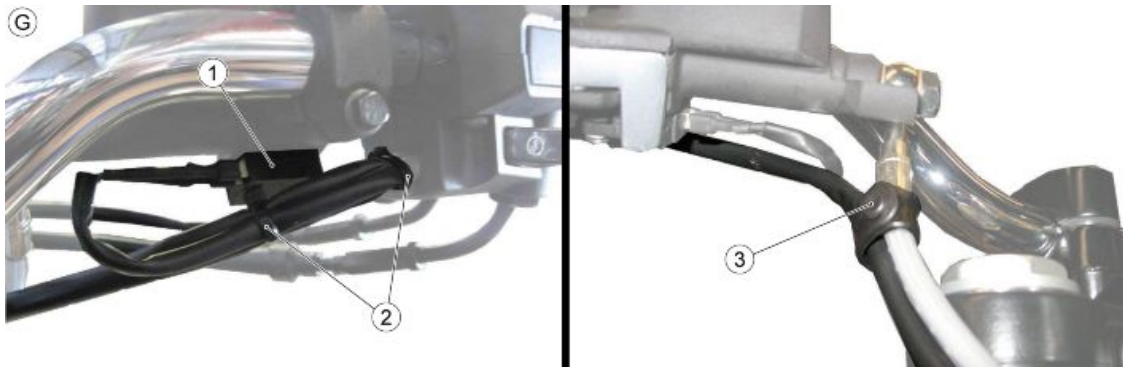

TABLE H

1. Clamp
2. Cable guide



Central part

CAUTION

ONCE THE ELECTRICAL SYSTEM IS REFITTED, THE CONNECTORS RECONNECTED AND CLAMPS AND RETAINERS RESTORED, CARRY OUT THE CHECKS INDICATED UNDER "SPECIAL CHECKS FOR THE CORRECT CONNECTION AND LAYING OF CABLES" IN THE "ELECTRICAL SYSTEM INSTALLATION" SECTION.

TABLE A

1. Oil pressure bulb
2. Engine head temperature sensor
3. Right injector
4. Rear stop switch
5. Gear in neutral switch
6. Left injector

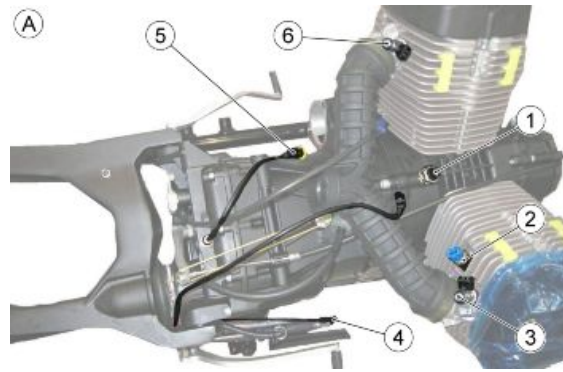

TABLE B

1. Rear stop switch
2. Clamps

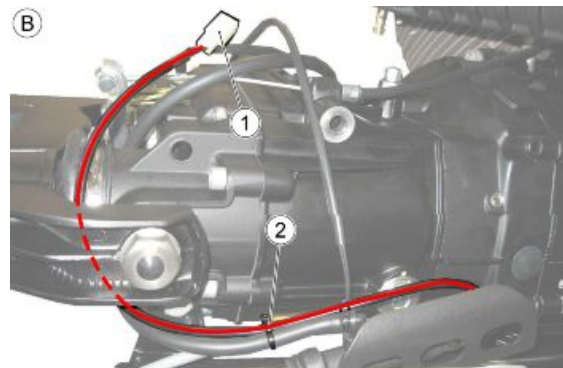

TABLE C

1. Side stand switch
2. Clamps

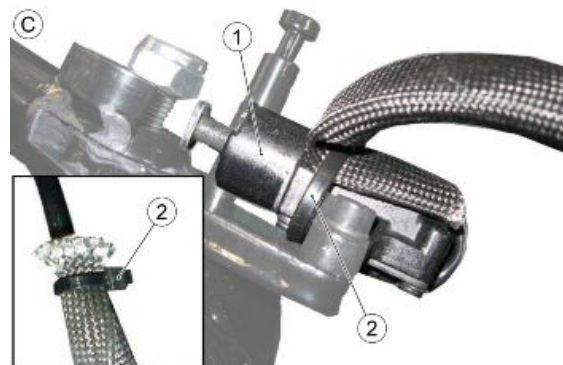

TABLE D

1. Side stand cabling
2. Cable tie that secures the side switch cabling to the frame

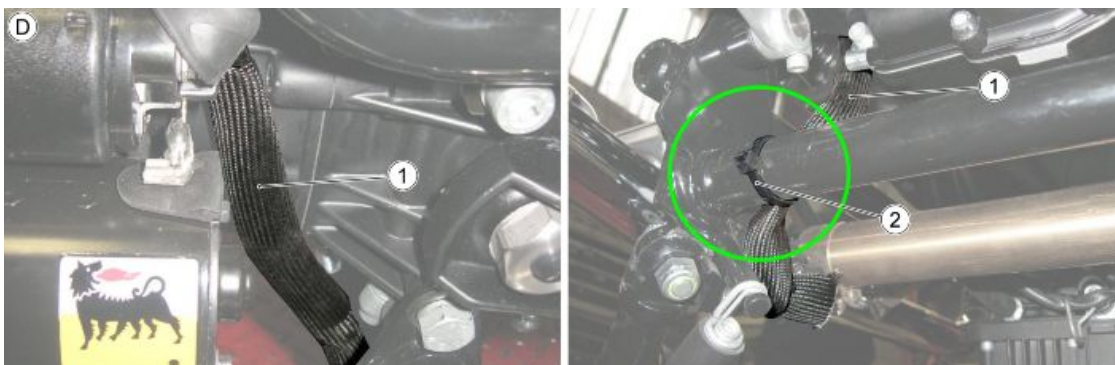
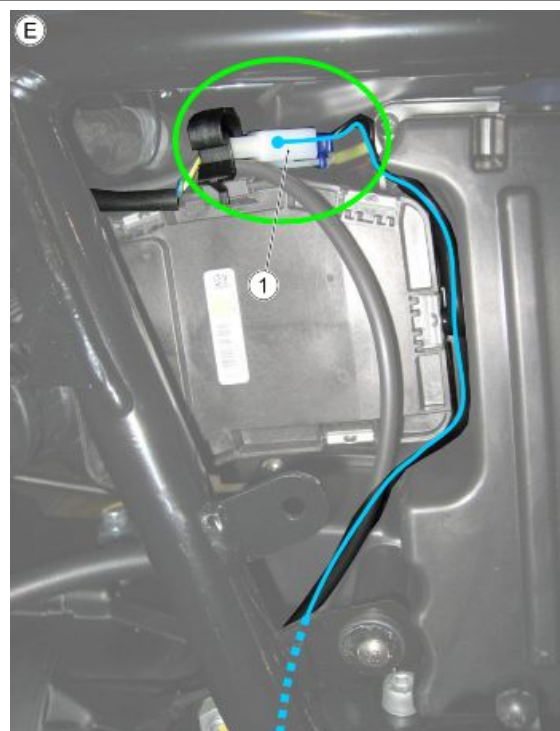
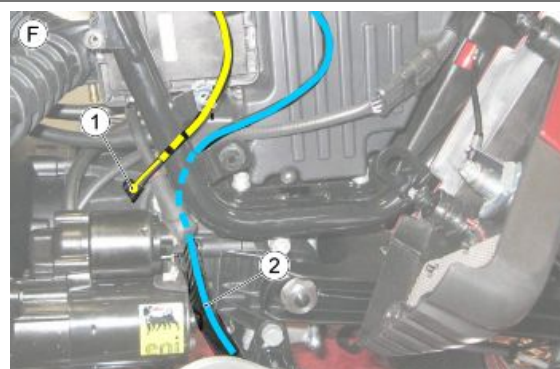

TABLE E

1. Side stand switch connector

**TABLE F**

1. Starter motor actuator connector
2. Side stand cabling

**TABLE G**

- Check that the hood which covers the starter motor positive is inserted well and that the nut is secured correctly to the prescribed torque.

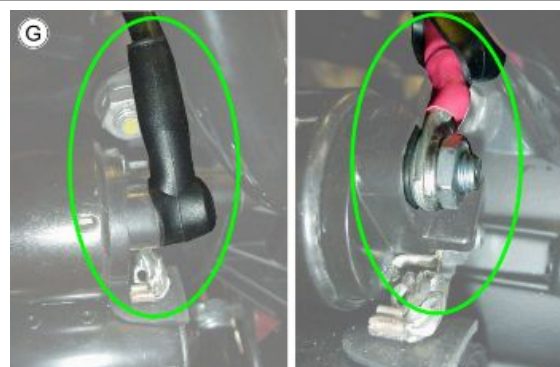

TABLE H

1. Gear in neutral switch
2. Cable grommet

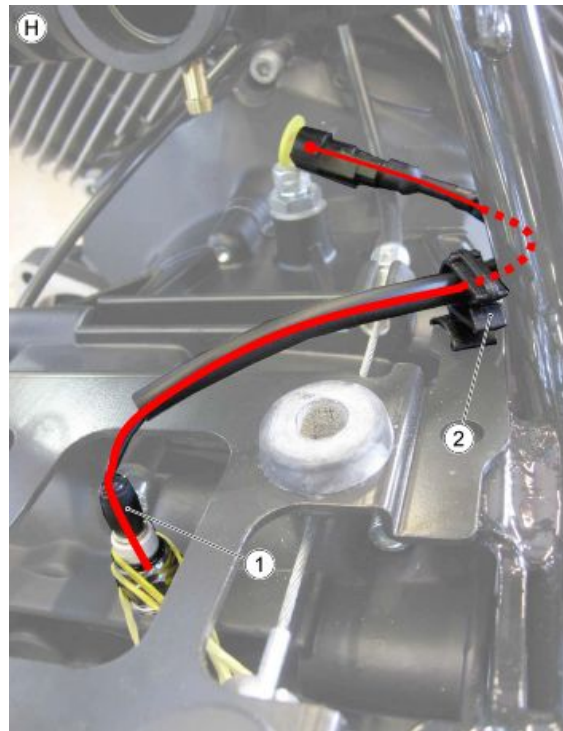

TABLE I

1. Main cable harness
2. Cable ties that secure the main cabling to the frame
3. Left cylinder coil
4. Right cylinder coil

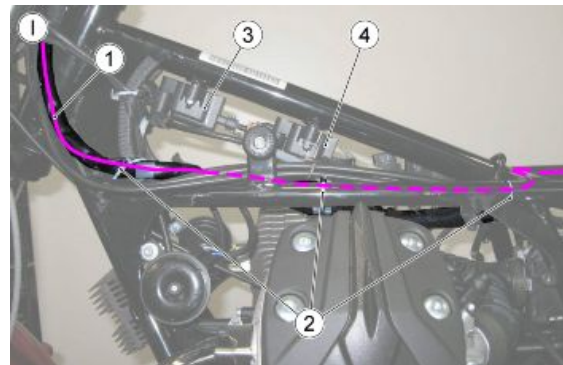

TABLE L

1. Main cable harness
2. Cable tie that secures the main cabling to the frame

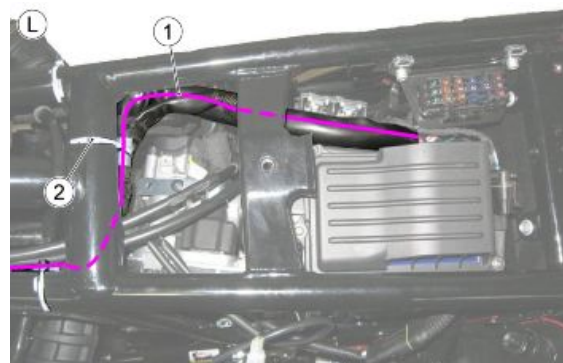

TABLE O

1. Neutral switch connector
2. Right Lambda probe connector
3. Cable tie that joins the switch connectors and the right lambda probe

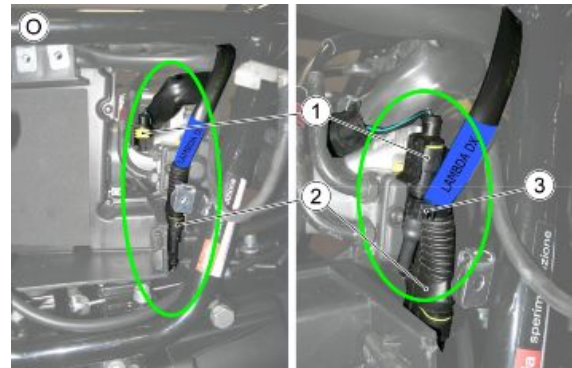

TABLE P

1. Battery positive
 - Check the cable which goes from the battery positive to the fuse box to be sure it is covered by the sheath and that the terminal is covered by the heat-shrink.
2. Battery negative
 - Check that the end of the engine ground leads is positioned as illustrated in the image and that there is perfect surface contact once the screw is tightened.
3. Taillight connector
4. Speed sensor connector
5. Clamps

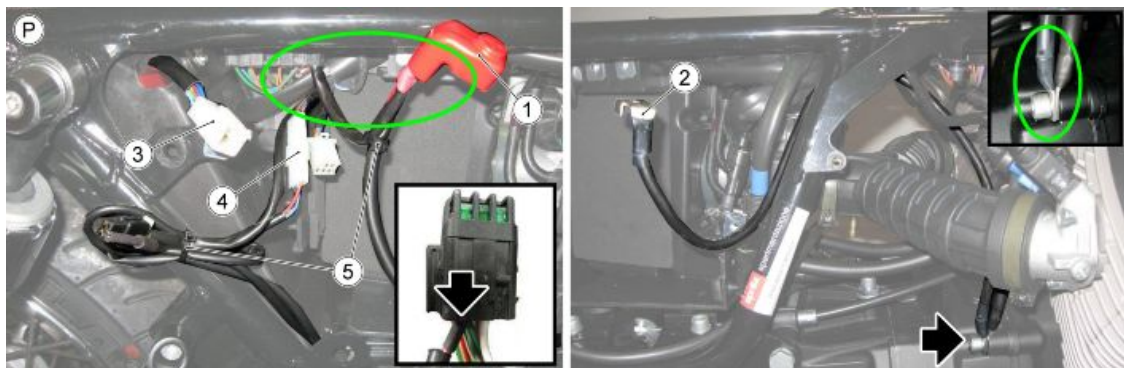
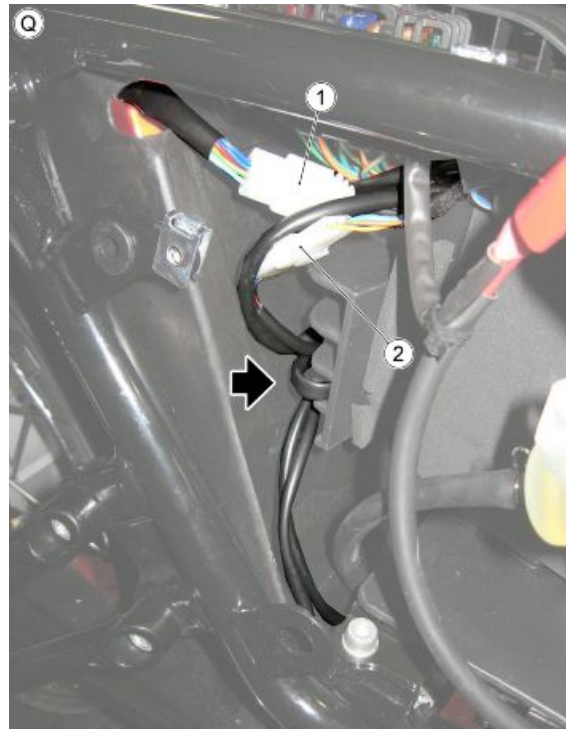

TABLE Q

1. Taillight connector
 2. Speed sensor connector
- Hide the taillight and speed sensor connectors between the filter box and mudguard

**TABLE R**

1. Engine oil bulb
2. Clamp

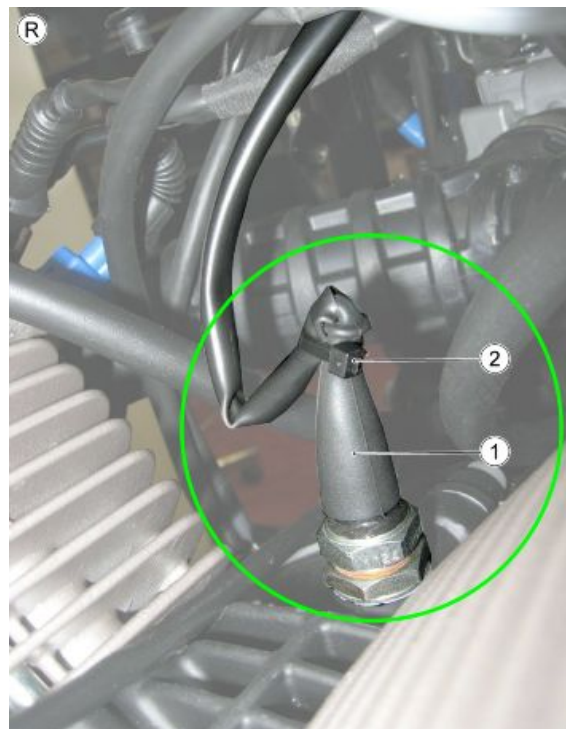

TABLE S

1. Control unit connector
2. Control unit fastening bracket

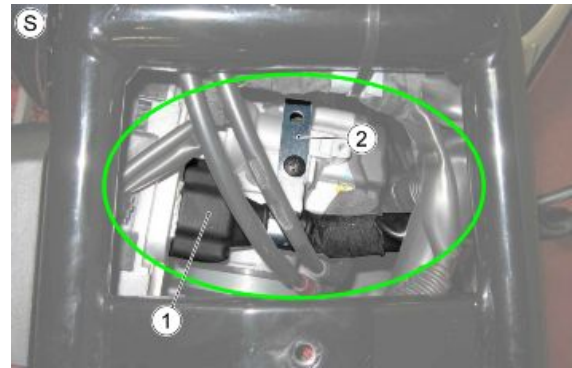

TABLE T

1. Module with resistance (Pull UP)

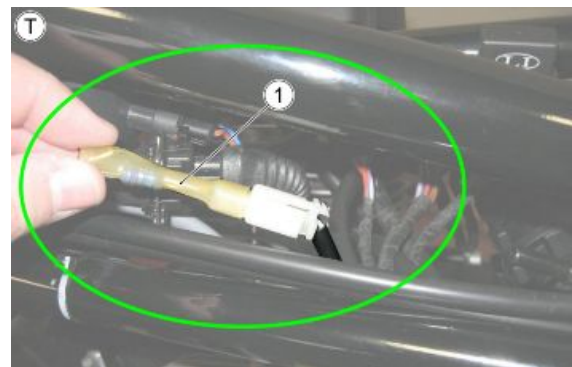

TABLE U

1. Left cylinder coil
 - The grey taping marks the left cylinder coil connector



TABLE V

1. Voltage cable
2. Coil
 - Indication of correct connection of the high voltage cable on the coils

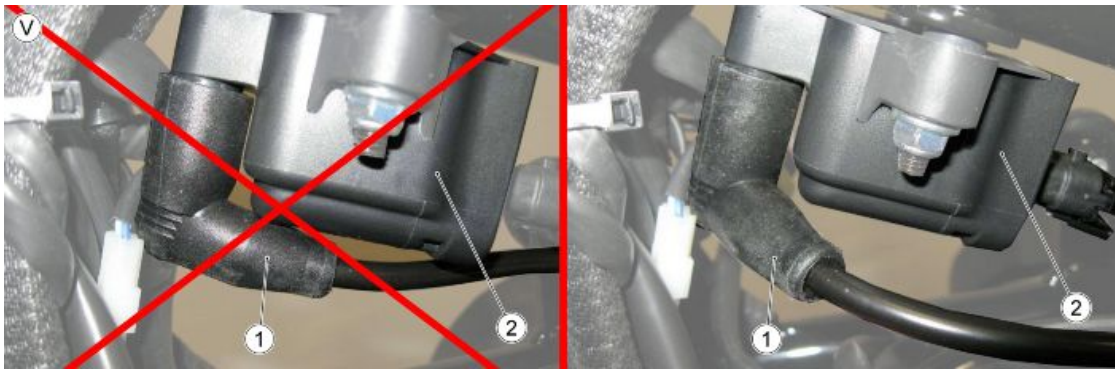

TABLE W

1. High voltage cable covered by black sheath for right cylinder
2. High voltage cable covered by grey sheath for left cylinder



TABLE X

1. Pick Up connector



TABLE Y

1. Left horn
2. Right horn

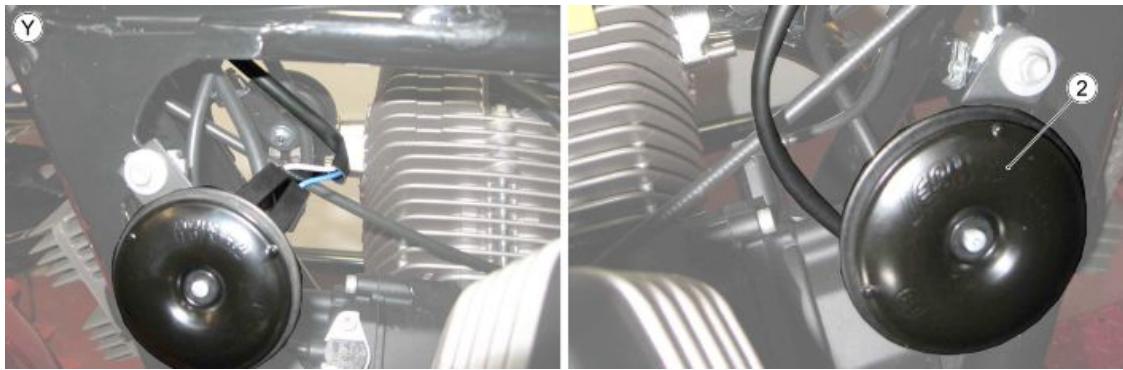

Back side

CAUTION

ONCE THE ELECTRICAL SYSTEM IS REFITTED, THE CONNECTORS RECONNECTED AND CLAMPS AND RETAINERS RESTORED, CARRY OUT THE CHECKS INDICATED UNDER "SPECIAL CHECKS FOR THE CORRECT CONNECTION AND LAYING OF CABLES" IN THE "ELECTRICAL SYSTEM INSTALLATION" SECTION.

TABLE A

1. Rear speed sensor cabling
2. Cable grommets

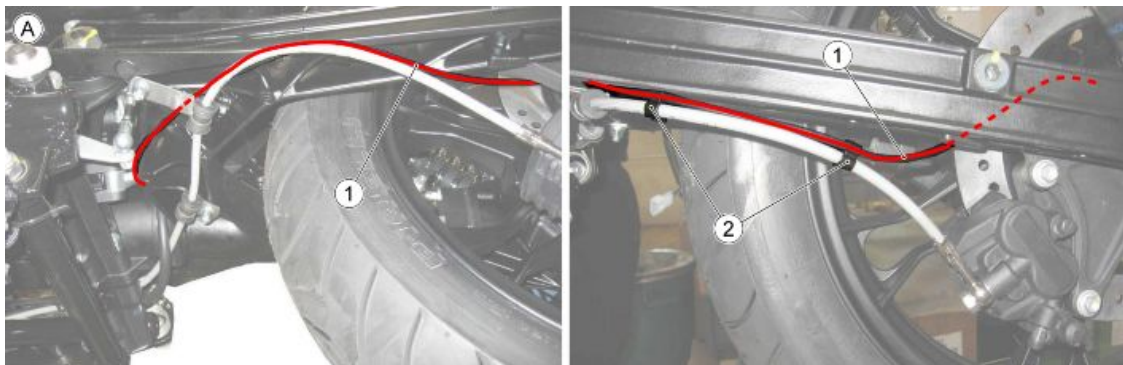

General wiring diagram

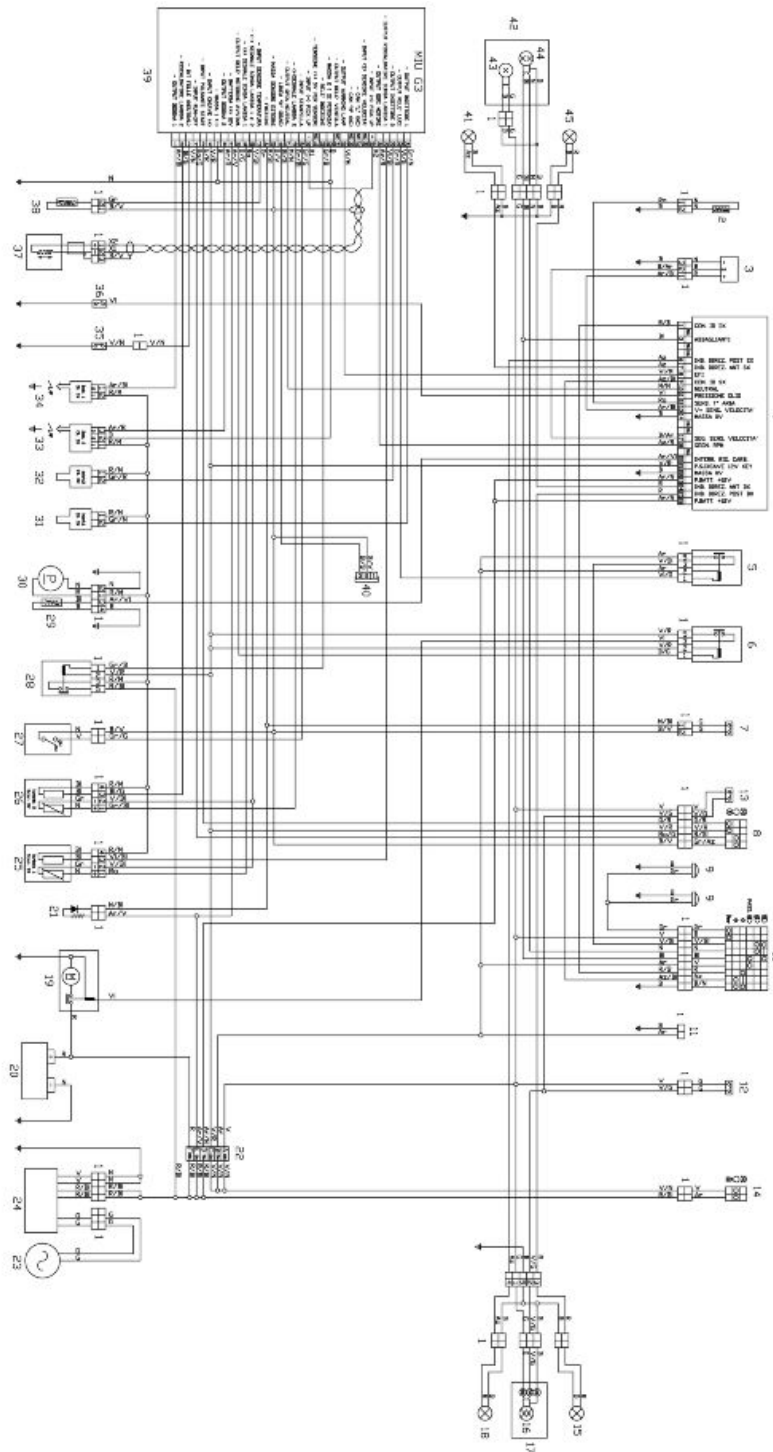

key:

- 1. Multiple connectors
- 2. Air temperature sensor
- 3. Speed sensor
- 4. Instrument panel

5. Light relay
6. Starter motor relay
7. Clutch switch
8. Right light switch
9. Horn
10. Left light switch
11. GPS wiring
12. Rear stop switch
13. Front stop switch
14. Ignition switch
15. Rear right turn indicator
16. Stop - position bulb
17. Rear light
18. Rear left turn indicator
19. Starter motor
20. Battery
21. Pull Up (resistance)
22. Fuses
23. Flywheel
24. Regulator
25. Lambda 1 (left exhaust)
26. Lambda 2 (right exhaust)
27. Side stand switch
28. Injection load relay
29. Fuel reserve sensor
30. Fuel pump
31. Injector 1 (left cylinder)
32. Injector 2 (right cylinder)
33. Coil 2 (right cylinder)
34. Coil 1 (left cylinder)
35. Neutral sensor
36. Oil sensor
37. Pick UP
38. Engine head temperature sensor
39. MIU G3 control unit
40. Diagnosis
41. Front left turn indicator
42. Headlight

- 43. Front position
- 44. High/low beam bulb
- 45. Front right turn indicator
- 46. -
- 47. -
- 48. -
- 49. -
- 50. -

Cable colour:

Ar orange

Az sky blue

B blue

Bi white

G yellow

Gr grey

M brown

N black

R red

Ro pink

V green

Vi purple

Checks and inspections

Dashboard

Service warning light reset

- The system displays the function as follows:

the word "MAInt" is shown on the left LCD Display (1) after the mileage corresponding to the first servicing or any subsequent servicing is exceeded.

- This is shown only after each start-up for 5 seconds; afterwards, it will shift to the standard view.

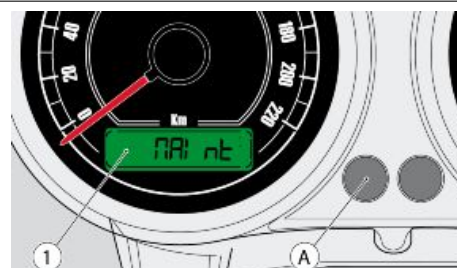

To reset Service proceed as follows:

- Hold down the key (A).
- Turn the ignition key to "ON".
- Wait for the Key OFF.

The next time the vehicle is started, the value will be reset and the word "MAInt" will not be displayed until the next mileage for which maintenance is foreseen.

Battery recharge circuit

- Effective resistance stage 1 = $0.67 - 0.47 = 0.20$ Ohm

RESISTANCE MEASURE		
Winding stage	Ambient temperature (ohm)	Afterwards heat stabilisation (ohm)
Stage 1	0.18 - 0.23	0.20 - 0.25

Empty voltage

- Disconnect the three-way connector (1);
- For a correct detection of the alternator voltage, a measurement must be carried out using alternatively the 3 engine side connector pins: stage "1" (pin 1-2), stage "2" (pin 1-3), stage "3" (pin 2-3).
- Take the measurements;
- If there is a significant difference between one stage and another (other than 15 V), this means that the alternator is defective and must be replaced.

CAUTION

WITH THE ENGINE HOT THE VALUES RECORDED ARE ON AVERAGE 4-5 V LESS THAN THOSE DETECTED WITH THE ENGINE COLD.

Giri / min	TENSIONE A VUOTO		
	2000	4000	6000
Vm tensione concatenata Valori di riferimento (V rms)	40 - 45	82 - 87	132 - 138

Short circuit current

- For a correct detection of the short circuit current, a connector must be prepared that generates a downstream short circuit between the three alternator cables;



- Start the engine and with an ammeter clamp measure each single cable.
- If there is a significant difference between the measure of the single cables (other than 10 A), this means that the alternator is defective and must be replaced.

CAUTION

WITH THE ENGINE HOT THE VALUES RECORDED ARE ON AVERAGE 2-3 A LESS THAN THOSE DETECTED WITH THE ENGINE COLD.

WARNING

NEVER KEEP THE ENGINE RUNNING FOR MORE THAN ONE MINUTE; FAILURE TO DO SO COULD CAUSE SERIOUS OVERHEATING DAMAGES TO THE MOTORCYCLE CIRCUITS.

COLD SHORT CIRCUIT CURRENT

RPM	2000	4000	6000	8000
RMS DC current (Arms) (average of the 3 stage currents)	26 - 30	20 - 25	30 - 35	30 - 35

Voltage on battery poles with engine speed always between 3000 - 5000 RPM

- Start the engine, after about one minute of operating bring the speed to 3000-5000 RPM, then measure with a tester the voltage at the battery poles that must always be between 13V and 15V. Otherwise, if the correct operation of the alternator has already been checked, replace the alternator.

CAUTION

PERFORM THE CHECK DESCRIBED ABOVE WITH A BATTERY IN GOOD CONDITION (START VOLTAGE ABOUT 13V) MAKING SURE THAT THERE ARE NO ELEMENTS IN THE SHORT CIRCUIT.

Start-up system check

pick-up input about 100 A

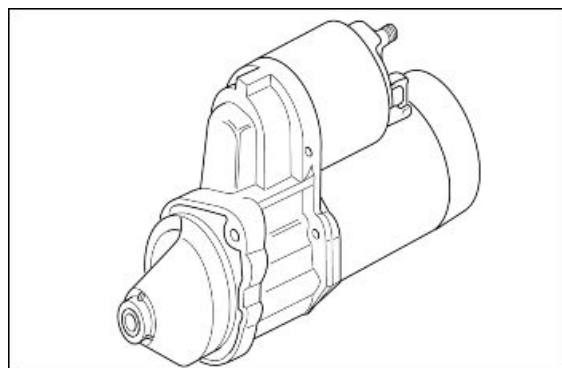

STARTER COMMAND

Function

Commands engine starting through the injection control unit.

Operation / Operating principle

The starter button, the brake switches, the No. 6 starter command relay and the injection control unit between PIN 6 and 10 are involved.

Level in electrical circuit diagram: Start-up relay

Location:

Under the fuel tank.

Pin-out:

1. control unit relay output (blue/yellow cable)
2. ignition switch live control unit (green/red cable)
3. starter motor (violet cable)
4. /
5. ignition switch live control unit (green/red cable)

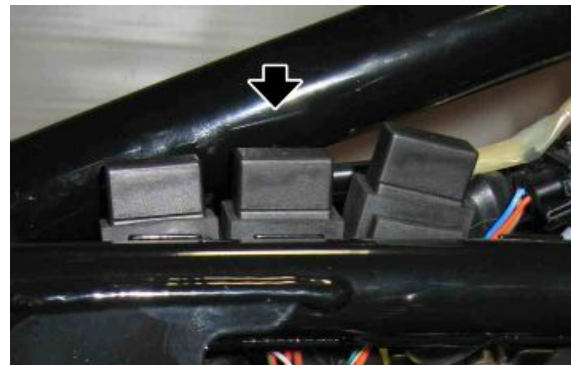
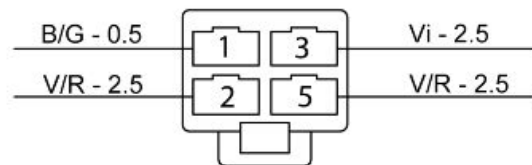

ELECTRICAL ERRORS

Starter command P0170 - shorted to positive.

Error cause

Shorted to positive: excessive voltage at PIN 10 of the control unit connector.

Troubleshooting

Shorted to positive:

- This malfunction is detected with a brake activated and the starter button pressed (voltage of 12V read at PIN 6).
- If the battery voltage does not drop (thanks to the absorption of the No. 6 starter command relay excitation coil) the control unit understands that PIN 10 is shorted to battery.
- Restore the cabling (if the short is in the cabling) or the relay (if the short is in the relay).

NOTE

IN CASE OF SHORT TO GROUND / OPEN CIRCUIT NO ERROR WILL APPEAR: SEE THE TROUBLESHOOTING CHAPTER, THE ENGINE DOES NOT START.

level indicators

Petrol pump:

Input 4A (to be measured between pins 1 and 2
with 12V supply voltage)

Fuel level sensor:

Resistance 1.4 Ohm (to be measured between
pins 3 and 4 with fuel level equal to 0 litres)

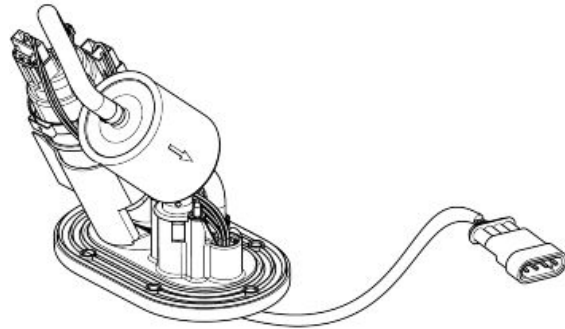

Lights list

BULBS

Specification	Desc./Quantity
Low/high beam light (halogen)	12 V - 55 W / 60 W H4
Front daylight running light	12V - 5W
Turn indicator light	12 V - 10 W (orange RY 10 W bulb)
License plate light	12V - 5 W
tail light /stop lights	12 V - 5 / 21 W
Dashboard lighting	LED

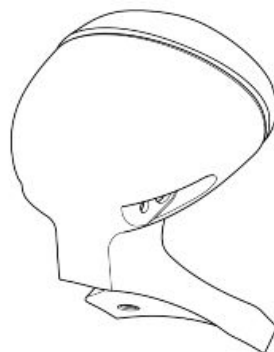
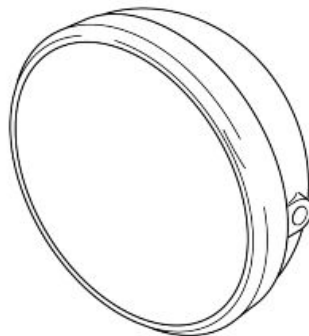

Fuses

FUSE DISTRIBUTION

- A) Stop, daylight running lights, horn (10 A).
- B) GPS installation, low / high-beam lights, passing (15 A).
- C) Control unit, engine kill, starter relay, instrument panel, injection load relay (15 A).
- D) (Battery positive) Instrument panel, turn indicators (5 A).
- E) - (Battery positive), MIU G3 Control unit (5A).
- F) Main fuse, coil 1 and 2, injector 1 and 2, lambda 1 and 2 (30 A).

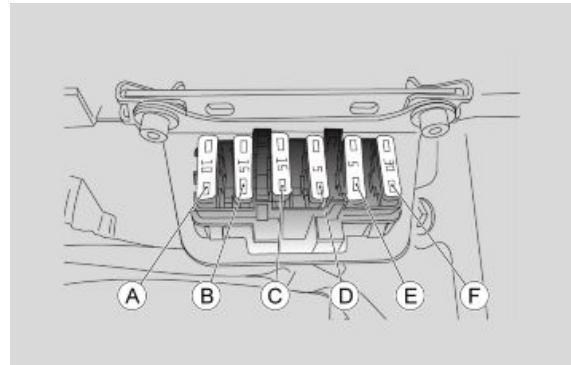

Control unit

Engine control unit Magneti Marelli MIU G3

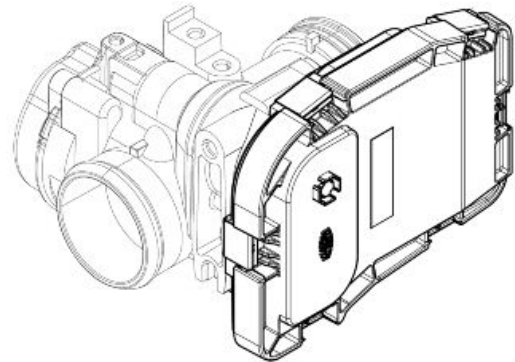

Battery

Characteristic

Battery

12V - 12 Ah

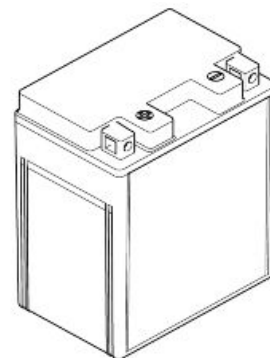

Speed sensor

Function

To indicate the vehicle speed by reading the rear wheel turning speed.

Operation / Operating principle

Hall effect sensor: a square-wave pulse is generated with voltage between 12V and approximately 0.6 V.

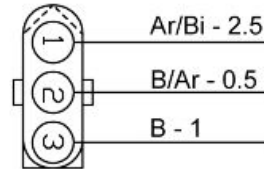

Level in electrical circuit diagram:

Speed sensor

Location:

- Sensor: on the swingarm, left side, next to the rear brake calliper.
- Connector: under right fairing, next to the Marelli control unit.



Pin-out:

PIN:

- PINS 1-3 Voltage: approx. 12 V
 - PINS 2-3 Voltage: between 0.6V-12V (turning the rear wheel)
1. Power supply voltage (Orange/White - sensor side)
 2. Output signal (Blue/Orange - sensor side)
 3. Ground (Blue - sensor side)



ELECTRICAL ERRORS

Error cause

Faulty sensor or cabling, interference on the signal

Troubleshooting

- Disconnect the sensor connector.
- Verify, with the key ON, the voltage between sensor PIN 1-3.
- If no voltage is detected, check the continuity of the cabling between sensor PIN 1 and instrument panel connector PIN 13.
- Carry out the check procedure on instrument panel connector PIN 13.
- If the cabling is intact, check for continuity with the sensor PIN 3 ground.
- Check continuity of the cabling between sensor PIN 2 and instrument panel connector PIN 17.

- Carry out the check on instrument panel PIN 17.
- In the event that these checks have not detected the fault, replace the sensor.

Engine rpm sensor

Function

It informs crankshaft position and speed to the Marelli control unit.

Operation / Operating principle

Inductive sensor: sinusoidal-type generated voltage; two teeth are missing on the flywheel for the reference position.

Level in electrical circuit diagram: engine speed sensor

Location:

- Sensor: engine front left section, under the left cylinder.
- Connector: under the fuel tank.

Electrical characteristics:

- Winding resistance: $650 \Omega \pm 15\%$ Output alternating voltage, value range: minimum: 0.5 V - maximum: 5 V

Pin-out:

1. Engine speed sensor positive signal (cable X2)
2. Engine speed sensor negative signal (cable X1)
3. Engine speed sensor anti-jamming cable (blue/green cable)

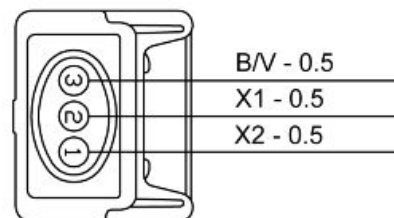
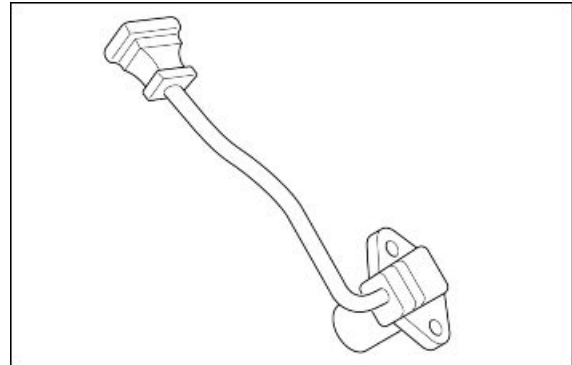

PARAMETERS

Target engine revs

Example value: 1100 +/- 100 rpm

Parameter valid at idle, setting depends especially on engine temperature: the ECU unit will try to keep the engine running at this revs, acting on the ignition advance.

STATUSES

Synchronisation

Example value: Synchronised / Not synchronised

Indicates if the control unit detects the engine speed sensor signal correctly

ELECTRICAL ERRORS

Cause

Faulty cabling or pick up

Troubleshooting

- An interruption in the sensor circuit has been detected, from PIN 20 to PIN 29 of the control unit connector.
- Check the sensor connector and the injection ECU connector:
- If the values are incorrect restore them.
- If the values are correct, check the continuity of the two cables that go from PIN 20 to PIN 29 of the control unit connector:
- If there is no continuity, restore the cabling.
- If there is continuity check interruption in the sensor and replace it.

Short circuit.

- Conduct an electrical check of the sensor.
- If the sensor check value is incorrect replace it.
- If the value is correct, check insulation of the power from ground of the two cables.
- Conduct tests from the sensor connector toward the sensor.
- If the sensor value is incorrect restore the cabling/replace the sensor.
- If the value is correct conduct tests from PIN 20 and 29 of the Marelli control unit connector toward the cable harness.

Installation

Place the sensor plus the corresponding spacers; the air gap should be between 0.7 and 0.9 mm.

Engine temperature sensor

Function

indicates the engine temperature to the control unit so as to optimise carburetion and idle control

Operation / Operating principle

NTC type sensor (resistance sensor, inversely variable with temperature).

Level in electrical circuit diagram:Temperature sensors

Location:

- on the right head, next to the throttle body
- connector: on the sensor

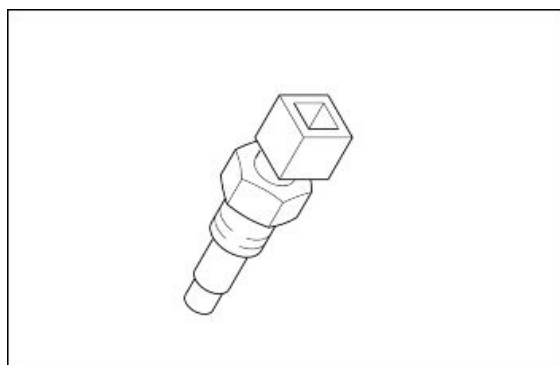

Electrical characteristics:

- Resistance at 0°C: 9.75 kΩ ± 5%
- Resistance at 20°C: 3.747 kΩ ± 5%
- Resistance at 40°C: 1.598 kΩ ± 5%
- Resistance at 60°C: 0.746 kΩ ± 5%
- Resistance at 80°C: 0.377 kΩ ± 5%
- Resistance at 100°C: 0.204 kΩ ± 5%

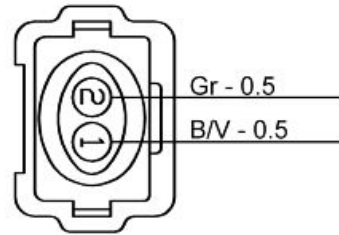
**Pin-out:**

- Grey (cable harness side): 0-5 V signal
- Blue/green (cable harness side): Ground connection

**ELECTRICAL ERRORS**

Engine temperature sensor P0115 - open circuit or shorted to positive / shorted to negative.

Error cause

Open circuit or shorted to positive: interruption of the circuit or excessive voltage at PIN 13 of the control unit connector.

Shorted to negative: null voltage between PIN 13 and 15 of the control unit connector.

Troubleshooting

The circuit is open:

- Disconnect the connector of the control unit.
- Measure the resistance value of the sensor at different temperatures between PIN 13 and 15.
- Disconnect the sensor connector.
- Verify continuity of the cabling between the sensor connector and the control unit connector: Control unit PIN 13 - sensor PIN 2 and control unit PIN 15 - sensor PIN 1. Restore the cabling if necessary.
- If the cabling is intact but the sensor resistance value is incorrect, this means that the sensor is faulty and must be replaced, otherwise proceed with the checks.

Shorted to positive:

- With the sensor connector and the control unit disconnected, verify that the fault is shorted with the battery positive of sensor connector PIN 2 (or control unit PIN 13) and restore the cabling.

Shorted to negative:

- Disconnect the sensor connector.
- Check the sensor connector PIN 2 ground insulation.
- If there is no ground insulation restore the cabling.
- If PIN 2 is insulated from the ground and the error persists, this means that there is a probable fault in the control unit.

Lambda sensor

Function

In charge of telling the control unit whether the mixture is lean or rich.

Operation / Operating principle

The Marelli injection control unit reads and interprets a voltage generated by the difference in oxygen content between the exhaust fumes and the ambient. It does not require an external supply source but, in order to work properly, it should reach a high operating temperature: that is why there is a heating circuit inside.

Level in electrical circuit diagram: Right Lambda probe

Location:

- sensor: right exhaust pipe
- connector: near the throttle body right side

Electrical characteristics:

Heater circuit: 12 -14 Ω at 20 °C (68 °F)

Pin-out:

1. Sensor signal + (grey/white wire)
2. Sensor signal - (green/white wire)
3. Heater ground (white/yellow)
4. Heater power supply (white)

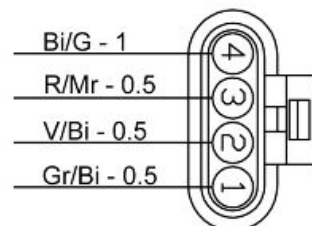
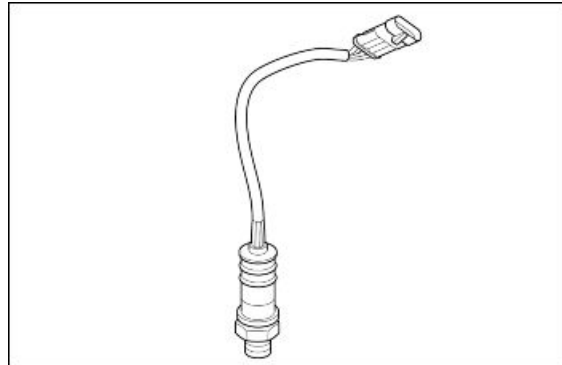



ELECTRICAL ERRORS

Check the air-fuel ratio / right Lambda probe P0130 - short to positive / open circuit, short to negative or carburetion excessively lean / signal not plausible for abnormal title correction or probe signal fault.

Error cause

Shorted to positive: excessive voltage at PIN 18 or PIN 12 of the control unit connector.

Circuit open or shorted to negative: interruption of the circuit or null voltage between control unit connector PIN 18 and 12.

Troubleshooting

Shorted to positive:

- Disconnect the control unit connector and the sensor connector.
- Verify that there is no short to battery positive on sensor connector PIN 1 (corresponding to control unit connector PIN 18); if there is a short, restore the cabling.
- Verify that there is no short to battery positive on sensor connector PIN 2 (corresponding to control unit connector PIN 12); if there is a short, restore the cabling.

The circuit is open:

- Disconnect the control unit connector and the sensor connector.
- Verify continuity of the cabling between the sensor connector and the control unit connector: Control unit PIN 18 - sensor PIN 1 and control unit PIN 12 - sensor PIN 2. Restore the cabling if necessary.
- If the cabling is intact and the error persists, proceed with the following checks.

Shorted to negative:

- Disconnect the sensor connector and the control unit connector.
- Check the sensor connector PIN 1 ground insulation. In the absence of insulation restore the cabling.
- Check the sensor connector PIN 2 ground insulation. In the absence of insulation restore the cabling.
- If PIN 1 and PIN 2 are insulated from the ground and the error persists, this means that there is a probable fault in the control unit.

Lambda probe heater P0135 - shorted to positive / shorted to negative / open circuit.

Error cause

Shorted to positive: excessive voltage at PIN 2 of the control unit connector.

Shorted to negative: lack of insulation from ground on the sensor connector PIN 4.

The circuit is open: interruption of the circuit.

Troubleshooting

Shorted to positive:

- Disconnect the control unit connector and the sensor connector.
- Verify that there is no short to battery positive on sensor connector PIN 3 (corresponding to control unit connector PIN 2); if there is a short, restore the cabling.

The circuit is open:

- Disconnect the control unit connector and the sensor connector.
- Verify continuity of the cabling between the sensor connector and the control unit connector: Control unit PIN 2 - sensor PIN 3. Restore the cabling if necessary.
- Verify continuity of the cabling between the sensor connector and the injection relay: sensor PIN 4 - injection relay PIN 3. Restore the cabling if necessary.
- If the cabling is intact and the error persists, proceed with the following checks.

Shorted to negative:

- Disconnect the sensor connector.
- Check the sensor connector PIN 3 ground insulation. In the absence of insulation restore the cabling.
- If PIN 3 is insulated from ground and in the absence of other errors (fuel pump, injector, coil), this means that the control unit is most likely faulty.

LEFT LAMBDA

Level in electrical circuit diagram: Left lambda probe

Location:

- sensor: right exhaust pipe
- connector: adjacent to the filter box, left side

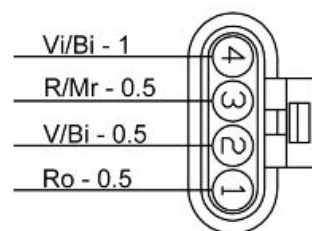
**Electrical characteristics:**

Heater circuit: 12 -14 Ω at 20 °C (68 °F)

Pin-out:

1. Sensor signal + (pink wire)
2. Sensor signal - (green/white wire)
3. Heater ground (violet/white)
4. Heater power (red/brown cable)

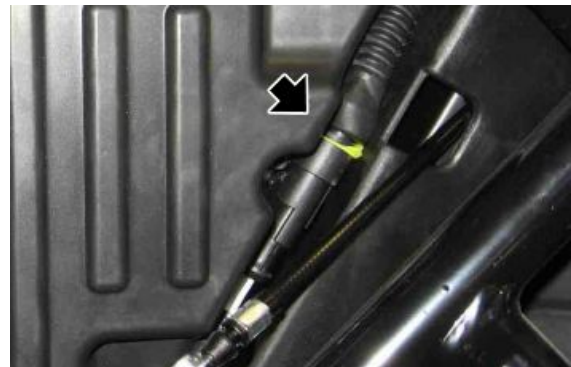
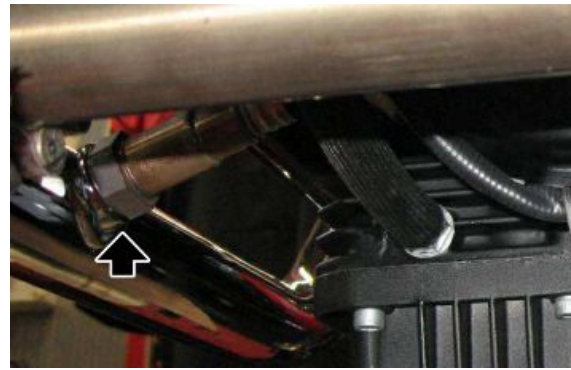

ELECTRICAL ERRORS

Check the air-fuel ratio / right Lambda probe P0136 - short to positive / open circuit, short to negative or carburetion excessively lean / signal not plausible for abnormal title correction or probe signal fault.

Error cause

Shorted to positive: excessive voltage at PIN 11 or PIN 12 of the control unit connector.

Circuit open or shorted to negative: interruption of the circuit or null voltage between control unit connector PIN 11 and 12.

Troubleshooting

Shorted to positive:

- Disconnect the control unit connector and the sensor connector.
- Verify that there is no short to battery positive on sensor connector PIN 1 (corresponding to control unit connector PIN 11); if there is a short, restore the cabling.
- Verify that there is no short to battery positive on sensor connector PIN 2 (corresponding to control unit connector PIN 12); if there is a short, restore the cabling.

The circuit is open:

- Disconnect the control unit connector and the sensor connector.
- Verify continuity of the cabling between the sensor connector and the control unit connector: Control unit PIN 11 - sensor PIN 1 and control unit PIN 12 - sensor PIN 2. Restore the cabling if necessary.
- If the cabling is intact and the error persists, proceed with the following checks.

Shorted to negative:

- Disconnect the sensor connector and the control unit connector.
- Check the sensor connector PIN 1 ground insulation. In the absence of insulation restore the cabling.
- Check the sensor connector PIN 2 ground insulation. In the absence of insulation restore the cabling.
- If PIN 1 and PIN 2 are insulated from the ground and the error persists, this means that there is a probable fault in the control unit.

Lambda probe heater P0141 - shorted to positive / shorted to negative / open circuit.

Error cause

Shorted to positive: excessive voltage at PIN 35 of the control unit connector.

Shorted to negative: lack of insulation from ground on the sensor connector PIN 4.

The circuit is open: interruption of the circuit.

Troubleshooting

Shorted to positive:

- Disconnect the control unit connector and the sensor connector.
- Verify that there is no short to battery positive on sensor connector PIN 3 (corresponding to control unit connector PIN 31); if there is a short, restore the cabling.

The circuit is open:

- Disconnect the control unit connector and the sensor connector.
- Verify continuity of the cabling between the sensor connector and the control unit connector: Control unit PIN 31 - sensor PIN 3. Restore the cabling if necessary.
- Verify continuity of the cabling between the sensor connector and the injection relay: sensor PIN 4 - injection relay PIN 3. Restore the cabling if necessary.
- If the cabling is intact and the error persists, proceed with the following checks.

Shorted to negative:

- Disconnect the sensor connector.
 - Check the sensor connector PIN 3 ground insulation. In the absence of insulation restore the cabling.
 - If PIN 3 is insulated from ground and in the absence of other errors (fuel pump, injector, coil), this means that the control unit is most likely faulty.
-

Injector

Function

To supply the correct amount of petrol at the right timing.

Operation / Operating principle

Injector coil is excited for the petrol passage to open.

Level in electrical circuit diagram: Coils and injectors

Right injector position:

- on the intake manifold
- connector: on injector

Electrical characteristics: 14.8 Ohm +/- 5% (at 20 °C - 68 °F)

Pin-out:

1. Power 12V (red/brown cable)
2. Ground (grey/red cable)

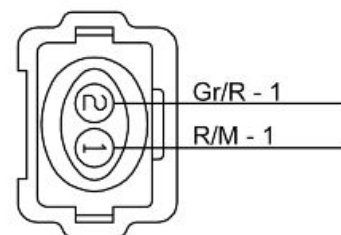

ELECTRICAL ERRORS

Front injector P0201 - shorted to positive / shorted to negative / open circuit.

Error cause

Shorted to positive: excessive voltage at PIN 32 of the control unit connector.

Shorted to negative: null voltage at PIN 1 of the injector connector.

The circuit is open: interruption of the circuit.

Troubleshooting

Shorted to positive:

- Disconnect the injector connector, turn the key to ON and activate the component through the diagnostics instrument.
- Verify the absence of voltage at the injector connector PIN 2; if present, restore the cabling, otherwise proceed with the following checks.

Shorted to negative:

- Disconnect the injector connector, turn the key to ON and activate the component through the diagnostics instrument.
- Verify the presence of voltage at the ends of the injector connector; if there is no voltage, restore the cabling, otherwise proceed with the following checks.

The circuit is open:

- Carry out the check procedure of the injector and control unit connectors.
- Verify continuity of the cabling between the control unit connector and the injector connector (control unit PIN 32 - injector PIN 2). In the absence of continuity restore the cabling.

LEFT INJECTOR

Level in electrical circuit diagram: Coils and injectors

Left injector position:

- on the intake manifold
- connector: on injector

Electrical characteristics: 14.8 Ohm +/- 5% (at 20 °C - 68 °F)

Pin-out:

1. Power 12V (red/brown cable)
2. Ground (grey/black cable)

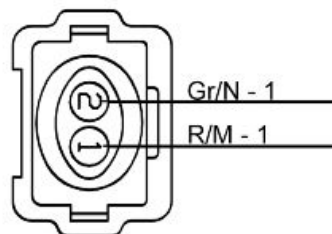

ELECTRICAL ERRORS

Left injector P0202 - shorted to positive / shorted to negative / open circuit.

Error cause

Shorted to positive: excessive voltage at PIN 32 of the control unit connector.

Shorted to negative: null voltage at PIN 1 of the injector connector.

The circuit is open: interruption of the circuit.

Troubleshooting

Shorted to positive:

- Disconnect the injector connector, turn the key to ON and activate the component through the diagnostics instrument.
- Verify the absence of voltage at the injector connector PIN 2; if present, restore the cabling, otherwise proceed with the following checks.

Shorted to negative:

- Disconnect the injector connector, turn the key to ON and activate the component through the diagnostics instrument.
- Verify the presence of voltage at the ends of the injector connector; if there is no voltage, restore the cabling, otherwise proceed with the following checks.

The circuit is open:

- Carry out the check procedure of the injector and control unit connectors.
- Verify continuity of the cabling between the control unit connector and the injector connector (control unit PIN 34 - injector PIN 2). In the absence of continuity restore the cabling.

Fuel pump

Function

Fuel pump: keeps pressure of the injectors supply duct.

Low fuel: tells to the instrument panel about low fuel

Operation / Operating principle

Low fuel: it is a resistance that if correctly supplied varies its electrical resistance if it is damped or not by petrol.

Level in electrical circuit diagram:

Injection load relay

Location:

- on the vehicle: on the tank.
- connector: on the front left part of the bike, under the fuel tank.

Electrical characteristics:

Pin out:

1. + 12V (red/brown cable)
2. ground (black cable)
3. Signal + to instrument panel (orange/violet cable)
4. Ground (blue cable)

CAUTION

BEFORE CARRYING OUT ANY TROUBLESHOOTING, CAREFULLY READ THE GENERAL TROUBLESHOOTING CONCEPTS FOR ELECTRICAL DEVICES AT THE BEGINNING OF THE CHECK AND CONTROL SECTION IN THE ELECTRICAL SYSTEM CHAPTER.

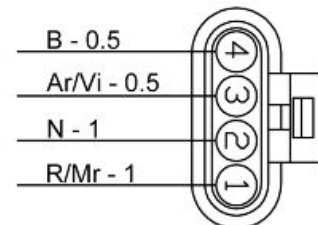

ELECTRICAL ERRORS

Fuel pump relay P0230 - shorted to positive / shorted to negative / open circuit.

Error cause

Shorted to positive: excessive voltage at PIN 22 of the control unit connector.

Shorted to negative: null voltage at PIN 2 of the injection relay.

The circuit is open: interruption of the circuit.

Troubleshooting

Shorted to positive:

- Disconnect the injection relay (No. 28 on the electrical circuit diagram), turn the key to the ON position and activate the relay through the diagnostics instrument.
- Verify the presence of voltage between relay connector PIN 1 and 2 toward the cabling.
- If no voltage is read, disconnect the control unit and verify insulation from battery positive of the relay PIN 1 (or control unit PIN 22). Restore the cabling if necessary.

Shorted to negative:

- Disconnect the injection relay (No. 28 on the electrical circuit diagram) and the control unit.
- Verify ground insulation of the relay connector PIN 1 and 2 toward the cabling: if there is no insulation, restore the cabling.

The circuit is open:

- Disconnect the injection relay (No. 28 on the electrical circuit diagram) and the control unit.
- Verify continuity of the cabling between the relay and control unit: Relay PIN 1 - control unit PIN 22. Restore the cabling if necessary.

Coil**Function**

It controls the ignition spark plug in order to generate the fuel ignition spark.

Operation / Operating principle

Inductive discharge system.

Level in electrical circuit diagram: Left coil and injector

Location:

- centred under the fuel tank.
- connector: on the coils.

Electrical characteristics:

- Primary winding resistance: $550 \text{ k}\Omega \pm 10\%$

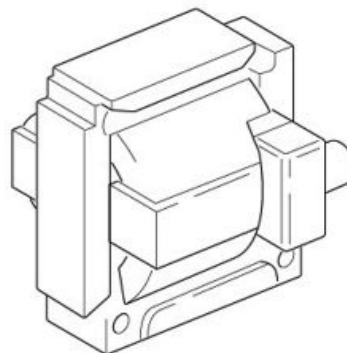

- Secondary winding resistance: $3\text{ k}\Omega \pm 10\%$
- Tube resistance $5\text{ k}\Omega$

Pin-out:

1. Circuit ground (orange/white cable)
2. Power (red/brown cable)

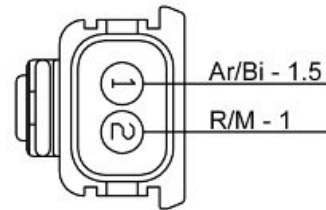
**ELECTRICAL ERRORS**

H.V. Coil P0351 - shorted to positive / open circuit or shorted to negative.

Error cause

Shorted to positive: excessive voltage at PIN 1 of the control unit connector.

Circuit open or shorted to negative: interruption of the circuit or null voltage at PIN 1 of the control unit connector.

Troubleshooting

Shorted to positive:

- Disconnect the coil connector, turn the key to ON and activate the component through the diagnostics instrument.
- Verify the presence of voltage on the coil connector PIN 1: if present, restore the cabling, otherwise replace the coil.

The circuit is open:

- Carry out the check procedure of the coil and control unit connectors.
- Verify continuity of the cabling between the coil and control unit: Coil PIN 1 - control unit PIN 1. In the absence of continuity restore the cabling.
- Verify, with the key turned ON, the presence of voltage on the coil connector PIN 2. If no voltage is read, verify the continuity of the cabling between coil and injection relay (No. 34 on the electrical circuit diagram): Coil PIN 2 - relay PIN 3.
- If the above tests provided a positive result, the coil should be replaced.

Shorted to negative:

- Disconnect the control unit connector and the coil connector.
- Verify the coil connector PIN 1 ground insulation (or control unit connector PIN 1). Restore the cabling if necessary.

RIGHT COIL

Level in electrical circuit diagram: Right coil and injector

Location:

- centred under the fuel tank.
- connector: on the coils.

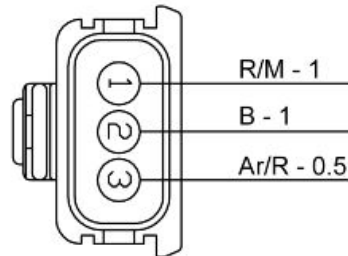

Electrical characteristics:

- Primary winding resistance: $550\text{ k}\Omega \pm 10\%$
- Secondary winding resistance: $3\text{ k}\Omega \pm 10\%$
- Tube resistance $5\text{ k}\Omega$



Pin-out:

1. Power (red/brown cable)
2. Power ground 2 (blue cable)
3. Circuit ground (orange/red cable)

ELECTRICAL ERRORS

H.V. Coil P0352 - shorted to positive / open circuit or shorted to negative.

Error cause

Shorted to positive: excessive voltage at PIN 8 of the control unit connector.

Circuit open or shorted to negative: interruption of the circuit or null voltage at PIN 8 of the control unit connector.

Troubleshooting

Shorted to positive:

- Disconnect the coil connector, turn the key to ON and activate the component through the diagnostics instrument.
- Verify the presence of voltage on the coil connector PIN 3: if present, restore the cabling, otherwise replace the coil.

The circuit is open:

- Carry out the check procedure of the coil and control unit connectors.
- Verify continuity of the cabling between the coil and control unit: Coil PIN 3 - control unit PIN 8. In the absence of continuity restore the cabling.

- Verify, with the key turned ON, the presence of voltage on the coil connector PIN 1. If no voltage is read, verify the continuity of the cabling between coil and injection relay (No. 33 on the electrical circuit diagram): Coil PIN 1 - relay PIN 3.
- If the above tests provided a positive result, the coil should be replaced.

Shorted to negative:

- Disconnect the control unit connector and the coil connector.
- Verify the coil connector PIN 3 ground insulation (or control unit connector PIN 8). Restore the cabling if necessary.

Engine oil pressure sensor

Function: Indicates the instrument panel if there is enough oil pressure (0.35 +/- 0.2 bar) (5.1 +/- 2.9 PSI) in the engine.

Operation / Operating principle: normally closed switch. With oil pressure above 0.35 +/- 0.2 bar (5.1 +/- 2.9 PSI), open circuit.

Level in wiring diagram: fuel reserve and oil pressure.

Location:

- sensor: between the two heads, at the back.
- connector: on the sensor.

Electrical characteristics:

- With engine off: closed circuit (continuity).
- With engine started: open circuit (infinite resistance).

Pin-out: Voltage 12V

Instrument panel

Warning light always off

Troubleshooting

- Check the sensor connector and the instrument panel connector (PIN 11): If not OK, restore. If OK, check the continuity of the purple cable between the sensor connector and the instrument panel connector PIN 11: if not OK, restore the cable harness; if OK, replace the sensor

Warning light always on

Troubleshooting



- Detach the sensor connector and check the purple cable is ground insulated: if there is continuity to ground, restore the cable harness; if it is ground insulated, replace the switch. If this error persists, use a pressure gauge to check the pressure of the oil in the engine circuit

Neutral sensor

Function

it tell the gear position to the instrument panel: if it is in neutral or in gear.

Operation / Operating principle

for neutral gear, the circuit is closed to ground connection: the instrument panel turns on the neutral warning light.

Level in electrical circuit diagram: Start-up enabling switches

Location:

- sensor: rear / upper section of the gear-box
- connector: on the sensor

Electrical characteristics:

- Gear in neutral: closed circuit (0 V on wire from control unit to sensor / switch in continuity).
- Gearshift engaged: circuit open (12 V on the wire from control unit to sensor)

Pin-out:

1. Voltage 12V (green/black cable)

Instrument panel

NEUTRAL warning light always off

Troubleshooting

- Carry out the check procedure on the green black sensor/control unit cable.
- Restore if damaged.
- If OK, with the transmission in neutral, check for continuity to ground of the sensor connector.
- If there is no continuity, replace the sensor.
- If OK, carry out the check procedure of the brown black cable between control unit and instrument panel.



- Restore if damaged.
- If OK, check continuity.
- If there is no continuity, restore the cabling.
- If OK, replace the instrument panel if the vehicle performs properly.

NEUTRAL Warning light always on

Troubleshooting

- Disconnect the terminals from the sensor and verify that, with the transmission in gear, there is continuity with the ground.
- If there is continuity, replace the sensor.
- If there is no continuity this means that there is a short to ground of the green black cable which goes to PIN 3 of the control unit, therefore restore the cabling.
- If the error persists, disconnect the terminals from control unit PIN 17 to instrument panel PIN 10 and verify continuity.
- If there is no continuity, restore the cabling.
- If there is no continuity, replace the cabling.

Clutch lever sensor

Function

It tells the clutch lever position to the control unit.

Operation / Operating principle

In order to start the engine, pull the clutch also with the gear in neutral.

Level in electrical circuit diagram: Start-up enabling switches.

Location:

- sensor: under clutch lever
- connector: under the fuel tank on right side

Electrical characteristics:

- Clutch pulled: closed circuit (continuity)
- Clutch released: open circuit (infinite resistance)

Pin-out:

1. 12 V Voltage (brown white cable)
2. Ground (blue black cable)

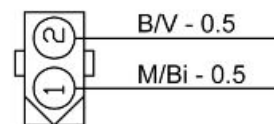

Even with the clutch lever pulled, the vehicle does not start

Troubleshooting

- Verify that, if a gear is engaged, the stand is up.
- If it is up, check continuity of the brown/white cable and control unit PIN 14.
- If there is no continuity, restore the cabling.
- If there is continuity, disconnect the sensor and, with the clutch pulled, check for continuity between the two sensor PINs.
- If absent, replace the sensor.
- If present, check for continuity of the blue violet cable between the sensor and control unit PIN 15.
- If absent, restore the cable harness.

The vehicle starts even without pulling the clutch leverTroubleshooting

- Disconnect the terminals from the sensor and check that, with the clutch released, there is continuity between the two PINs.
- If there is continuity, replace the sensor.
- If there is no continuity, this means that the blue violet cable which goes from the sensor PIN 2 to the control unit PIN 15 is shorted to ground.

Side stand sensor**Function**

It tells the side stand position to the control unit.

Operation / Operating principle

If the gear is engaged and the side stand is unfolded, and therefore the circuit is open, the control unit does not enable vehicle start-up or shuts off the engine if it is rotating.

Level in electrical circuit diagram: Start-up enabling switches

Location:

- sensor: on side stand supporting plate
- connector: left side, near the starter motor

Electrical characteristics:

- Side Stand Up: closed circuit (continuity)



- Side Stand Down: open circuit (infinite resistance)

Pin-out:

- Blue green (cable harness side): ground connection
- Grey yellow (cable harness side): Voltage 12V

Troubleshooting

- The vehicle with clutch pulled, gear engaged and side stand retracted does not start (side stand switch always open): verify continuity of the grey/yellow cable between the sensor and PIN 19 of the control unit.
- If absent, restore the cable harness, if present, with the stand up, check for continuity between the 2 PINS on the sensor. If absent, replace the sensor. If present, check for continuity to ground of the blue/green cable on the cable harness side connector.
- The vehicle, with clutch operated and gear engaged, starts but with the side stand extended: disconnect the sensor connector and check that, with side stand extended, there is not continuity between the 2 PINS.
- If present, replace the sensor. If absent, disconnect from control unit PIN 19 and check insulation from the ground of the grey/yellow cable between sensor and control unit.

Air temperature sensor - instrument panel

Function

It tells the ambient air temperature to the instrument panel.

Operation / Operating principle

NTC type sensor (resistance sensor, inversely variable with temperature).

Level in electrical circuit diagram: Temperature sensors

Location:

- under instrument panel supporting bracket
- connector: under the start-up lock

Electrical characteristics:

- Resistance at 0°C: 32.5 kOhm +/- 5%
- Resistance at 25°C: 10.0 kOhm +/- 5%

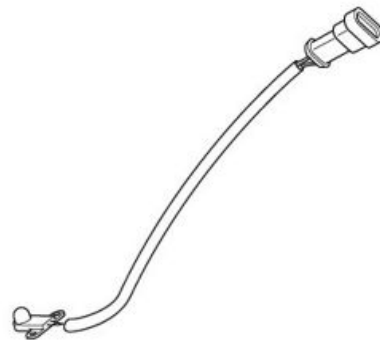

Pin-out:

1. Voltage 5V (pink cable)
2. Ground (blue cable)

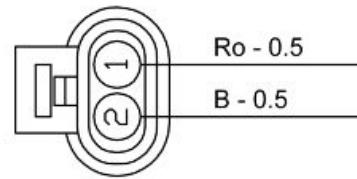
**Air temperature sensor fault**Error cause

- An instrument panel temperature sensor failure is signalled when it is detected that the sensor circuit is open or shorted to positive/negative

Troubleshooting

- Check the sensor connector and the instrument panel connector (PIN 12):
- Restore if not OK.
- If OK check continuity of pink cable between the sensor connector (cable harness side) and PIN 12 of the instrument panel connector.
- If there is no continuity, restore the cabling.
- If there is continuity check correct resistance of the sensor:
- If the sensor resistance is not OK replace the sensor.
- If OK check, with the key turned ON, for the presence of voltage at sensor connector PIN 1:
- If there is no voltage at PIN 1 replace the instrument panel.
- If about 12 V is present, restore the cabling (there is a short to battery).
- If about 5 V is present, connect a 10 kOhm resistance to PIN 1 of the sensor connector and the vehicle ground.
- If, with the key ON, the voltage measured upstream of the resistance drops, replace the instrument panel. If it continues to stay at about 5 V restore the pink cable (there is a short to + 5V).

- In case there is a short circuit to ground connection of PIN 12 of the instrument panel connector:
- Check the ground insulation of the sensor connector pink cable:
- If connected to ground, restore the cabling. If insulated from ground, check correct resistance of the sensor:
- if not OK, replace the sensor; if OK, replace the instrument panel

RUN/STOP switch

Function

It tells the control unit if the rider wishes to enable engine start-up or to keep the engine running.

Operation / Operating principle

If the driver wants to shut off the engine or to disable engine start-up, the switch should be open, i.e. the Marelli control unit should not detect voltage at PIN 26 of the control unit connector.



Level in electrical circuit diagram: start-up enabling switches.

Location:

- sensor: right light switch
- connector: next to the headstock, right side

Electrical characteristics:

- STOP position: the circuit is open
- RUN position: closed circuit (continuity)

PIN:

pink/yellow cable (looking at the cabling):

- voltage 0 V with engine kill in STOP;
- 12V if engine kill in RUN.

Blue/Green cable (cable harness side): always voltage 12 V (with key on)

DIAGNOSIS

- The engine does not start: disconnect the connector and check, with the switch set to RUN, that there is continuity between the two grey/light blue and red/white cables (sensor side): if absent replace the sensor; if present carry out the check procedure on the connector; if not OK restore the cabling; if OK verify, with the key ON, the presence of voltage on the blue/green cable (cable harness side); if absent, restore cabling; if present verify insulation

from ground of the red/yellow cable (cable harness side). If there is continuity with ground connection, restore the cable harness; if it is OK, set the key to KEY OFF and check the control unit connector; if it is OK, replace the Marelli control unit

- Engine does not shut off with switch in "STOP": disconnect the connector and verify, with the switch set to STOP, that there is continuity between the two grey/light blue and red/white cables (sensor side). If present, replace the switch; if absent this means that, with the key ON, the pink/yellow cable shorts to positive: restore the cable harness. If cable harness is OK, replace the Marelli control unit

Connectors

ECU

PIN:

1. Throttle position sensor supply - Power output
2. Lambda probe signal (ground) - Analogue input
3. Rpm indicator control - Frequency output
4. Cylinder head temperature sensor signal - Analogue input
5. -
6. Right injector control - Power output
7. Engine revolution sensor - Frequency input
8. Lambda probe signal (positive) - Analogue input
9. Diagnosis line (K) - Communication line
10. Diagnosis line (L) - Communication line
11. Throttle position signal - Analogue input
12. Engine revolution sensor - Frequency input
13. Right injector control - Power output
14. Right coil control - Power output
15. Injection telltale light control - Digital output
16. Fall sensor signal - Digital input
17. Control unit supply - Power input
18. Intake air temperature sensor signal - Analogue input
19. Injection relay control - Digital output

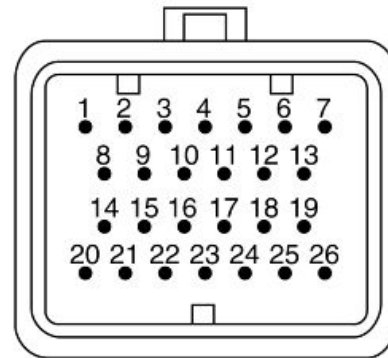

- 20. Left coil control - Power output
 - 21. -
 - 22. Sensors supply (ground) - Power output
 - 23. Control unit supply (ground) - Power input
 - 24. Control unit supply (ground) - Power input
 - 25. -
 - 26. Control unit supply (+15) - Power input
-

Dashboard

PIN:

- 1. Right arrow input
- 2. Set rework input
- 3. High-beam lights input
- 4. n.c.
- 5. n.c.
- 6. Rear left arrow output
- 7. Front left arrow output
- 8. EFI input
- 9. Left arrow input
- 10. Neutral input
- 11. Oil input
- 12. Air temperature input
- 13. Speed sensor power supply
- 14. Ground connection
- 15. K Line
- 16. n.c.
- 17. Speed input
- 18. Engine revs input
- 19. n.c.
- 20. Reserve input
- 21. Key
- 22. Ground connection
- 23. Battery
- 24. Front right arrow output
- 25. Rear right arrow output
- 26. Battery

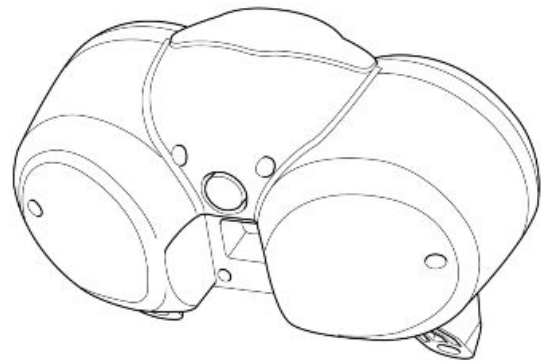

INDEX OF TOPICS

ENGINE FROM VEHICLE

ENG VE

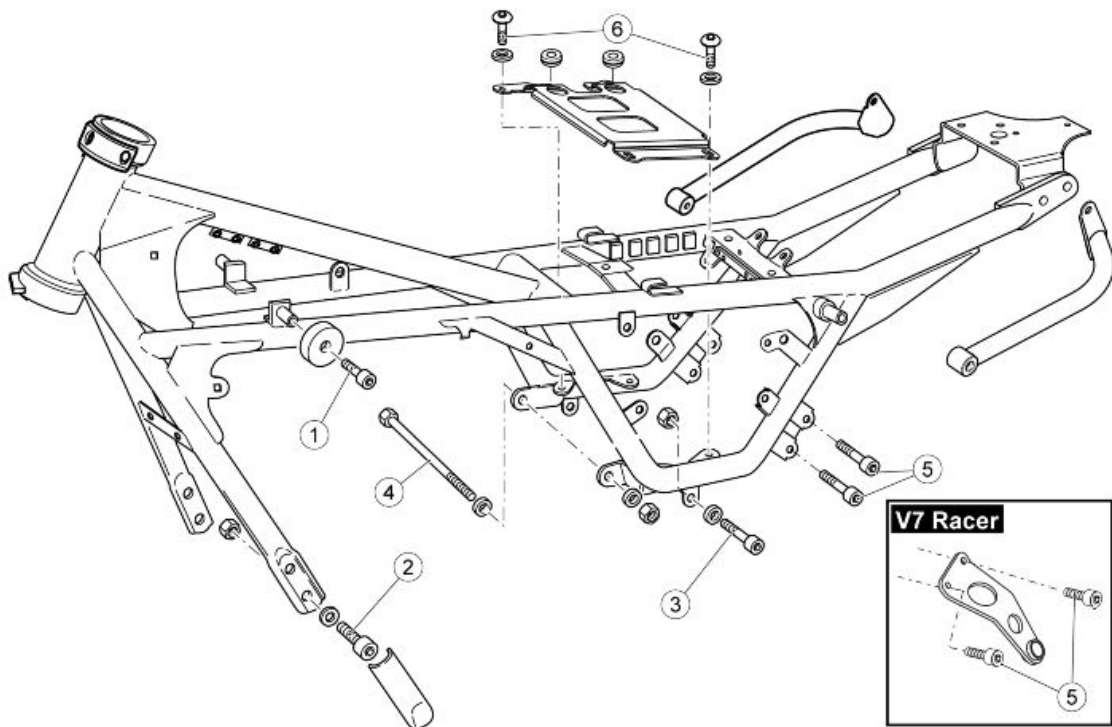

FRAME

pos.	Description	Type	Quantity	Torque	Notes
1	Screw fixing tank mounting rubber blocks to frame	M8x14	2	25 Nm (18.44 lbf ft)	-
2	Cradle front fixing screw	M10x30	4	50 Nm (36.88 lbf ft)	-
3	Screw fastening gearbox to frame	M10x55	2	50 Nm (36.88 lbf ft)	-
4	Pin fixing engine/gearbox to chassis	M10x205	1	50 Nm (36.88 lbf ft)	-
5	Screw fixing exhaust silencer mounting to frame	M8x16	4	25 Nm (18.44 lbf ft)	Loctite 243
6	Battery supporting plate fixing screw	M8x16	4	25 Nm (18.44 lbf ft)	-

Vehicle preparation

- To arrange for the removal of the engine block, you must first remove the saddle, fuel tank, side fairings and the battery
- From the front, secure the vehicle with belts attached to a hoist
- Position a centre stand under the engine sump
- Position an engine support so as not to damage the rubber bellows of the drive shaft

See also

[Side body panels](#)

Fuel tank

[Specific operations for the vehicle](#)

Removing the engine from the vehicle

- Remove the spark plug covers



- Disconnect the caps from the spark plugs



- Remove the timing sensor fixing screws.
- Remove the sensor, being careful to recover the gasket.



- Disconnect the alternator connector



- Remove the fixing screws of the injectors and disconnect them



- Disconnect the engine temperature sensor connector



- Loosen the clamps securing the sleeve and remove it



- Disconnect the oil pressure bulb connector



- Remove the fixing screw of the engine ground wires



- Disconnect the clutch cable from the lever



- Disconnect the clutch cable from the disengagement lever



- Pass the rear brake fluid reservoir through the hole on the support of the backing plate.
- Secure the rear brake oil reservoir

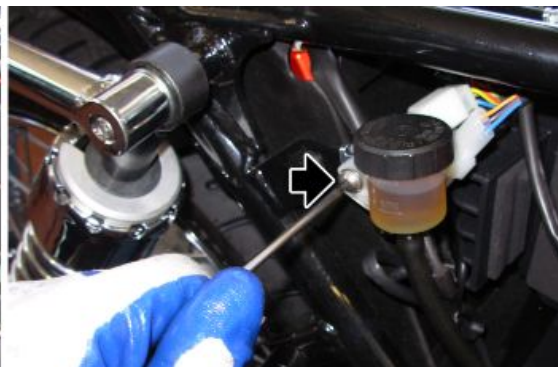

- Secure the filter box to the frame

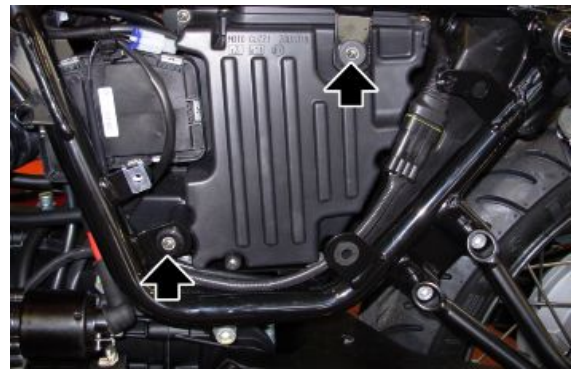

- Remove the rear brake fluid reservoir fixing screw
- Pass the rear brake fluid reservoir through the hole on the support plate bracket.



- Remove the screws which fix the air filter box to the frame

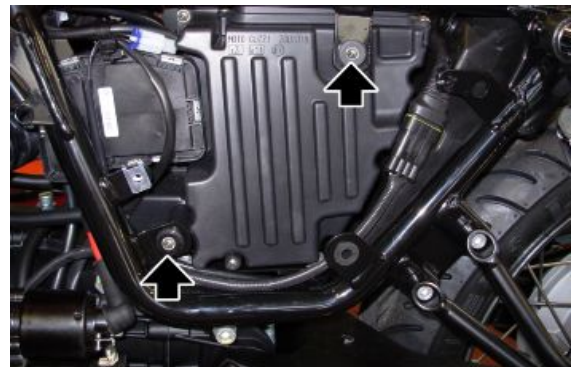

- Disconnect the neutral sensor connector.
- Lift the filter box and slide the cabling out through the support plate



- After removing the clamp, disconnect the speed sensor and rear stop

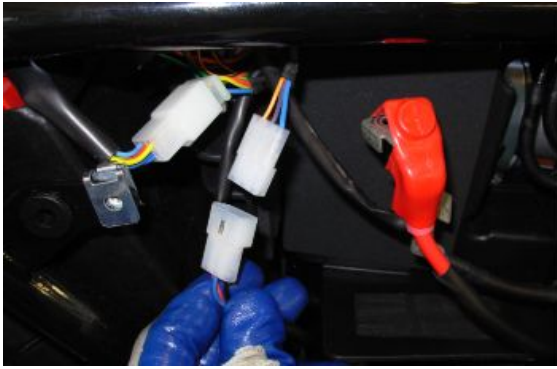

- Disconnect the side stand switch connector



- Remove the cradle fixing screws guards



- Remove the screws fixing the cradle, making sure to recover the nuts and washers

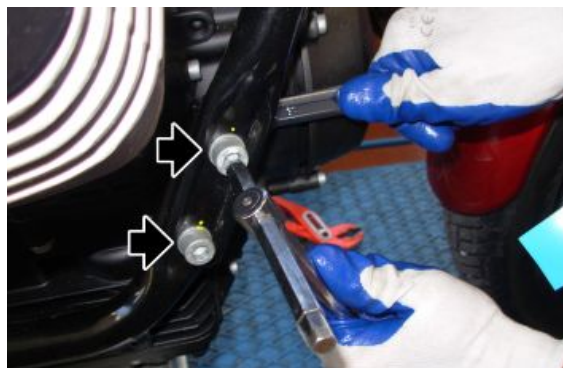

- Remove the central pin by pulling it from the right side of the motorcycle

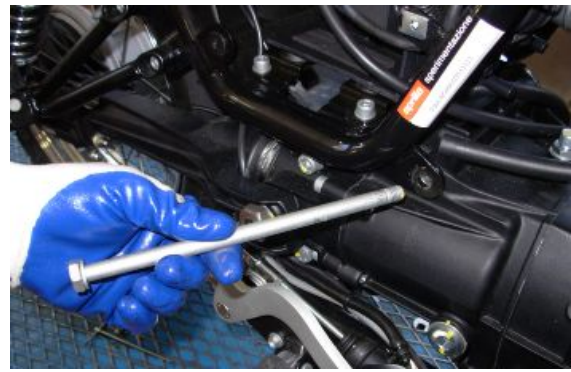

- Remove the fixing pin of the rear left shock absorber



- Remove the screw fixing the right-hand rear right shock absorber and pull it from the pin on the drive shaft

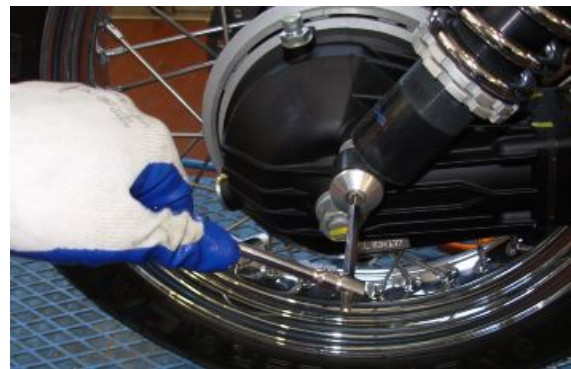

- Remove the side pins, taking care to recover the nuts



- Lift the frame and separate it from the engine block



Installing the engine to the vehicle

- Place the frame on the engine block



- Insert the central pin from the right side of the motorcycle, place the washer and the nut from the opposite side



- Insert the side pins and their retainer nuts



- Insert the screws with the relative re-tainer nuts and washers of the cradles to the frame

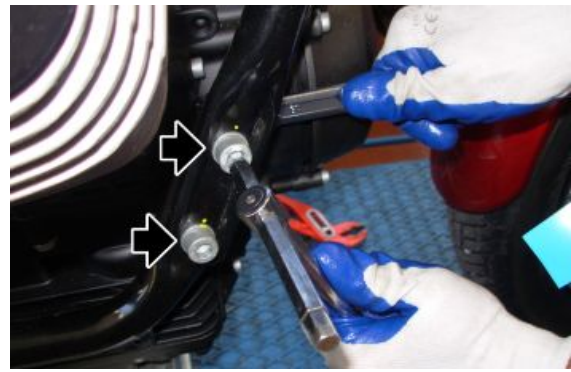

- Tighten the fixing screws of the cradle to the prescribed torque, the central pin and the side pins of the engine to the frame
- Install the protections of the fixing screws of the cradles



- Insert the right rear shock absorber on the pin and secure it

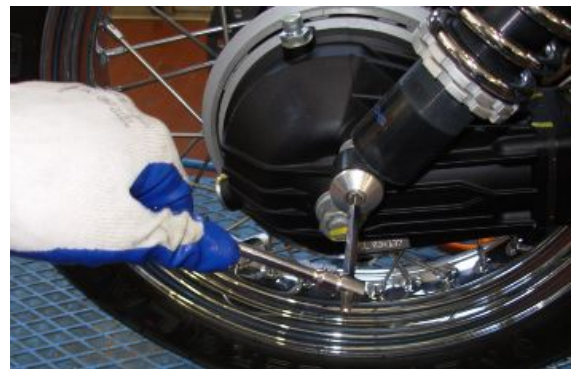

- Attach the rear left shock absorber via the appropriate pin with corresponding nut



- Connect the side stand switch connector



- Lift the filter box and thread the cable through the backing plate
- Connect the neutral sensor connector



- Connect the speed sensor and rear stop

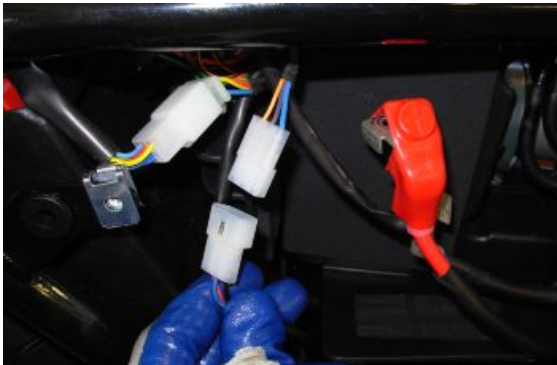

- Connect the clutch cable to the trip lever



- Connect the clutch cable to the lever



- Install the sleeve, paying attention to the correct positioning of the clamps before tightening them



- Connect the oil pressure bulb connector



- Attach the engine ground leads



- Connect the engine temperature sensor connector



- Connect and secure the injectors



- Install the timing sensor with its seal



- Connect the alternator connector



-
- Connect the spark plug tubes



-
- Install the covers of the spark plugs



INDEX OF TOPICS

POWER SUPPLY

P SUPP

Circuit diagram

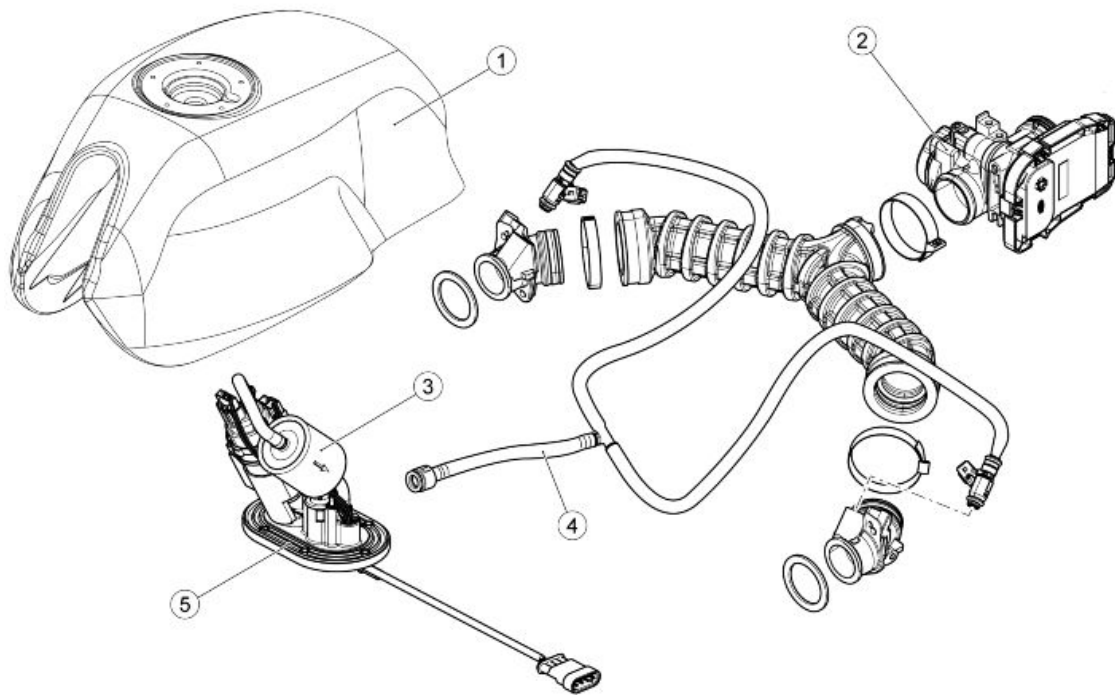

Key:

- 1. Fuel tank
- 2. Throttle body
- 3. Fuel filter
- 4. Fuel delivery pipe
- 5. Fuel pump unit

Injection

Diagram

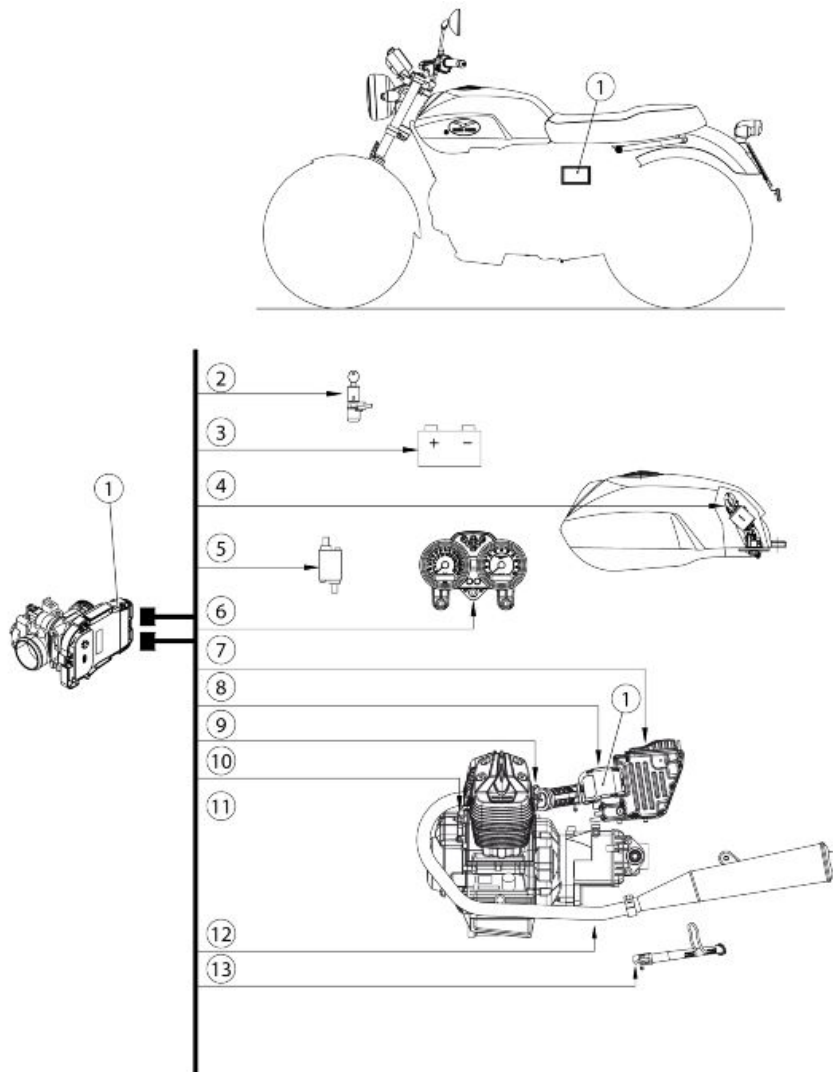
**key:**

1. Control unit position
2. Ignition switch
3. Battery
4. Fuel pump
5. Coils
6. Instrument panel
7. Air temperature sensor
8. Throttle valve position sensor
9. Injectors
10. Crankshaft position sensor
11. Engine temperature sensor
12. Lambda probe

13.Side stand

ECU INFO screen page

This screen page shows general data regarding the control unit, for example software type, mapping, control unit programming date



INFO ECU SCREEN PAGE

Specification	Desc./Quantity
Mapping	-

Using P.A.D.S. for injection system

INDEX OF TOPICS

SUSPENSIONS

SUSP

Front

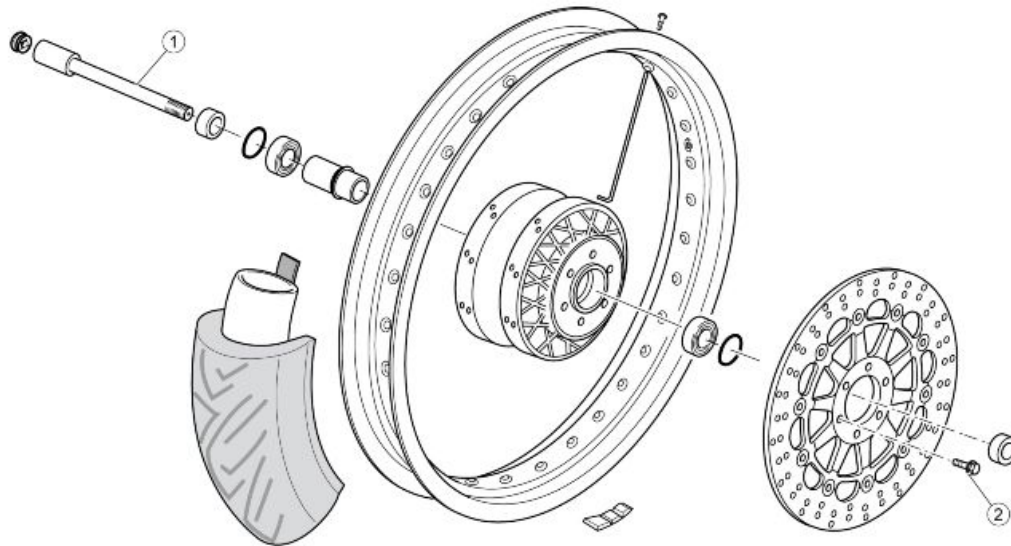

FRONT WHEEL

pos.	Description	Type	Quantity	Torque	Notes
1	Front wheel axle	M18x1.5	1	80 Nm (59.00 lbf ft)	-
2	Front brake disc fixing screw	M8x20	6	25 Nm (18.44 lbf ft)	Loctite 243

Removing the front wheel

- Place the vehicle on a stable support so that the front wheel does not touch the ground.
- Remove the brake calliper without disconnecting the oil pipes



- Remove the front wheel.

Handlebar

(V7 SPECIAL / V7 STONE)

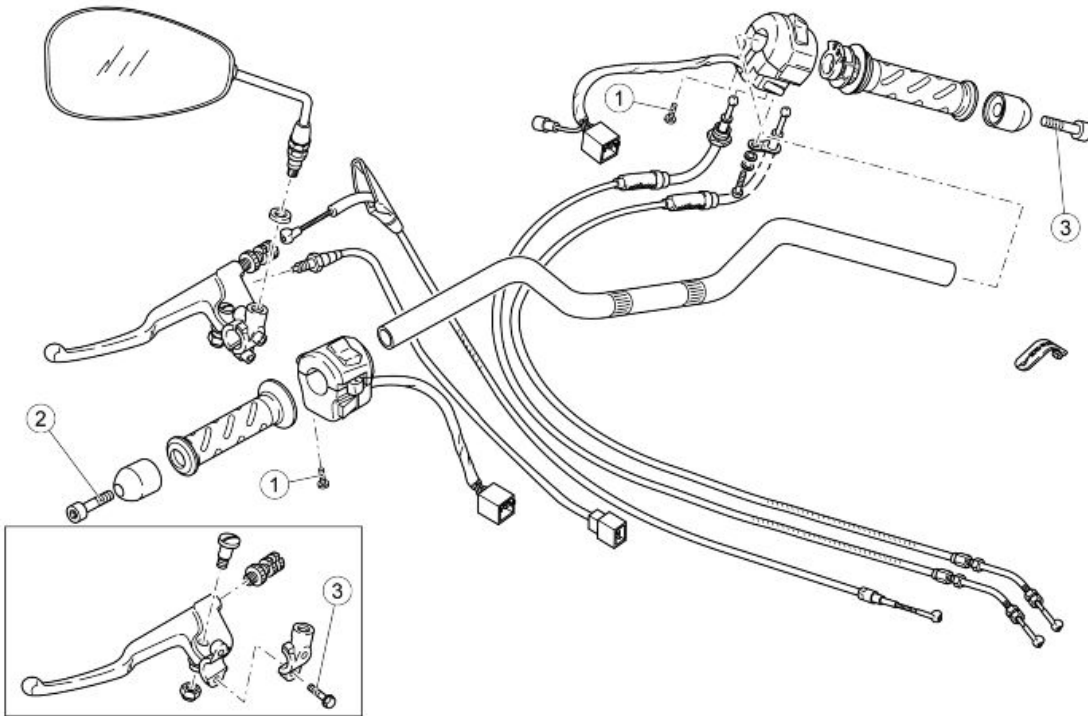

HANDLEBAR AND CONTROLS

Pos.	Description	Type	Quantity	Torque	Notes
1	Switch fastener screw	SWP 5	1+1	1.5 Nm (1.11 lb ft)	-
2	Counterweight fixing screw	M6	2	10 Nm (7.37 lb ft)	Loctite 243
3	Screw fastening the clutch control U-bolt to the semi-handlebar	M6x25	2	10 Nm (7.37 lb ft)	-

(V7 RACER)

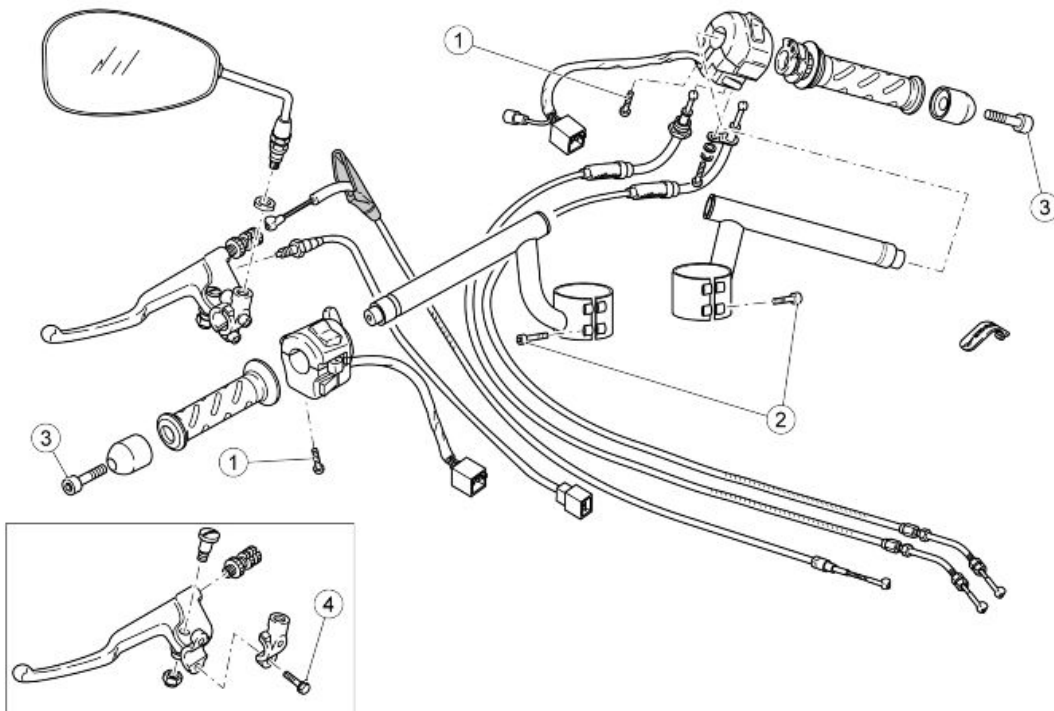

HANDLEBAR AND CONTROLS

Pos.	Description	Type	Quantity	Torque	Notes
1	Switch fastener screw	M5	1+1	1.5 Nm (1.11 lb ft)	Tighten using a 1-2-1 sequence
2	Semi-handlebar fixing screw	M6x25	4	10 Nm (7.37 lb ft)	Tighten using a 1-2-1 sequence
3	Counterweight fixing screw	M6	2	10 Nm (7.37 lb ft)	Loctite 243
4	Screw fastening the clutch control U-bolt to the semi-handlebar	M6x25	2	10 Nm (7.37 lb ft)	Tighten using a 1-2-1 sequence

Front fork

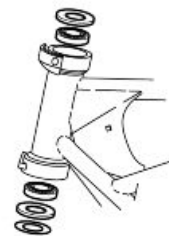
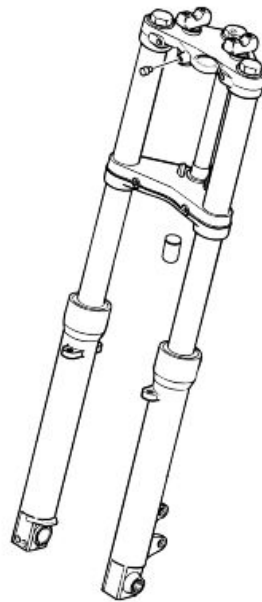
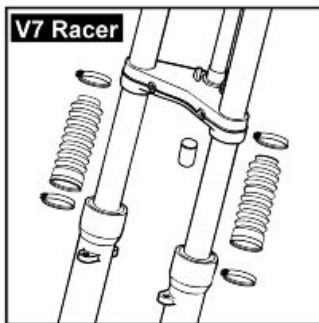
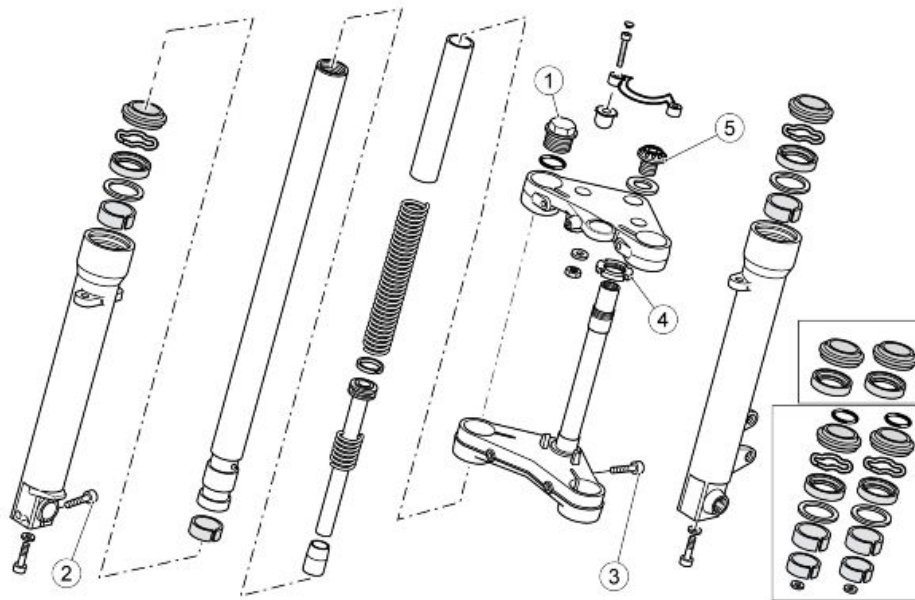

FRONT SUSPENSION - STEERING

pos.	Description	Type	Quantity	Torque	Notes
1	Stanchion cap	-	2	50 Nm (36.88 lbf ft)	-
2	Screw fixing wheel axle to right fork leg	M6x30	2	10 Nm (7.37 lbf ft)	Tighten using a 1-2-1 sequence
3	Screw fixing stanchions to upper and lower plate	M10x40	4	50 Nm (36.88 lbf ft)	-
4	Headstock ring nut	M25x1	1	7 Nm (5.16 lbf ft)	The fork must fall to one side by itself

pos.	Description	Type	Quantity	Torque	Notes
5	Headstock bushing	M23x1	1	50 Nm (36.88 lbf ft)	-

Diagram

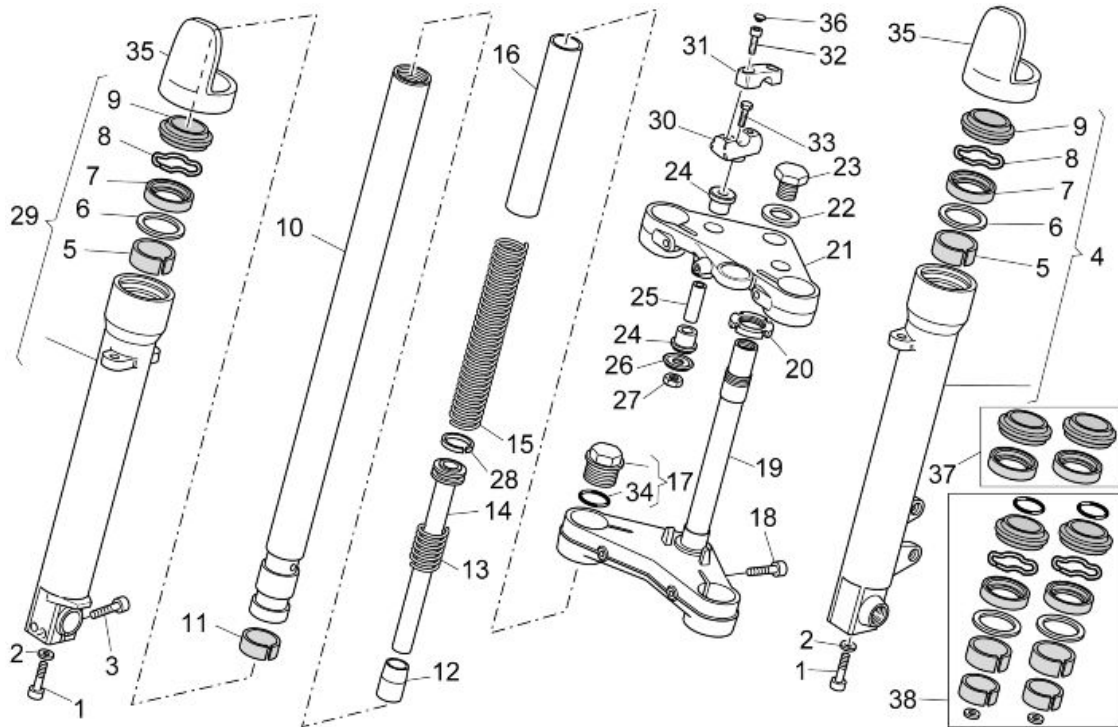

Key:

1. Screw
2. Washer
3. Screw
4. Complete left sleeve
5. Upper bushing
6. Washer
7. Sealing ring
8. Snap ring
9. Dust guard
10. Stem
11. Lower bushing
12. Buffer
13. Counter spring
14. Complete pumping member
15. Spring
16. Pipe
17. Complete cap

- 18.Screw
- 19.Base with headstock
- 20.Ring nut
- 21.Fork upper plate
- 22.Washer
- 23.Nut
- 24.Rubber ring
- 25.Spacer
- 26.Cap
- 27.Nut
- 28.Ring
- 29.Complete right sleeve
- 30.Lower U-bolt
- 31.Upper U-bolt
- 32.Screw
- 33.Screw
- 34.O-ring
- 35.Stem protection
- 36.Chrome-plated cap
- 37.Gasket kit
- 38.Oil seal kit

Removing the fork legs

NOTE



PAY ATTENTION TO THE TYPE OF FORK FITTED DURING REMOVAL AND FITTING. TWO DIFFERENT SUPPLIES CAN BE FOUND ON THIS MOTORCYCLE, MARZOCCHI OR KAIFA. TO DISTINGUISH BETWEEN THEM IT IS NECESSARY TO PROCEED WITH THE REMOVAL. THE MARZOCCHI FORK, UNLIKE THE KAIFA ONE IS EQUIPPED WITH A WASHER ABOVE THE PRELOAD TUBE AND A SHIM HOUSED BELOW.



The vehicle is equipped with a non adjustable fork. The operations described below are valid for both stanchions.

CAUTION

DURING THE OPERATIONS DESCRIBED BELOW, THE STANCHIONS AND THEIR INTERNAL COMPONENTS SHOULD BE TIGHTENED ON A VICE. MAKE SURE NOT TO DAMAGE THEM BY OVERTIGHTENING; ALWAYS USE ALUMINIUM JAW CAPS.

- Remove the front wheel.

- Remove the front mudguard.



- Undo and remove the two screws and collect the washers.



- Move the instrument panel forwards.

- Undo the upper sealing screw.



- Undo the lower sealing screw.



- Slide off the stem downwards by turning it slightly first in one direction then to the opposite direction.

Draining oil

To drain out the oil follow these steps.

- Remove the stanchion.
- Tighten the removed stanchion in a vice fitted with aluminium jaw caps in order to avoid damaging them.

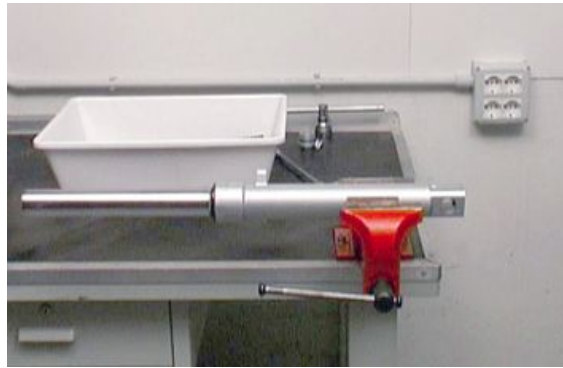

- Unscrew the upper closing cap. Pay attention to the possible thrust that the spring can cause to the loosened cap.



KAIFA FORK PROCEDURE

- Be careful not to damage the O-Ring during extraction.
- Press the bearing tube inside the wheel holder fork leg.
- Remove the preload tube and the spring.



MARZOCCHI FORK PROCEDURE

- Be careful not to damage the O-Ring during extraction.
- Remove the washer.
- Press the bearing tube inside the wheel holder fork leg.
- Remove the preload tube and the spring.



- Remove the shim.



- Drain out all the oil inside the stanchion.

NOTE

FOR EASY DRAINAGE OF THE OIL INSIDE THE PISTON ROD, PRESS THE STANCHION IN THE WHEEL HOLDER SLEEVE TO PUMP OIL OUT.



- Carefully check each part of the stanchion and make sure that there are no damaged elements.
- If there are no damaged or worn elements, refit the stanchion; otherwise, replace the damaged elements.

NOTE

FOR EASY DRAINAGE OF THE OIL INSIDE THE PISTON ROD, PRESS THE STANCHION IN THE WHEEL HOLDER SLEEVE TO PUMP OIL OUT.



Disassembling the fork

- Drain all the oil from the stem.
- Block the wheel holder fork leg on the vice.
- Undo the bottom screw and remove it with the corresponding gasket.



- Remove the dust scraper using a screwdriver as a lever.

CAUTION

BE CAREFUL NOT TO DAMAGE THE FORK LEG RIM AND THE DUST SCRAPER.



- Slide the dust scraper off and upwards.



- Remove the locking ring inside the fork leg using a thin screwdriver.

CAUTION

BE CAREFUL NOT TO DAMAGE THE FORK LEG RIM.



- Slide off the bearing tube from the wheel holder fork leg together with the sealing ring, the cap, the upper bushing and lower bushings.

NOTE

WHEN REMOVING THE PIPE FROM THE WHEEL HOLDER FORK LEG SOME PARTS MAY REMAIN INSIDE THE FORK LEG. IF THIS OCCURS, THESE PARTS MUST BE REMOVED AFTERWARDS, BEING CAREFUL NOT TO DAMAGE THE FORK LEG RIM AND THE UPPER BUSHING SEAT



Checking the components

- Check every component removed from the fork leg, specially: the sealing ring and the dust guard as they are elements that guarantee sealing; replace them if some of them are damaged.
- Check the bushing on the bearing tube; remove it and replace it if damaged or worn.
- Slide off the pumping member unit from the holding tube; if it is damaged, replace the counter spring and the ring.



Reassembling the fork

CAUTION

ALL COMPONENTS MUST BE CAREFULLY WASHED AND DRIED WITH COMPRESSED AIR BEFORE REFITTING.

- Carry out any necessary service operation.
- Insert the pumping member unit with the counter spring and the ring in the bearing tube.



- Check that the upper guide bushing is fitted on the wheel holder fork leg.

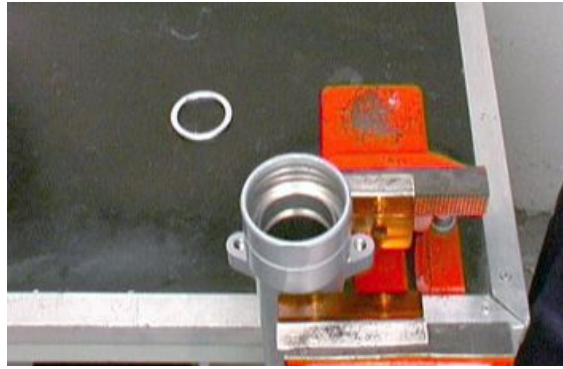

- Insert the lower sliding bushing in its seat on the bearing tube.



- Reassemble the bearing tube in the wheel holder fork leg.



- Insert the bearing tube in the wheel holder and push it until it stops.



- Screw the bottom screw and tighten it to the prescribed torque.

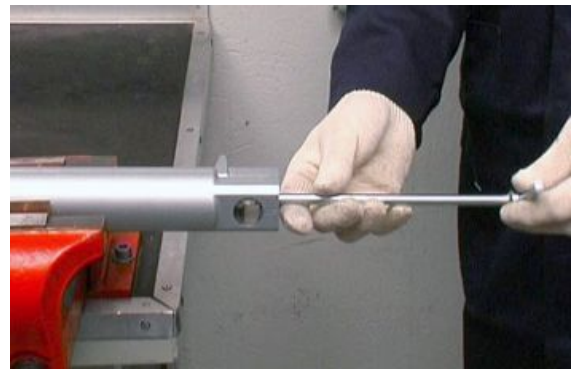

- Insert the cap and the well-lubricated sealing ring on the bearing tube.
- Use a suitable inserting tool to push the sealing ring in the fork leg until it stops.



- Fit the locking ring.



- Fit the dust scraper.
- Pour oil into the bearing tube so that it also fills the internal grooves of the pumping member rod.
- Pump with the bearing tube, making sure the oil has completely filled the pumping member rod.
- Introduce the spring and the preload tube.
- Place the cap on the bearing tube, taking care not to damage the O-ring. Then, tighten the cap to the prescribed torque.



Filling oil

- Place the sleeve upright in a vice fitted with protection jaws.
- Compress the sleeve in the stanchion.
- Pour part of the fork oil into the sleeve.
- Wait some minutes until the oil fills all the ducts.
- Pour the remaining oil.
- Pump out oil a few times.
- Measure the air gap between the oil level and the rim.

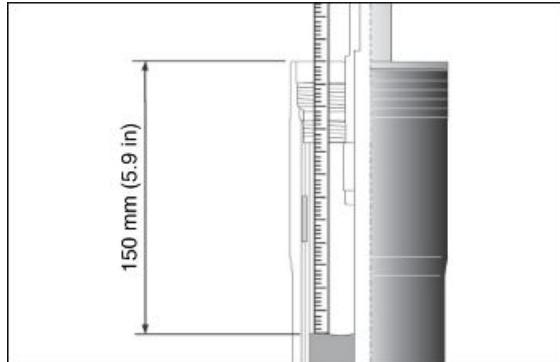

THE SLEEVE MUST BE PERFECTLY UPRIGHT IN ORDER TO MEASURE THE CORRECT OIL LEVEL. THE OIL LEVEL MUST BE THE SAME IN BOTH STANCHIONS.

Characteristic

Marzocchi Oil level (from the sleeve edge, without the spring and with stanchion to end of stroke)

150 mm (5.9 in)

Kaifa Oil level (from the sleeve edge, without the spring and with stanchion to end of stroke)

120 +/- 1.5 mm (4.72 +/- 0.06 in)

- Introduce the spring and the preload tube.





- Place the cap on the bearing tube, taking care not to damage the O-ring.



- Then, tighten the cap to the prescribed torque.



Installing the fork legs

- Insert the stem on the vehicle going through the lower plate and the upper plate.
- Tighten the screws to the prescribed torque.





Steering bearing

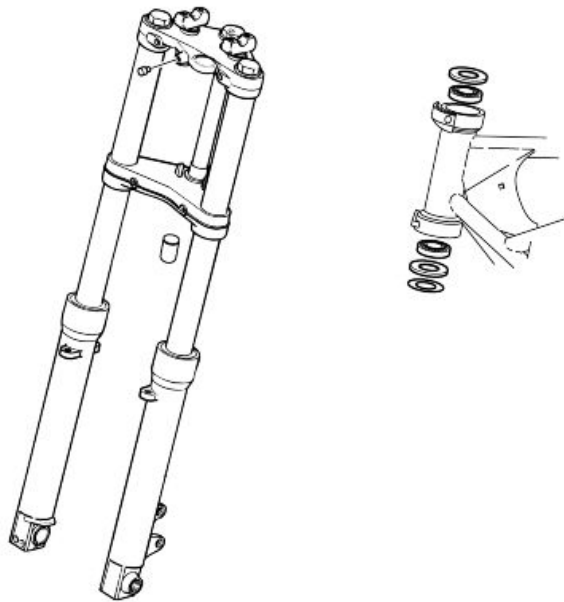
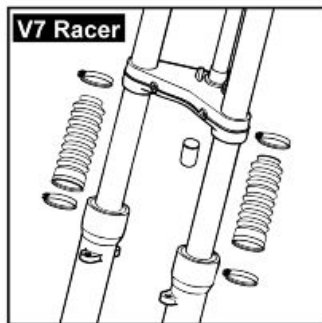
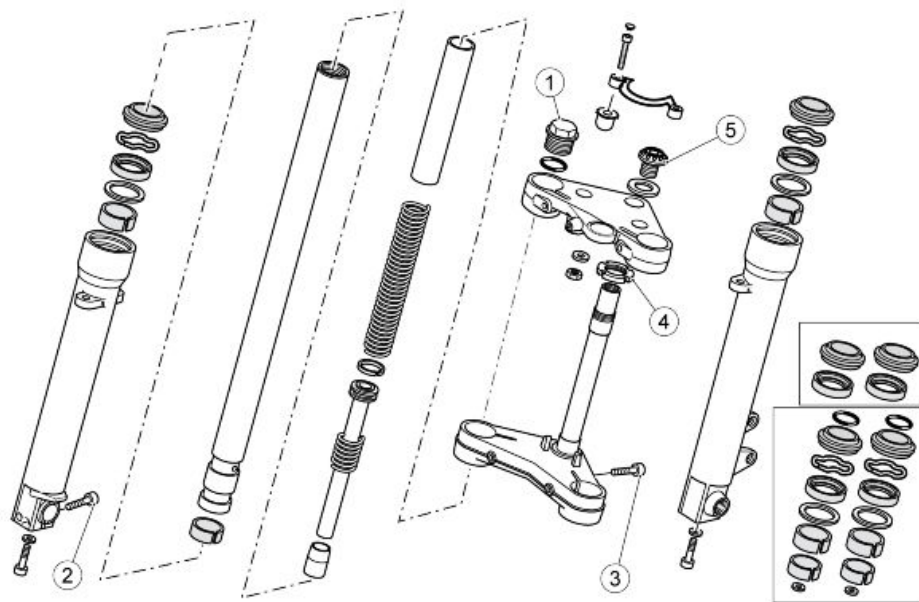

FRONT SUSPENSION - STEERING

pos.	Description	Type	Quantity	Torque	Notes
1	Stanchion cap	-	2	50 Nm (36.88 lbf ft)	-
2	Screw fixing wheel axle to right fork leg	M6x30	2	10 Nm (7.37 lbf ft)	Tighten using a 1-2-1 sequence
3	Screw fixing stanchions to upper and lower plate	M10x40	4	50 Nm (36.88 lbf ft)	-
4	Headstock ring nut	M25x1	1	7 Nm (5.16 lbf ft)	The fork must fall to one side by itself

pos.	Description	Type	Quantity	Torque	Notes
5	Headstock bushing	M23x1	1	50 Nm (36.88 lbf ft)	-

Adjusting play

- Undo and remove the screws and collect the U-bolt, holding the handlebar.
- Move the handlebar forward, be careful not to turn over the front brake fluid reservoir.
- Remove the instrument panel.



- Working from both sides, undo and remove the screw locking the upper plate to the front fork.



- Unscrew and remove the central nut.



- Remove the upper plate from the front fork.



- Adjust the ring nut.
- Fit the upper plate on the front fork.



- Tighten the central nut.



- Working from both sides, tighten the screw locking the upper plate to the front fork.
- Fit the handlebar.
- Fit the instrument panel.

Rear

Shock absorbers

(V7 SPECIAL / V7 STONE)

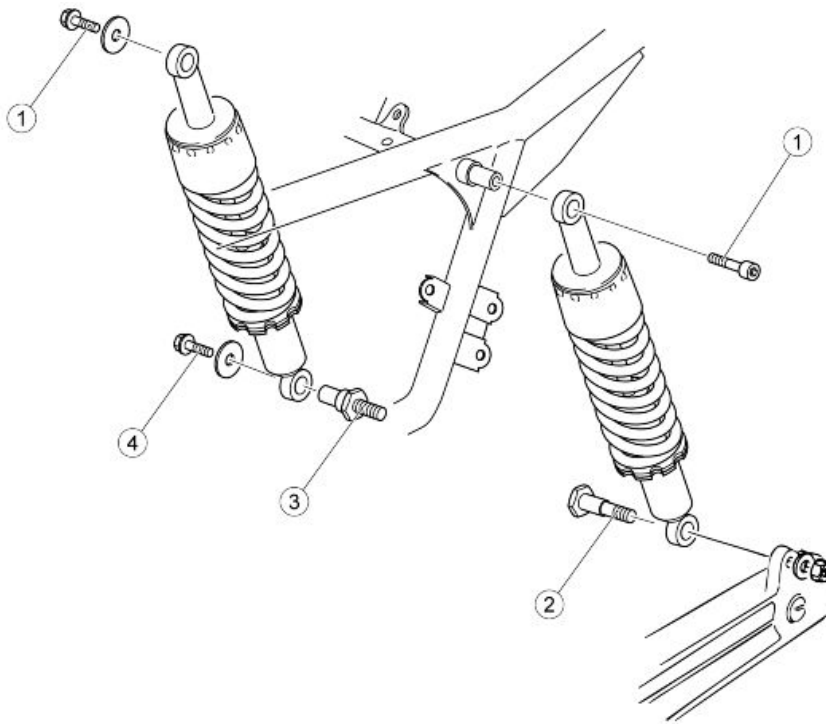

(V7 RACER)

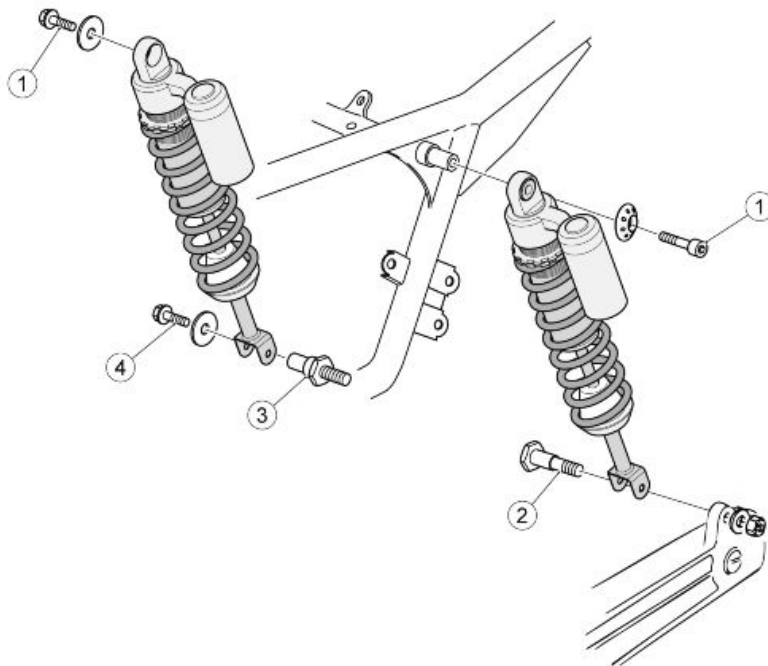

REAR SUSPENSION

pos.	Description	Type	Quantity	Torque	Notes
1	Upper screw fastening shock absorber to frame	M6x35	2	10 Nm (7.37 lbf ft)	Loctite 243
2	Lower pin fastening left shock absorber to swingarm	M10x1.5	1	35 Nm (25.81 lbf ft)	

pos.	Description	Type	Quantity	Torque	Notes
3	Stud bolt fixing right shock absorber to rear box	M12x1.5	1	35 Nm (25.81 lbf ft)	-
4	Screw fastening right shock absorber to stud bolt	M6x16	1	10 Nm (7.37 lbf ft)	Loctite 243

Removing

- Undo and remove the upper screw.



- Undo and remove the lower screw.



INDEX OF TOPICS

CHASSIS

CHAS

Swinging arm

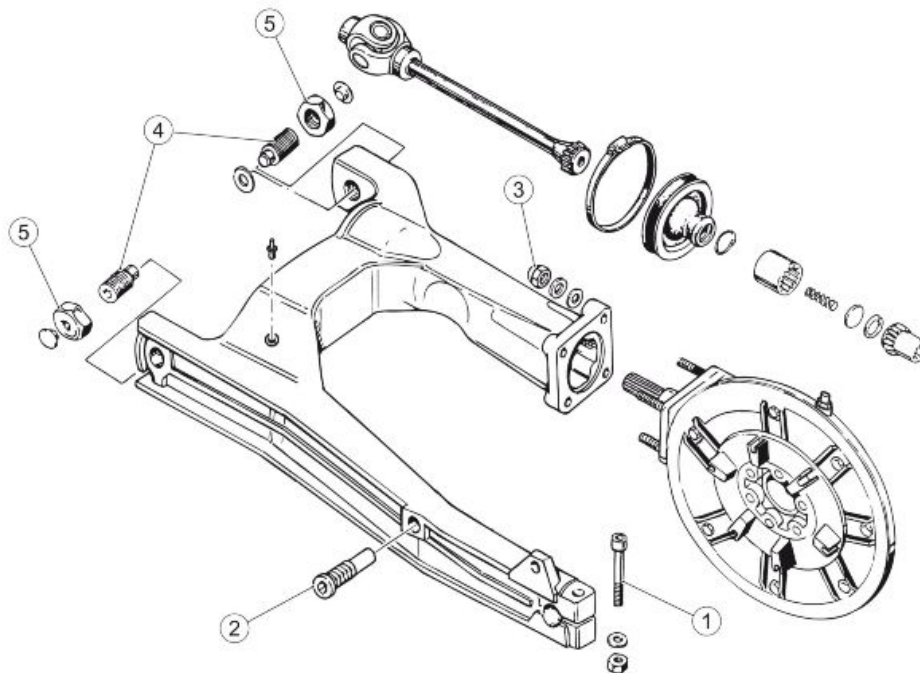

REAR TRANSMISSION - SWINGARM

pos.	Description	Type	Quantity	Torque	Notes
1	Swingarm clamp retaining screw	M10x45	1	30 Nm (22.13 lbf ft)	-
2	Pin fixing the rear calliper holding plate to swingarm	M16x1	1	25 Nm (18.44 lbf ft)	-
3	Nut fixing gearcase to swingarm	M8	4	25 Nm (18.44 lbf ft)	Hold the stud bolt
4	Pin fixing swingarm to gearbox	M20x1	2	-	Fully home with no preload
5	Lock nut on swingarm pin	M20x1	2	50 Nm (36.88 lbf ft)	Hold the pin

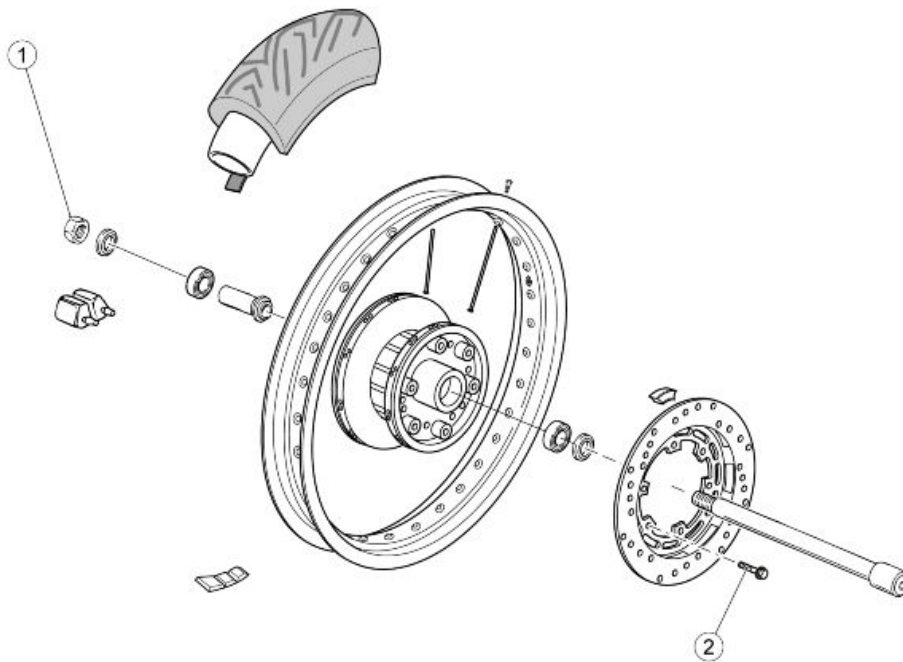
**REAR WHEEL**

pos.	Description	Type	Quantity	Torque	Notes
1	Rear wheel axle nut	M16x1.5	1	120 Nm (88.51 lb ft)	-
2	Rear brake disc fixing screw	M8x25	6	25 Nm (18.44 lb ft)	Loctite 243

Removing

- Remove the left silencer.



- Remove the rear calliper, releasing the brake pipe from the retainers on the swingarm.



- Unscrew and remove the fixing screw of the calliper holder.



- Remove both rear suspensions.



- Unscrew and remove the nut and collect the washer.



- Loosen the wheel pin locking screw.

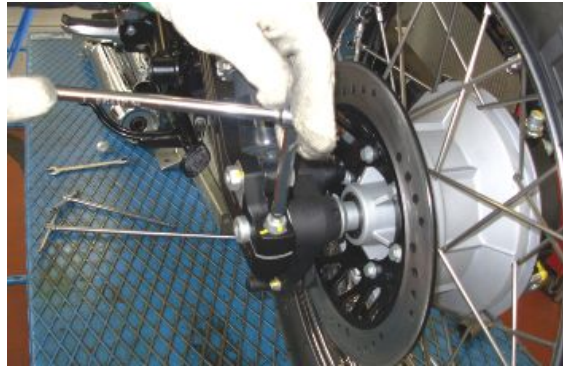

- Remove the wheel pin and collect the spacer.



- Remove the rear wheel.



- Unscrew the seal clamp.
- Lift the bellows.



- Unscrew the nuts.



- Loosen the pins so that the oscillating swingarm can be removed from the gearbox.



- Remove the shimming washer between the swingarm right arm and the gearbox.



Checking

- Check that the universal joint is not damaged, the gear teeth inserting in the sleeve grooves and the grooves on the joint are not deformed or damaged; otherwise, replace the joint.
- Check that the rubber bellows are not cut or pierced; otherwise, replace it.
- Check that the swingarm pin threads and the swingarm fixing nuts are not damaged, deformed or flattened; otherwise, replace them.
- Check that the sleeve grooves are not damaged, deformed or deteriorated; otherwise, replace the sleeve.
- Check that the spring is not deformed; otherwise, replace it.
- Check that the sealing ring (Seeger) is still flexible and is not deformed.
- Check that the sleeve outer tothing and internal grooves are not damaged.

Installing

- Insert the swingarm on the gearbox cover.
- Tighten thoroughly the pin on the left side until the shimming washer on the right side rests on the bearing fitted on the gearbox cover.



- Tighten thoroughly the pin on the right side, without locking it.
- Operate the swingarm and make sure it oscillates freely without clearance.



- Screw in the lock nuts on the pins, locking them thoroughly.



- Screw the clamp.



- Fit the rear wheel.



Bevel gears

Removing

- Undo the four nuts and collect the washers.



- Slide off the gearcase together with the swingarm.



- Slide off the sleeve from the pinion.
- Slide off the spring.
- Slide off the sealing ring.
- Slide off the base.

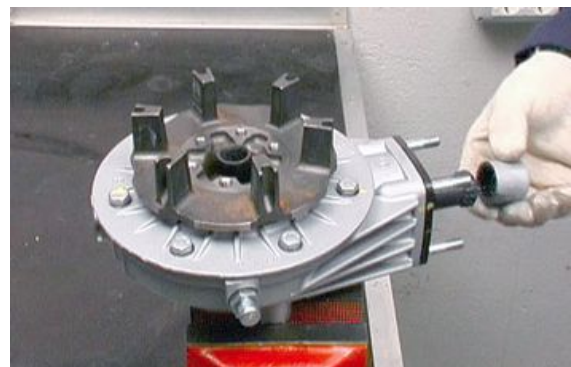

- Slide off the gear.

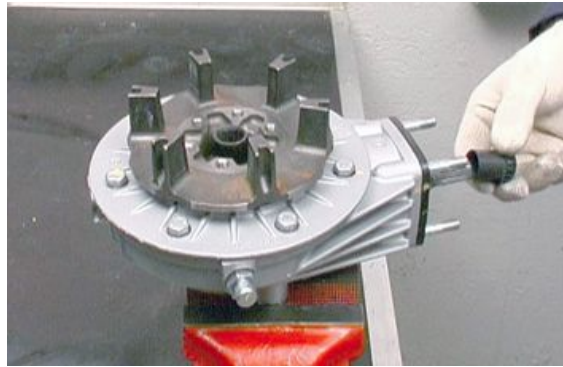

Checking

Gruppo pignone

- Remove the housing of the swingarm .
- Slide the complete case of the gear-case.

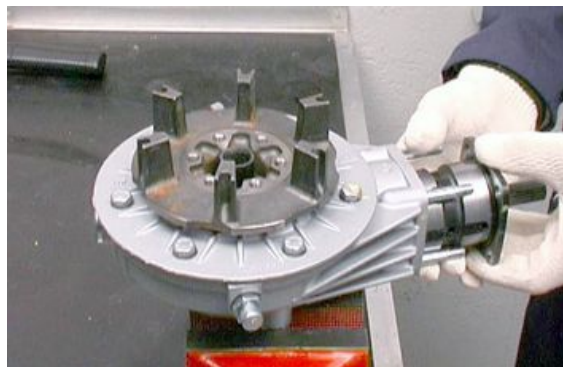

- Lock on the vice the sealing tool (19907100) of the bevel gear pair.



- Insert the grooved shank of the pinion on the tool and unscrew the nut.



- Slide off the spacer.
- Slide off the pinion.

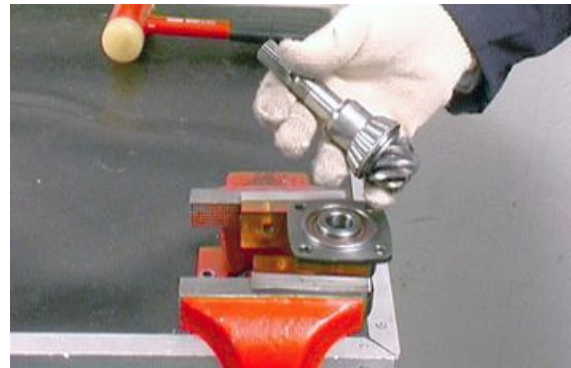

- Slide off the shim adjustment washer.
- Slide off the O-ring.

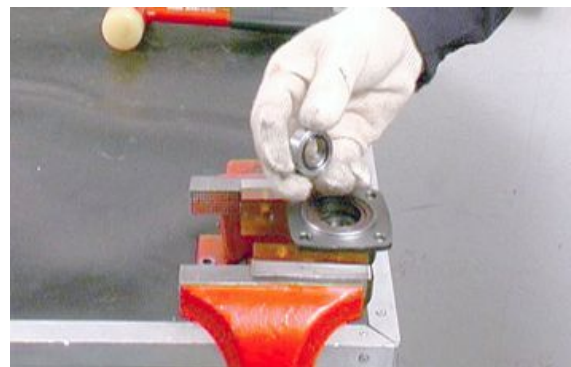

- Slide off the oil seal.

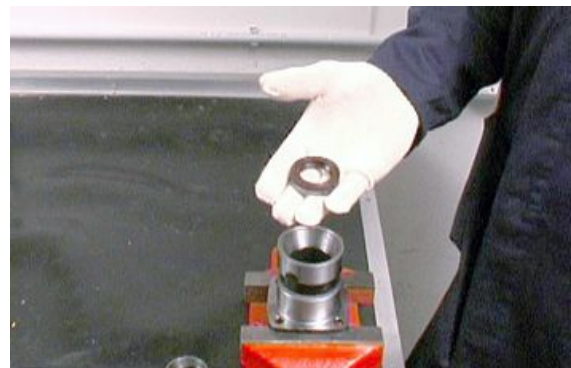

- Slide of the tapered bearing from the case.
- Slide off the O-ring.
- Slide off the spacer.
- Slide off the two shim washers.



- Slide off the tapered bearing from the case.

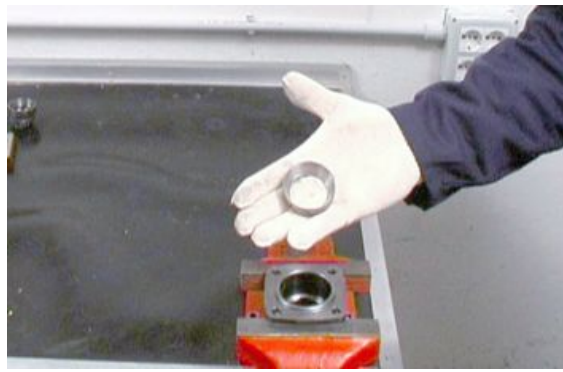

Controllo

- Check that the pinion tothing is not damaged, worn or deformed; otherwise, replace the pair.
- Check that both tapered bearings are not damaged, that the rollers are not damaged or worn; otherwise, replace them.
- Check that the adjustment washers are not deformed or broken; otherwise, replace them.
- Check that the sealing rings are not shattered, spoiled or worn; otherwise, replace them.

Montaggio

- If the bevel pinion should be replaced, replace also the crown fitted on the housing. The pinion and the crown should have the same number stamped.



- Fit the external ring of the tapered bearings on the bevel pinion holder case using the suitable punch (19926400).



- Fit the adjustment shim washer.



- Fit the internal ring of the bearing on the pinion using the suitable punch (19926200).



- Fit both shim washers on the pinion.
- Fit the spacer on the pinion.
- Fit the O-ring.



- Fit the complete pinion on the case using the suitable punch (19926100).



- Fit the oil seal.
- Fit the O-ring.



- Fit the spacer.



- Insert the grooved shank of the pinion on the tool (19907100) and tighten the nut.



Smontaggio gruppo scatola

- Undo the screws and collect the washers.



- Remove the braking disc from the drilled bolt.
- Undo the screws and collect the plates and the wave washers.
- Slide off the complete cover.
- Slide off the gaskets.
- Slide off the shimming ring.

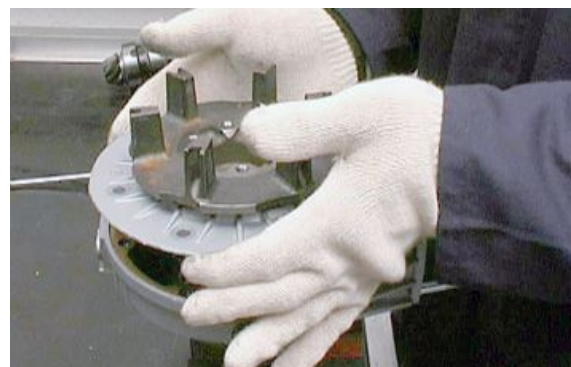

- Remove the O-ring from the groove on the drilled bolt.



From the cover, slide off:

- The needle bearing.
- Remove the internal ring of the needle bearing using a suitable punch (19907000).
- Remove the washer.
- Remove the washer.



- Undo the screws and collect the corresponding safety plates.

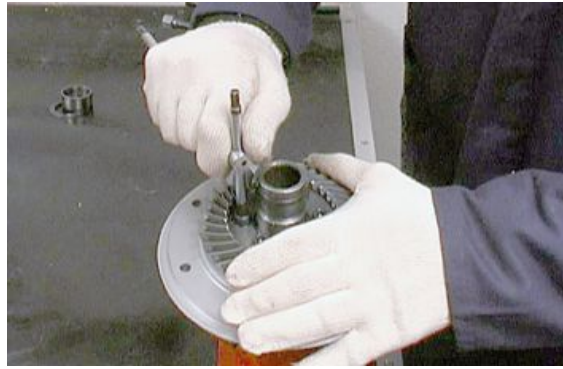

- Remove the conical crown.



- Slide off the drilled bolt from the bearing.



- Remove the sealing ring.



- Slide off the bearing from the cover using the suitable punch.

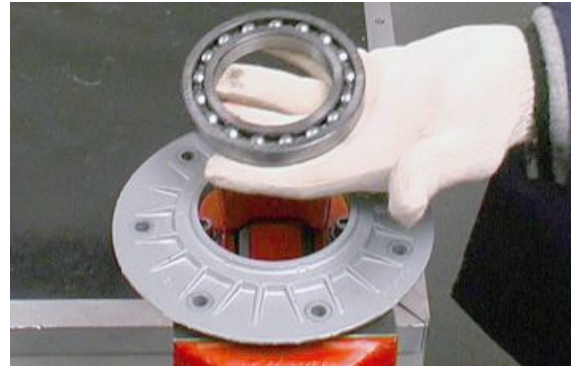

- Remove the external ring of the needle bearing from the housing using the suitable extractor (19927500).



- Remove the sealing ring and the washer.

**Controllo**

- Check that the drilled bolt tongues, where the anti-vibration rubbers operate, are not spoiled; that the surfaces of: the sealing ring; the bearing on the cover, the external ring of the bearing on the housing; the groove for the circlip on the drilled bolt are not worn, deformed or spoiled; otherwise, replace them.
- Check that the sealing ring on the housing is not shattered or is still flexible; otherwise, replace it.
- That the needle bearing on the housing does not have flattened or worn rollers; otherwise, replace it.
- Check efficiency of every component and that the coupling surfaces of the housing and cover are not scored or distorted.

Accoppiamento pignone corona

For coupling, proceed as follows:

- Provisionally lock the complete pinion case on the housing with two nuts and appropriate spacers.
- Fit the corresponding tool on the crown (19928800).



-
- Insert the tool on the bearing cage in the housing.



-
- Check alignment between pinion teeth and the crown teeth.
 - If alignment is not regular, properly vary the thickness of the ring between the pinion and the tapered bearing.
 - Also check the contact area between the pinion teeth and the crown teeth, proceeding as follows:



-
- Apply suitable colours available in the market on the pinion teeth.



- Fit the drilled bolt-crown unit cover and their spacers and gaskets on the housing and provisionally tighten the screws.



- On the crown holder drilled bolt, fit a "Universal" extractor that with appropriate central spacers slightly presses the crown towards the brake disc side.
- Turn the pinion in the riding direction, with the crown braked so that the rotation is carried out under load, and leaves a contact mark on the pinion surface.



- If the contact is regular, the mark on the pinion teeth will be like this (the pinion is seen from the crankshaft side)

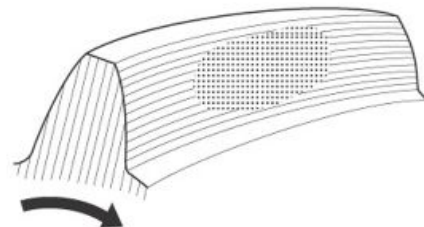

- If the contact is like this, the crown is too near the pinion rotation axis: detach the crown by increasing spacer thickness.

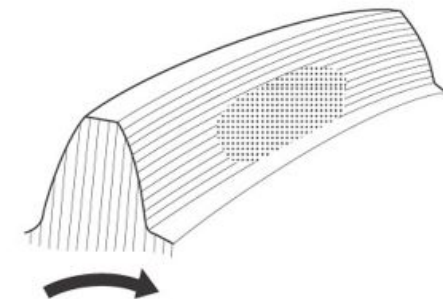

- If the contact is like this, the pinion is too near the rotation axis of the crown: detach the pinion by reducing spacer thickness

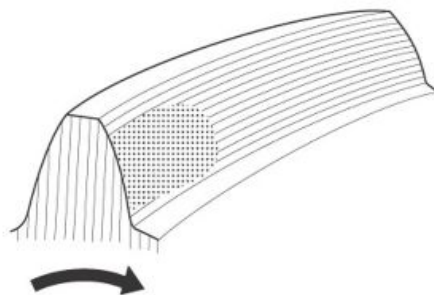

- If the contact is like this, the pinion is too far from the rotation axis of the crown: approach the pinion by increasing spacer thickness

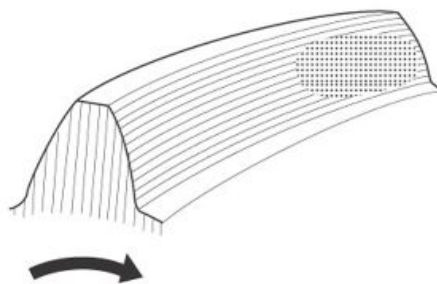

- If the contact is like this, the crown is too far from the pinion rotation axis: approach the crown by reducing spacer thickness.

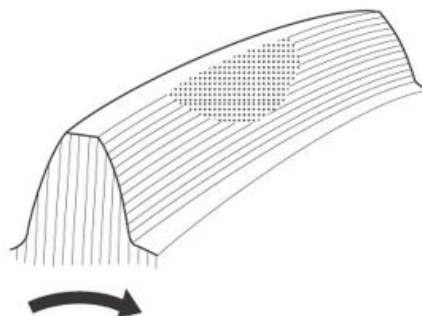

Montaggio gruppo scatola

- Fit the washer on the gearcase.

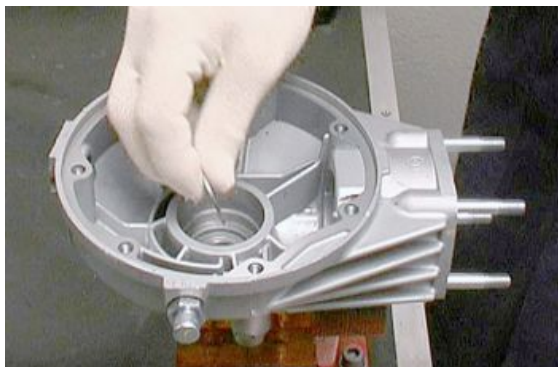

- Fit the sealing ring on the housing using the suitable punch (19926000).



- Fit the external ring of the needle bearing on the housing using the suitable punch (19926500).



- Fit the bearing on the cover using the suitable punch.

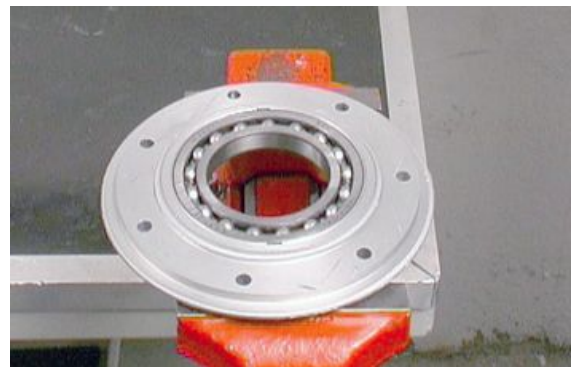

- Fit the internal ring of the needle bearing on the drilled bolt using the suitable punch (19927900).
- Insert the sealing ring in the drilled bolt.



- Fit the drilled bolt on the cover.

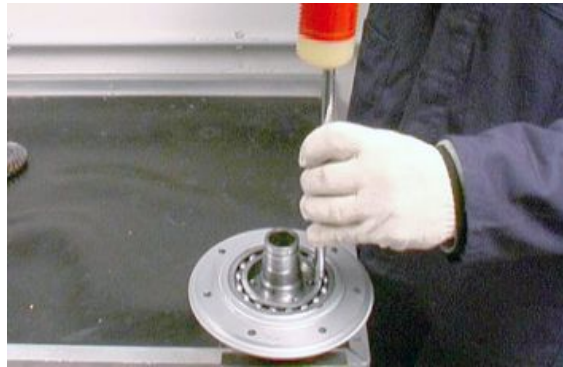

- Fit the crown.



- Fit the plates and tighten the screws.



- Insert the washer.



- Insert the washer.



- Fit the O-ring.
- Insert the gaskets and the shimming ring on the cover.
- Tighten the screws with plates and washers.



- Fit the braking disc on the drilled bolt by locking the screws with the washers using a torque wrench.





- When refitting the bevel pinion case on the transmission, bear in mind that the oil passage grooves with holes should be fitted vertically (observing the grooves, one should be facing upwards and the other facing the ground).



Installing

- Insert the sleeve and base on the bevel pinion of the gearcase.

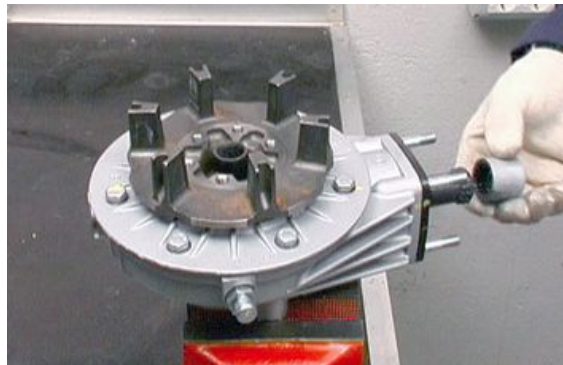
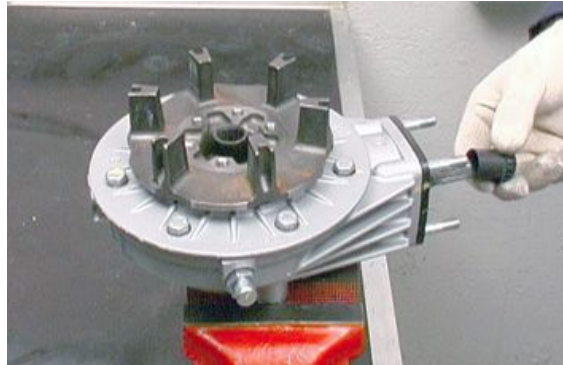

- Correctly insert the stud bolts of the gearcase in the holes of the swingarm .

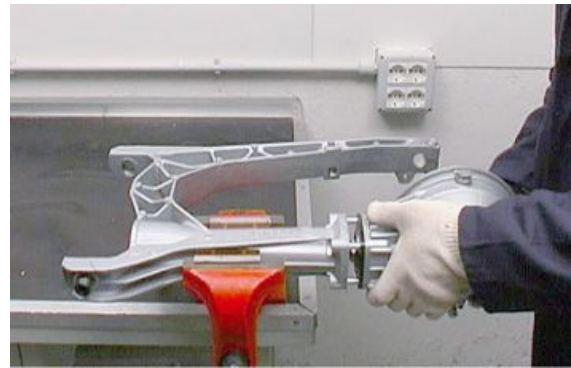

- Screw the nuts with the washers without locking them.

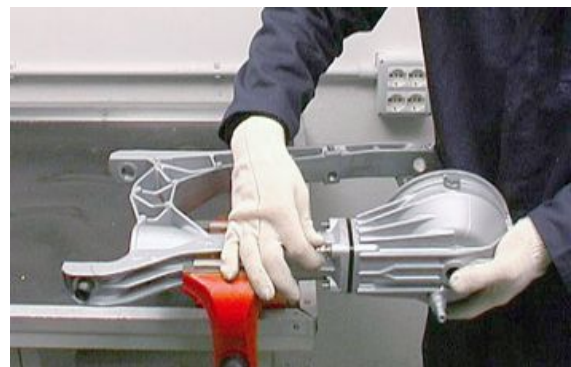

Exhaust

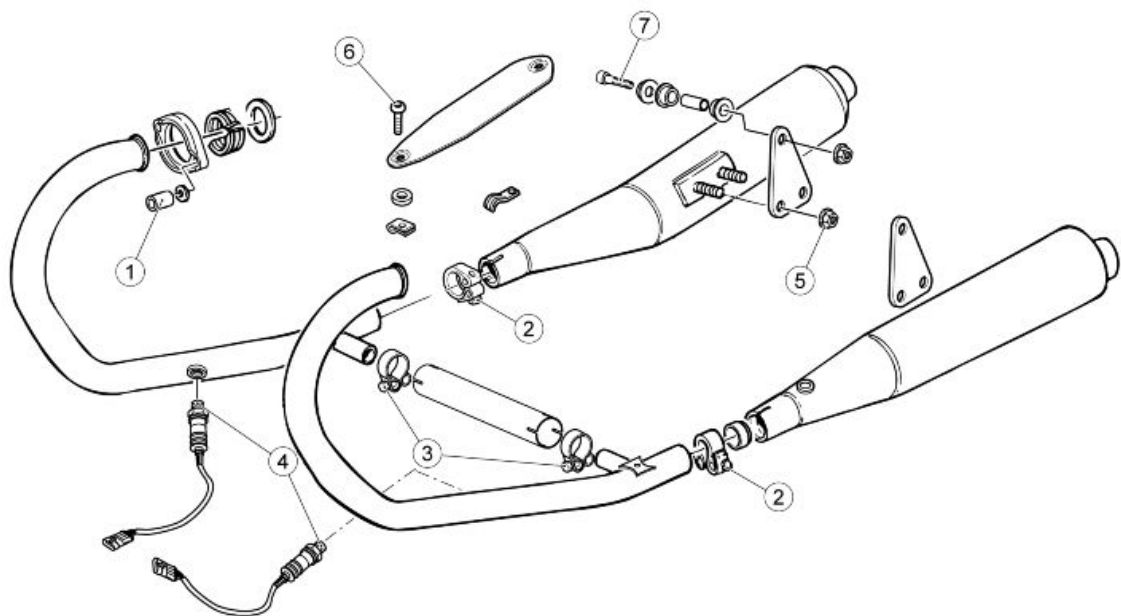

EXHAUST SYSTEM

Pos.	Description	Type	Quantity	Torque	Notes
1	Exhaust pipe fixing nut to the engine	M6	4	10 Nm (7.37 lb ft)	-

Pos.	Description	Type	Quantity	Torque	Notes
2	Exhaust pipe fixing clamp screw to the compensator	M6	1+1	10 Nm (7.37 lb ft)	-
3	Compensator fixing clamp screw to the silencer	M6	2	10 Nm (7.37 lb ft)	-
4	Lambda probe on compensator	M18x1.5	1	38 Nm (28.03 lb ft)	-
5	Nut fastening silencer to mounting plate	M8	4	25 Nm (18.44 lb ft)	-
6	Heat shield fixing screw	M6x12	6	10 Nm (7.37 lb ft)	Loctite 270
7	Screw fixing silencer mounting plate to frame	M8x40	2	25 Nm (18.44 lb ft)	-

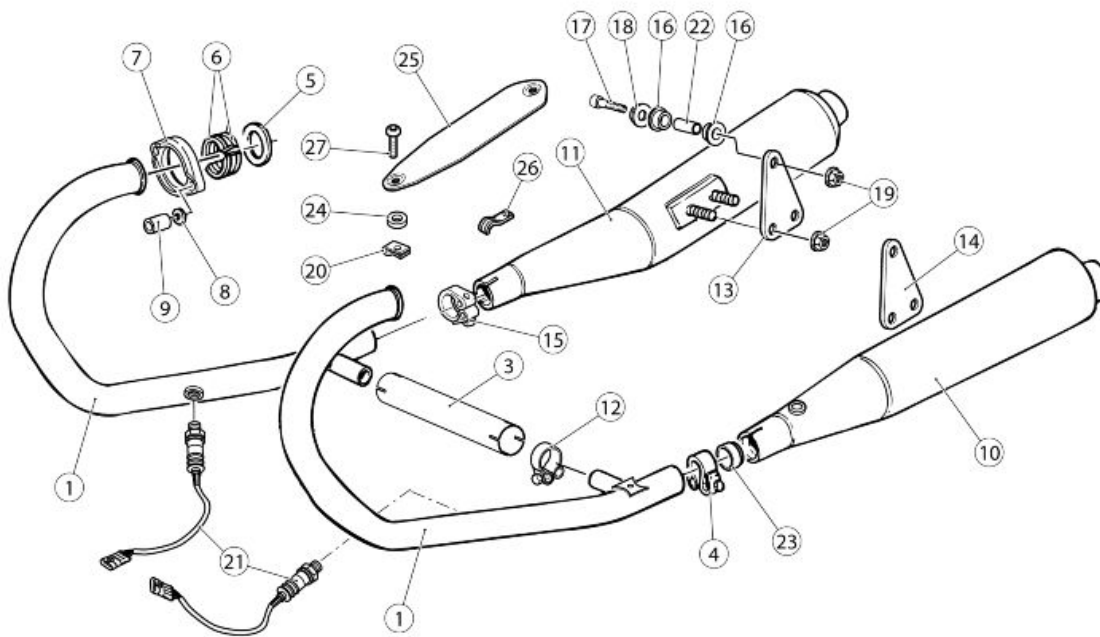
**key:**

1. Right exhaust pipe
2. Left exhaust pipe
3. Exhaust manifold fitting
4. Left silencer clamp
5. Gasket
6. Spacer
7. Ring nut
8. Washer
9. Nut
10. Left silencer
11. Right silencer
12. Clamp
13. Right plate
14. Left plate

- 15.Right silencer clamp
- 16.Muffler rubber ring
- 17.TCEI screw
- 18.Silencer fixing bushing
- 19.Nut
- 20.Elastic plate
- 21.Lambda probe
- 22.Spacer
- 23.Bushing
- 24.Insulating washer
- 25.Silencer heat protection
- 26.U-bolt
- 27.Flanged TBEI screw

Removing the tail pipe

The engine and the exhaust system components get very hot and remain in this condition for a certain time interval after the engine has been shut off. Before handling these components, make sure that you are wearing insulating gloves or wait until the engine and the exhaust system have cooled down.

- Loosens the clamps between the exhaust pipes and catalytic converter.



- Unscrew and remove the muffler fixing nut and collect the screw and the bushing.
- Remove the silencer

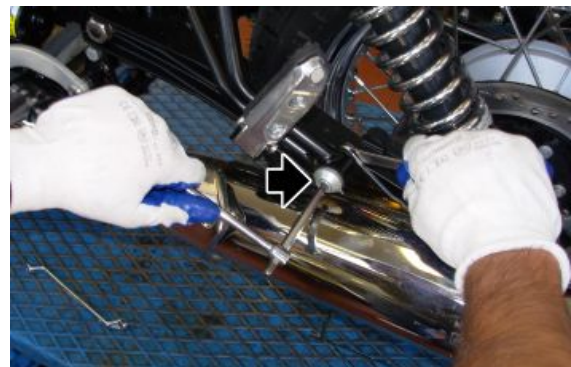

Removing the exhaust manifold

- Remove the exhaust ring fixing nuts, taking care to recover the washers

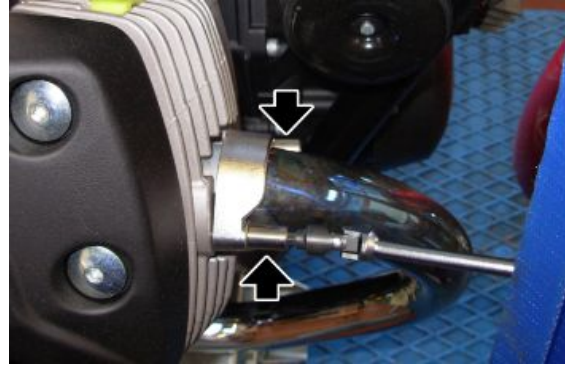

- Remove the spacers



- Remove the ring nuts

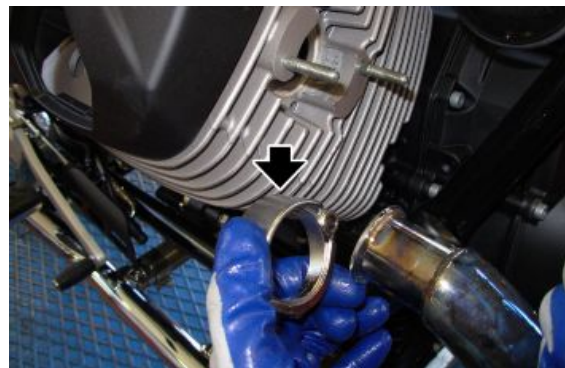

- Remove the starter motor in order to be able to disconnect the left lambda probe connector



- Disconnect the right Lambda probe connector and slide the cabling from the cable grommet



- Loosen the clamps between the joint and the exhaust manifolds
- Remove the manifolds



Removing the lambda sensor

- Disconnect the left lambda probe (1) and right lambda probe (2) connector.



- Unscrew and remove the lambda probes.



INDEX OF TOPICS

BODYWORK

BODYW

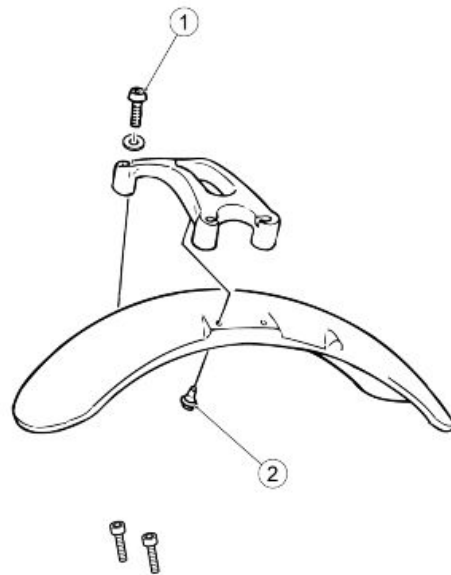
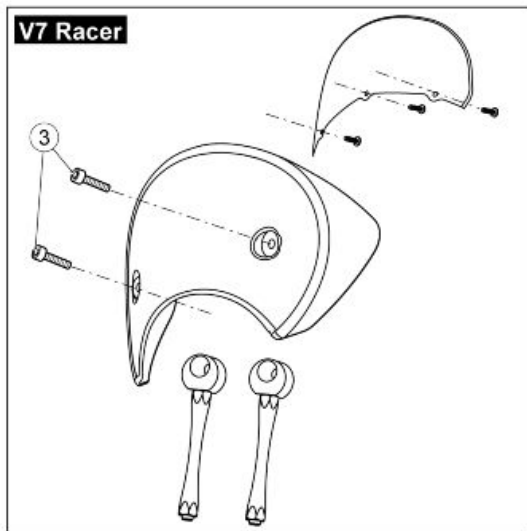

BODYWORK - FRONT SECTION

pos.	Description	Type	Quantity	Torque	Notes
1	Screw fastening stabiliser plate to fork	M8x40	4	15 Nm (11.06 lbf ft)	Loctite 243
2	Screw fastening mudguard to stabiliser plate	M6x11	4	10 Nm (7.37 lbf ft)	Loctite 243
3	Top fairing fixing screw	M6	2	10 Nm (7.37 lbf ft)	

(V7 RACER)

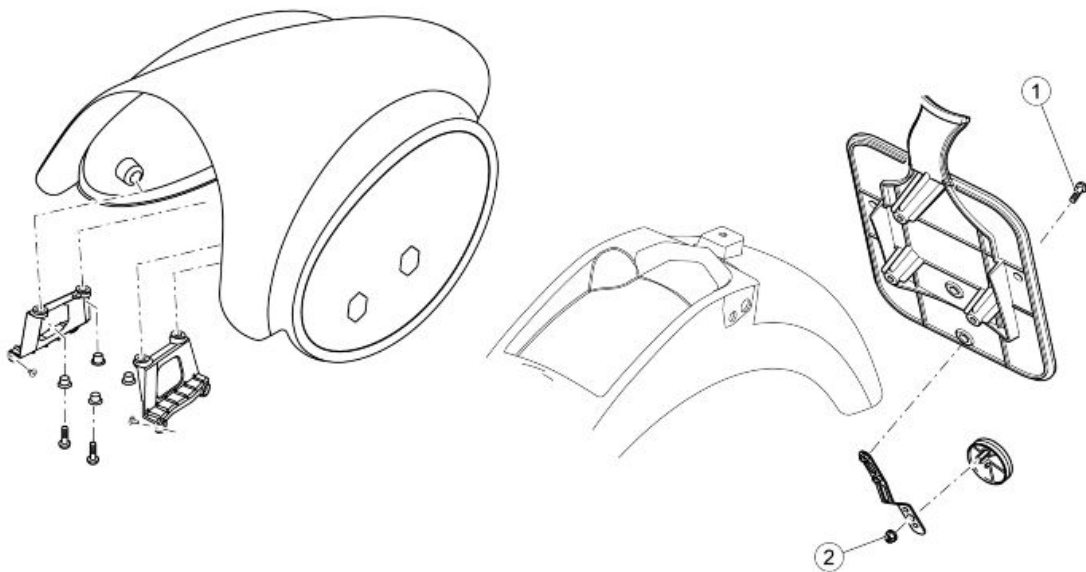

REAR SECTION BODYWORK - LICENSE PLATE MOUNTING

pos.	Description	Type	Quantity	Torque	Notes
1	Screw fastening retroreflector mounting to license plate mounting	M5x10	2	4 Nm (2.95 lbf ft)	-
2	Nut fixing retroreflector to mounting	M5	1	4 Nm (2.95 lbf ft)	-

Disassembling the lock

- Remove the left side fairing.
- Remove the fork spring



- Remove the cable support plate



- Extract the ignition switch assembly externally

**Side body panels**

(V7 SPECIAL / V7 STONE)

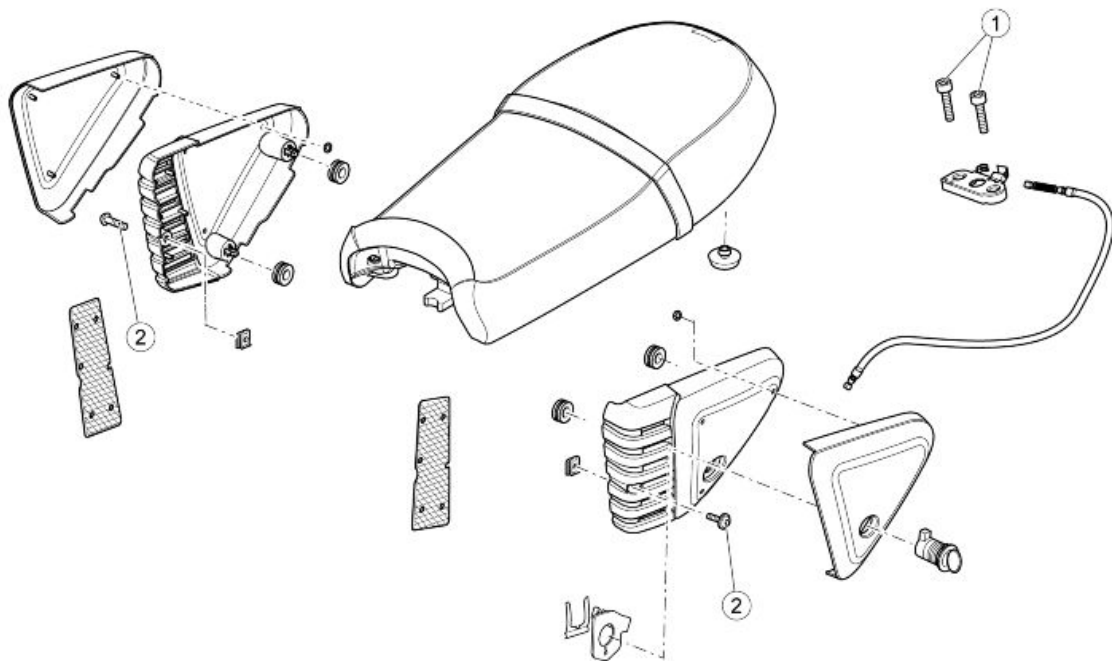

BODYWORK CENTRAL SECTION - SADDLE

pos.	Description	Type	Quantity	Torque	Notes
1	Saddle release block fixing screw	M6x25	2	10 Nm (2.37 lb ft)	-
2	Side fairing fixing screw	M5x9	2	4 Nm (2.95 lb ft)	-

(V7 RACER)

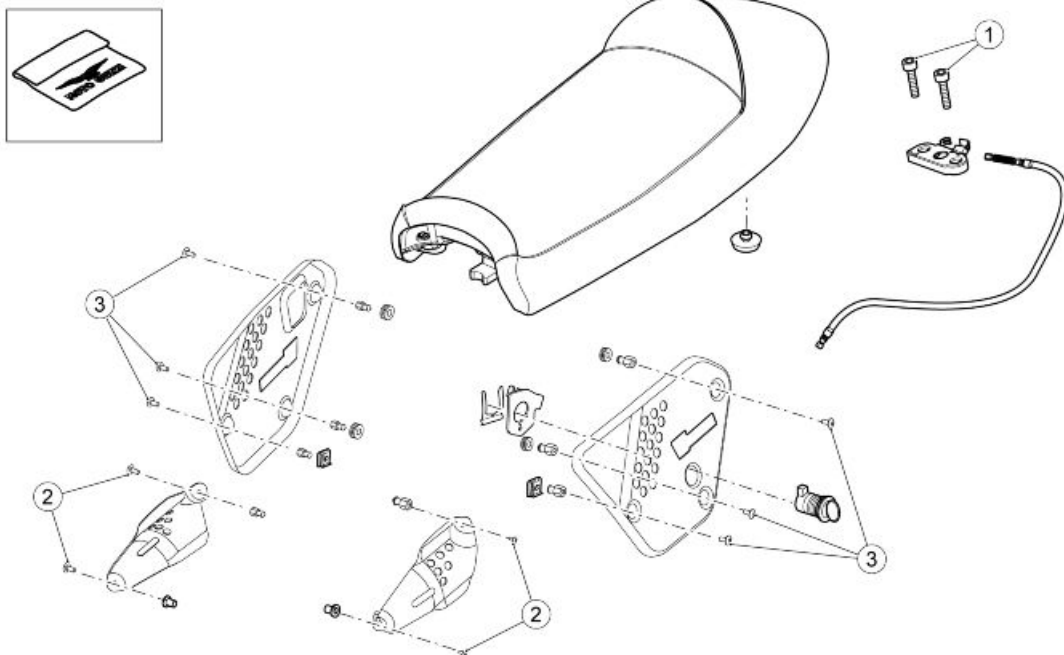

BODYWORK CENTRAL SECTION - SADDLE

pos.	Description	Type	Quantity	Torque	Notes
1	Saddle release block fixing screw	M6x25	2	10 Nm (2.37 lb ft)	-
2	Throttle body cover fastener screw	M5x14	4	4 Nm (2.95 lb ft)	-
3	Side fairing fixing screw	M5x9	6	4 Nm (2.95 lb ft)	-

(V7 SPECIAL / V7 STONE)

- Remove the side fairing fixing screw (1)
- Delicately unhook the pins (2) from the relative retaining rubber clamps
- Remove the side fairing.

**(V7 RACER)**

- Remove the side fairing fixing screw (1)
- Remove the side fairing.



- To remove the left side fairing the saddle opening cable (3) must be unhooked from the ignition switch assembly (4).



Rear mudguard

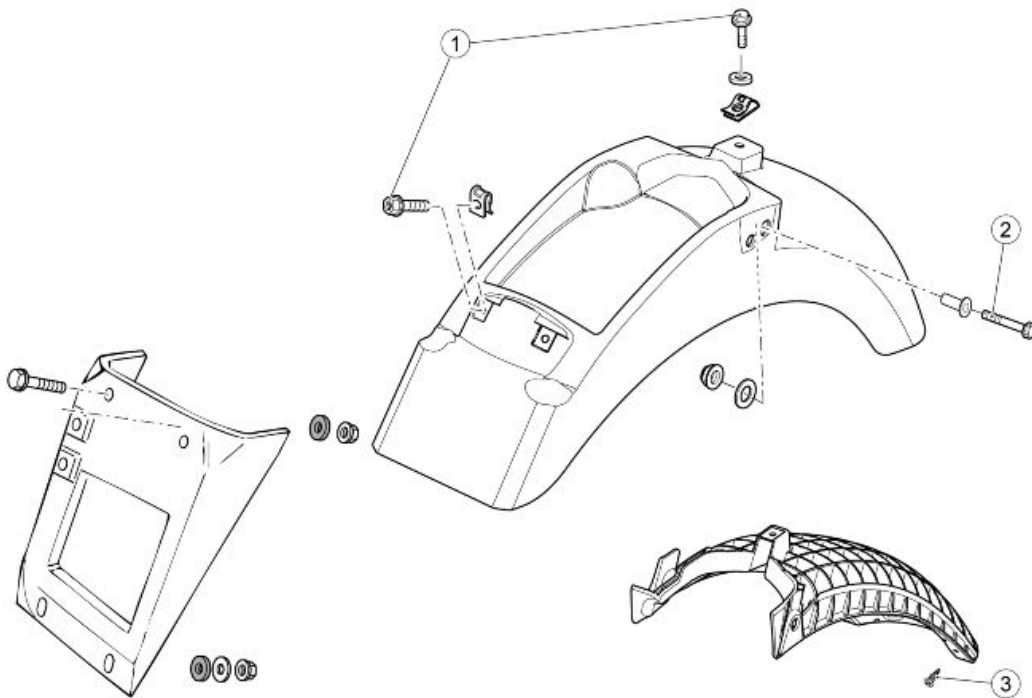

REAR MUDGUARD

pos.	Description	Type	Quantity	Torque	Notes
1	Rear mudguard front and central fixing screw	M6	2+1	10 Nm (7.37 lb ft)	
2	Rear mudguard side fixing screw	M8x30	2	25 Nm (18.44 lb ft)	
3	Screw fixing license plate holder to mudguard reinforcement	SWP M5x20	3	3 Nm (2.21 lb ft)	

- Remove the saddle
- Remove the upper central screw (1) that secures the mudguard to the frame



- After unhooking the opening cable from the ignition switch assembly, remove it from the mudguard.



- Remove the front screws (2) that secure the mudguard to the frame, taking care to recover the nuts

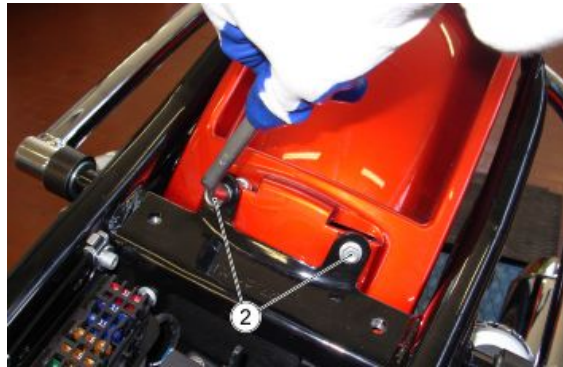

- Remove the lateral screws (3) that secure the mudguard and the passenger handgrips from both sides, taking care to recover the nuts



- Disconnect the taillight connector.



- Remove the rear mudguard by sliding the light cabling through the wheel housing



Splash guard

- Remove the lower screws (1)



- Remove the upper screws (2) taking care to recover the nuts



- Remove the splash guard, pulling it to the rear



Fuel tank

(V7 RACER)

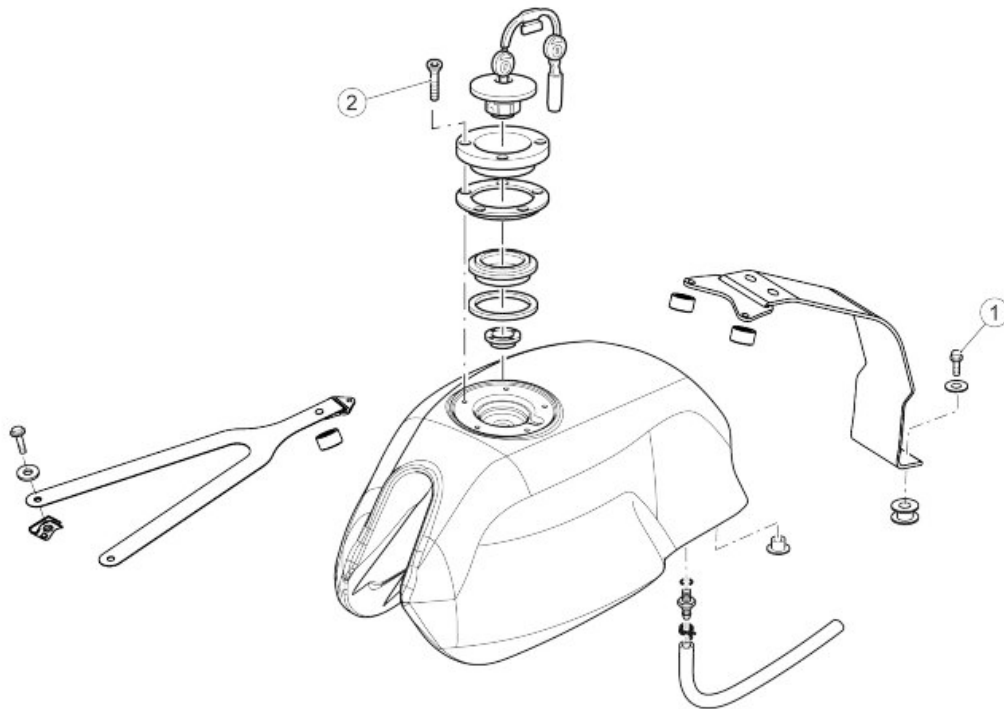

(V7 SPECIAL / V7 STONE)

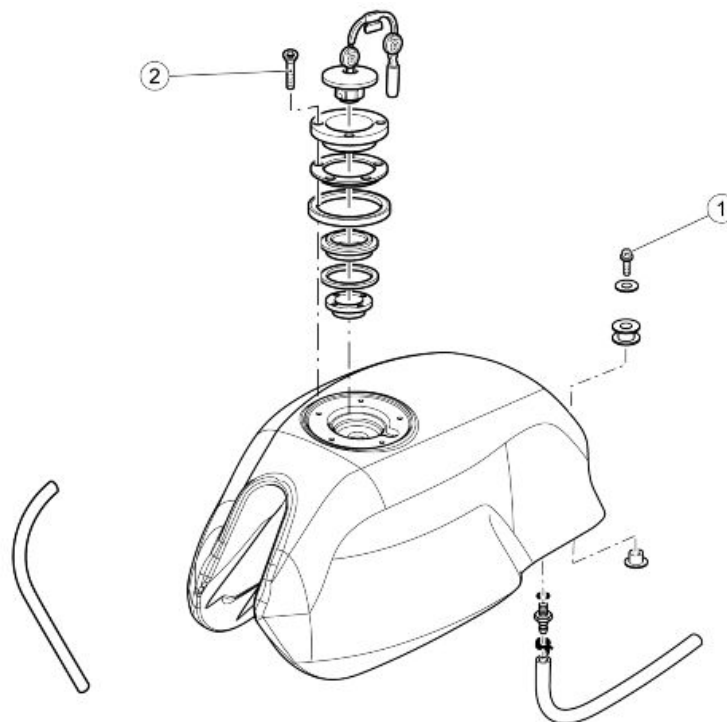

FUEL TANK

pos.	Description	Type	Quantity	Torque	Notes
1	Rear tank fixing screw	M8x45	1	25 Nm (18.44 lb ft)	-

pos.	Description	Type	Quantity	Torque	Notes
2	Screw fastening cap flange to tank	M5x12	2+3	4 Nm (2.95 lb ft)	-

(V7 SPECIAL / V7 STONE)

- Unscrew and remove the rear screw.



- Partially lift the fuel tank in order to be able to disconnect the fuel hose fitting, avoiding damaging it.

CAUTION

PAY PARTICULAR ATTENTION DURING THE LIFTING OPERATION IN THAT THE FUEL HOSE FITTING CAN BE DAMAGED



- Disconnect the connector.

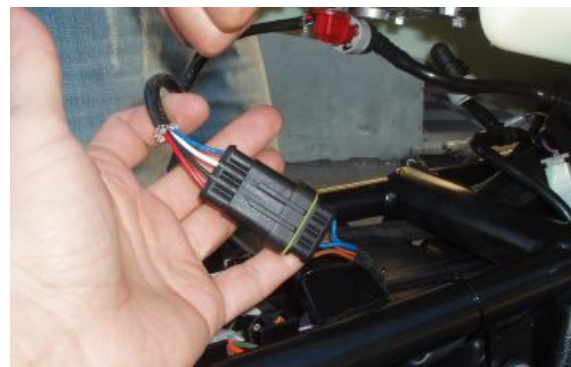

- Disconnect the fuel pipe.



- Remove the fuel breather pipe.



- Remove the fuel tank by sliding it off and back.

(V7 RACER)

- Remove the screws that fix the horns.



- Unscrew and remove the rear screw.



- Partially lift the fuel tank in order to be able to disconnect the fuel hose fitting, avoiding damaging it.

CAUTION

PAY PARTICULAR ATTENTION DURING THE LIFTING OPERATION IN THAT THE FUEL HOSE FITTING CAN BE DAMAGED



-
- Disconnect the connector.

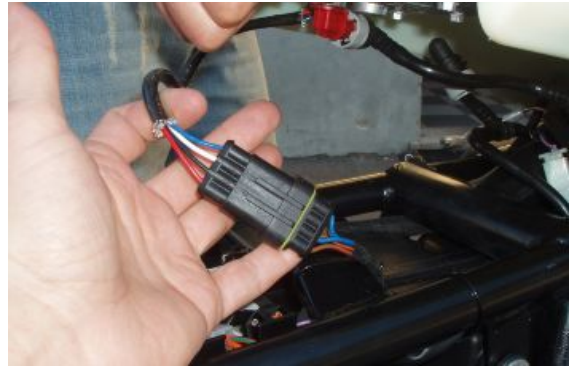

-
- Disconnect the fuel pipe.



-
- Remove the fuel breather pipe.



- Remove the fuel tank by sliding it off and back.
-

INDEX OF TOPICS

PRE-DELIVERY

PRE DE

Carry out the listed checks before delivering the motorcycle.

WARNING



HANDLE FUEL WITH CARE.

Aesthetic inspection

- Paintwork
- Fitting of Plastic Parts
- Scratches
- Dirt

Tightening torques inspection

- Safety fasteners:
 - front and rear suspension unit
 - front and rear brake calliper retainer unit
 - front and rear wheel unit
 - engine - chassis retainers
 - steering assembly
- Plastic parts fixing screws

Electrical system

- Main switch
- Headlamps: high beam lights, low beam lights, tail lights (front and rear) and their warning lights
- Headlight adjustment according to regulations in force
- Front and rear stop light switches and their bulbs
- Turn indicators and their warning lights
- Instrument panel lights
- Instrument panel: fuel and temperature indicator (if present)
- Instrument panel warning lights
- Horn
- Electric starter
- Engine stop via emergency stop switch and side stand
- Helmet compartment electrical opening switch (if present)

- Through the diagnosis tool, check that the last mapping version is present in the control unit/s and, if required, program the control unit/s again: consult the technical service website to know about available upgrades and details regarding the operation.

CAUTION

TO ENSURE MAXIMUM PERFORMANCE, THE BATTERY MUST BE CHARGED BEFORE USE. INADEQUATE CHARGING OF THE BATTERY WITH A LOW LEVEL OF ELECTROLYTE BEFORE IT IS FIRST USED SHORTENS BATTERY LIFE.

CAUTION

UPON INSTALLING THE BATTERY, ATTACH THE POSITIVE LEAD FIRST AND THEN THE NEGATIVE ONE, AND PERFORM THE REVERSE OPERATION UPON REMOVAL.

WARNING

THE BATTERY ELECTROLYTE IS POISONOUS AS IT MAY CAUSE SERIOUS BURNS. IT CONTAINS SULPHURIC ACID. AVOID CONTACT WITH YOUR EYES, SKIN AND CLOTHING. IN CASE OF CONTACT WITH YOUR EYES OR SKIN, WASH WITH ABUNDANT WATER FOR APPROX. 15 MIN. AND SEEK MEDICAL ATTENTION IMMEDIATELY. IF ACCIDENTALLY SWALLOWED, IMMEDIATELY DRINK LARGE QUANTITIES OF WATER OR VEGETABLE OIL. SEEK IMMEDIATE MEDICAL ATTENTION. BATTERIES PRODUCE EXPLOSIVE GASES; KEEP CLEAR OF NAKED FLAMES, SPARKS OR CIGARETTES. VENTILATE THE AREA WHEN RECHARGING INDOORS. ALWAYS WEAR EYE PROTECTION WHEN WORKING IN THE PROXIMITY OF BATTERIES. KEEP OUT OF THE REACH OF CHILDREN.

CAUTION

NEVER USE FUSES WITH A CAPACITY HIGHER THAN THE RECOMMENDED CAPACITY. USING A FUSE OF UNSUITABLE RATING MAY SERIOUSLY DAMAGE THE VEHICLE OR EVEN CAUSE A FIRE.

Levels check

- Hydraulic braking system fluid level
- Clutch system fluid level (if present)
- Gearbox oil level (if present)
- Transmission oil level (if present)
- Engine coolant level (if present)
- Engine oil level
- Mixer oil level (if present)

Road test

- Cold start
- Instrument panel operation

-
- Response to throttle control
 - Stability when accelerating and braking
 - Front and rear brake efficiency
 - Front and rear suspension efficiency
 - Abnormal noise
-

Static test

Static check after test drive:

- Restarting when warmed up
 - Starter operation (if present)
 - Minimum holding (turning the handlebar)
 - Uniform turning of the steering
 - Possible leaks
 - Radiator electric fan operation (if present)
-

Functional inspection

- Hydraulic braking system
- Stroke of brake and clutch levers (if present)
- Clutch - Check for correct operation
- Engine - Check for correct general operation and absence of abnormal noise
- Other
- Documentation check:
 - Chassis and engine numbers check
 - Supplied tools check
 - License plate fitting
 - Locks checking
 - Tyre pressure check
 - Installation of mirrors and any possible accessories



NEVER EXCEED THE RECOMMENDED INFLATION PRESSURES AS TYRES MAY BURST.
CAUTION



CHECK AND ADJUST TYRE PRESSURE WITH TYRES AT AMBIENT TEMPERATURE.

Specific operations for the vehicle

(V7 RACER)

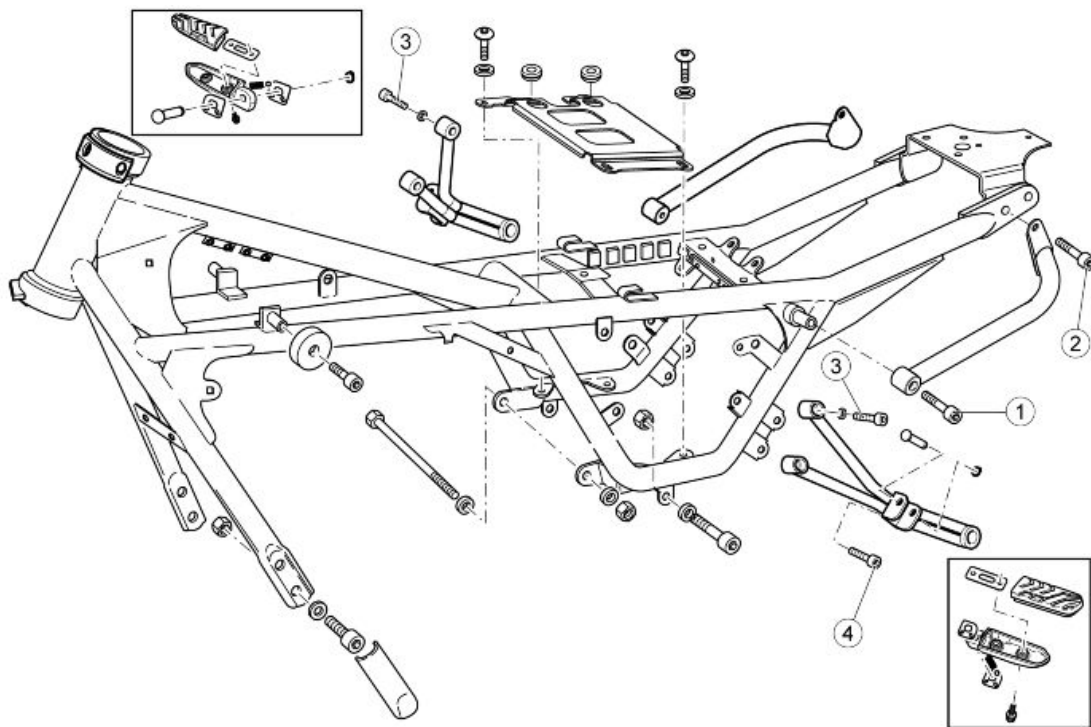
**TWO SEATER VERSION**

pos.	Description	Type	Quantity	Torque	Notes
1	Passenger handgrip front fixing screw	M6	2	10 Nm (7.37 lbf ft)	-
2	Passenger handgrip rear fixing nut	M8	2	25 Nm (18.44 lbf ft)	-
3	Passenger footrest mounting bracket fixing screw	M8x16	4	25 Nm (18.44 lbf ft)	Loctite 243
4	Countersunk-head Allen screw	M8	2	25 Nm (18.44 lbf ft)	-

WARNING**OPERATIONS REQUIRED TO RENDER VEHICLE COMPLIANT WITH TWO SEATER TYPE APPROVAL.**

- Remove the three fixing screws of the exhaust mounting plate.
- Remove the mounting plate.



- Fit the exhaust mounting plate preset for fixing the passenger footrest, so as to turn the vehicle into a two seater version.
- Tighten the three fastener screws to the specified torque.



- Fit the countersunk screw with hexagonal hole on "C" supporting the pedal and afterwards fit the washer.



- Place "C" on the exhaust supporting plate, pay attention that the holes to insert the pedal are adequately oriented.
- Hold the countersunk screw with hexagonal hole firmly in place and tighten the nut to 25 Nm (18.44 lbf ft).



- Position the pedal on "C" and insert the fixing pin.

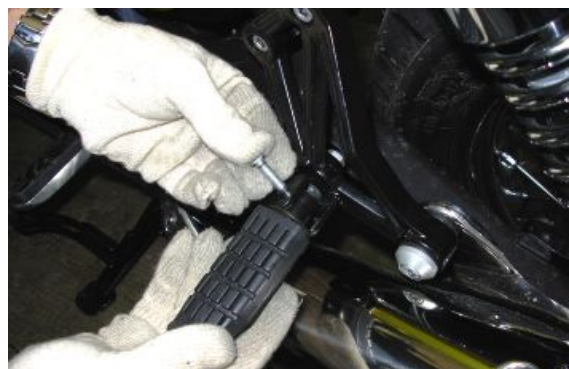

- Lock the bolt with the Seeger ring.

**NOTE**

REPEAT THE STEPS TO FIT THE PASSENGER FOOTPEG ON THE OPPOSITE SIDE.

Rotazione ammortizzatori e posizionamento maniglie passeggero

- Remove the two shock absorber fixing screws.



- Turn the shock absorber as shown and fasten it at the bottom.
- Fit the passenger handgrip and tighten the screw to the prescribed torque.



- Tighten the passenger handgrip rear fastening screw.

**NOTE**

REPEAT THE PROCEDURE TO MODIFY EVEN THE OTHER SIDE.

SADDLE

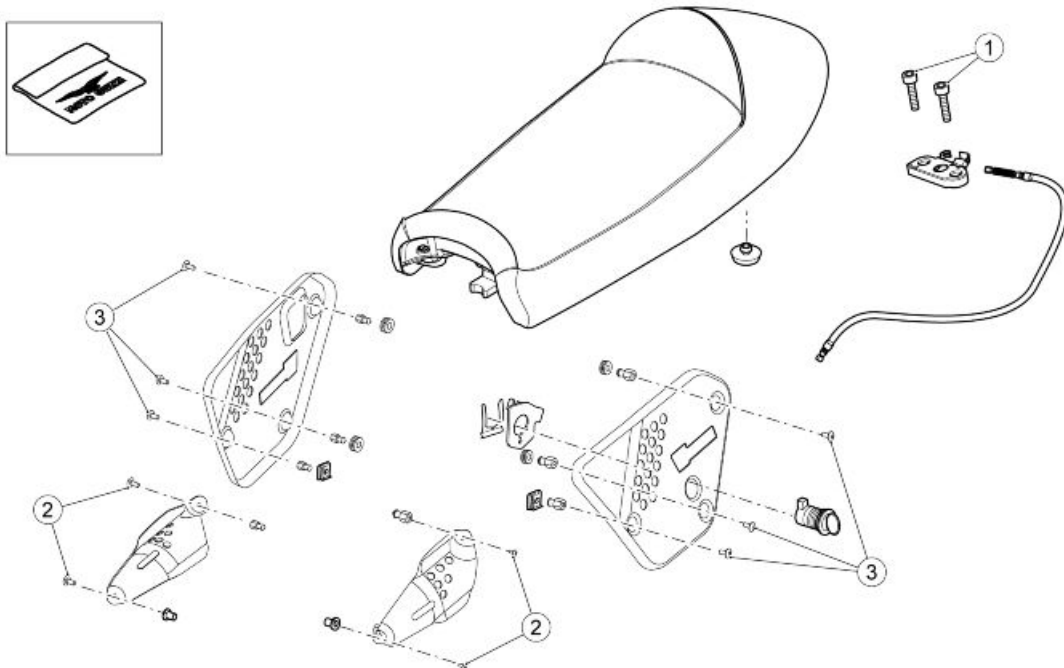

BODYWORK CENTRAL SECTION - SADDLE

pos.	Description	Type	Quantity	Torque	Notes
1	Saddle release block fixing screw	M6x25	2	10 Nm (2.37 lb ft)	-
2	Throttle body cover fastener screw	M5x14	4	4 Nm (2.95 lb ft)	-
3	Side fairing fixing screw	M5x9	6	4 Nm (2.95 lb ft)	-

Sostituzione sella

- Insert the key in the lock and turn it clockwise.
- Remove the single-seat saddle.



- Place the two-seat saddle.



A

Air filter: *45, 50, 51, 54*

Air temperature sensor: *103*

B

Battery: *79, 83*

Brake:

Brake lever:

Bulbs:

C

Clutch: *101*

Coil: *96*

Connectors: *106*

E

ECU: *106, 125*

Electrical system: *12, 60, 62, 189*

Engine oil: *43*

Engine temperature sensor: *86*

Exhaust: *171, 174*

Exhaust manifold: *174*

F

Filter box:

Fork: *130, 132, 136, 137, 141*

Front wheel: *127*

Fuel: *95, 109, 184*

Fuel pump: *95*

Fuses: *83*

H

Handlebar: *127*

I

Identification: *10*

Instrument panel: *103*

M

Maintenance: *8, 41*

Maintenance Table:

Mudguard: *181*

O

Oil filter: *45*

Oil pressure sensor: *99*

R

Rear wheel:

Recommended products: 36

Run/Stop switch: 105

S

Saddle:

Shock absorbers: 145

Side stand: 102

Side stand sensor: 102

Spark plugs:

Speed sensor: 84

Stand: 102

Start-up: 80

T

Tank: 109, 184

Throttle body: 46, 48

Transmission: 12, 42

Tyres: 14

W

Warning lights:

Wiring diagram: 76