



MOTO GUZZI®

PROUDLY AUTHENTIC MOTORCYCLES. SINCE 1921.

MANUALE STAZIONE DI SERVIZIO

2Q000468

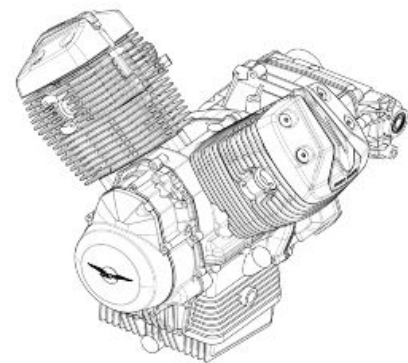

Engine 850 E5 V7-V9



MANUALE STAZIONE DI SERVIZIO

Engine 850 E5 V7-V9

THE VALUE OF SERVICE

As a result of continuous updates and specific technical training programmes for Moto Guzzi products, only **Moto Guzzi** Official Network mechanics know this vehicle fully and have the specific tools necessary to carry out maintenance and repair operations correctly.

The reliability of the vehicle also depends on its mechanical conditions. Checking the vehicle before riding it, its regular maintenance and the use of **original Moto Guzzi spare parts** only are essential factors!

For information on the nearest **Official Dealer and/or Service Centre** consult our website:

www.motoguzzi.com

Only by requesting Moto Guzzi original spare parts can you be sure of purchasing products that were developed and tested during the actual vehicle design stage. All Moto Guzzi original spare parts undergo quality control procedures to guarantee reliability and durability.

The descriptions and images in this publication are given for illustrative purposes only and are not binding. While the basic characteristics as described and illustrated in this booklet remain unchanged, Piaggio & C. S.p.A. reserves the right, at any time and without being required to update this publication beforehand, to make any changes to components, parts or accessories, which it considers necessary to improve the product or which are required for manufacturing or construction reasons.

Not all versions/models shown in this publication are available in all countries. The availability of individual versions should be checked with the Official Moto Guzzi sales network.

The Moto Guzzi brand is owned by Piaggio & C. S.p.A.

© Copyright 2021 - Piaggio & C. S.p.A. All rights reserved. Reproduction of this publication in whole or in part is prohibited.

Piaggio & C. S.p.A. Viale Rinaldo Piaggio, 25 - 56025 PONTEDERA (PI), Italy

www.piaggio.com

MANUALE STAZIONE DI SERVIZIO

Engine 850 E5 V7-V9

Questo manuale fornisce le informazioni principali per le procedure di normale intervento sul veicolo. Questa pubblicazione è indirizzata ai **Concessionari Moto Guzzi** e ai loro meccanici qualificati; molte nozioni sono state volutamente omesse, perché giudicate superflue. Non essendo possibile includere nozioni meccaniche complete in questa pubblicazione, le persone che utilizzano questo manuale devono essere in possesso sia di una preparazione meccanica di base, che di una conoscenza minima sulle procedure inerenti ai sistemi di riparazione dei motoveicoli. Senza queste conoscenze, la riparazione o il controllo del veicolo potrebbe essere inefficiente o pericolosa. Non essendo descritte dettagliatamente tutte le procedure per la riparazione, e il controllo del veicolo, bisogna adottare particolare attenzione al fine di evitare danni ai componenti e alle persone. Per offrire al cliente maggiore soddisfazione dall'uso del veicolo, **Moto Guzzi** s.p.a. si impegna a migliorare continuamente i propri prodotti e la relativa documentazione. Le principali modifiche tecniche e modifiche alle procedure per le riparazioni del veicolo vengono comunicate a tutti i **Punti Vendita Moto Guzzi e alle Filiali nel Mondo**. Tali modifiche verranno apportate, nelle edizioni successive di questo manuale. Nel caso di necessità o dubbi sulle procedure di riparazione e di controllo, interpellare il **REPARTO ASSISTENZA Moto Guzzi**, il quale sarà in grado di fornirvi qualsiasi informazione al riguardo, oltre a fornire eventuali comunicazioni su aggiornamenti e modifiche tecniche applicate al veicolo.

NOTE Provides key information to make the procedure easier to understand and carry out.

CAUTION Refers to specific procedures to carry out for preventing damages to the vehicle.

WARNING Refers to specific procedures to carry out to prevent injuries to the repairer.



Personal safety Failure to completely observe these instructions will result in serious risk of personal injury.



Safeguarding the environment Sections marked with this symbol indicate the correct use of the vehicle to prevent damaging the environment.



Vehicle intactness The incomplete or non-observance of these regulations leads to the risk of serious damage to the vehicle and sometimes even the invalidity of the guarantee

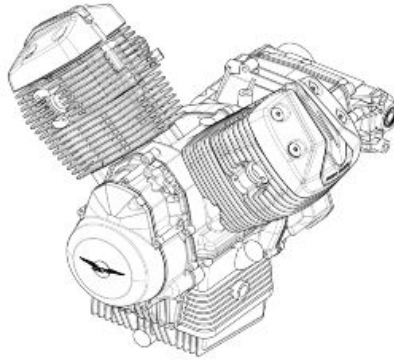

INDEX OF TOPICS

CHARACTERISTICS

CHAR

SPECIAL TOOLS

S-TOOLS

ENGINE

ENG

INDEX OF TOPICS

CHARACTERISTICS

CHAR

Tightening Torques

If the following tables do not expressly indicate the tightening torque values, refer to the table with the generic torque values indicated below.

GENERAL TIGHTENING TORQUES

	M4	M5	M6	M8	M10	M12
Metric tightening torque: TE - TEFL - SHC - TBEI - TCC - TS	3 Nm (2.21 lbf ft)	6 Nm (4.43 lbf ft)	10 Nm (7.38 lbf ft)	25 Nm (18.44 lbf ft)	50 Nm (36.88 lbf ft)	80 Nm (59.00 lbf ft)

GENERAL TIGHTENING TORQUES FOR SELF TAPPING SCREWS FOR PLASTIC

	2.9 mm	3.9 mm	4.2 mm	5 mm
Tightening torque	2 Nm (1.48 lbf ft)	2 Nm (1.48 lbf ft)	3 Nm (2.21 lbf ft)	3 Nm (2.21 lbf ft)

CAUTION

THE SCREWS WITH THREAD-LOCK SEALANT (PRE-IMPREGNATED) MUST BE REPLACED WITH NEW SCREWS AFTER THEY HAVE BEEN LOOSENED. BEFORE FITTING THE NEW SCREWS, CLEAN THE THREADED HOLES CAREFULLY, MAKING SURE THAT ALL TRACES OF THE OLD THREAD-LOCK SEALANT HAVE BEEN ELIMINATED.

Engine

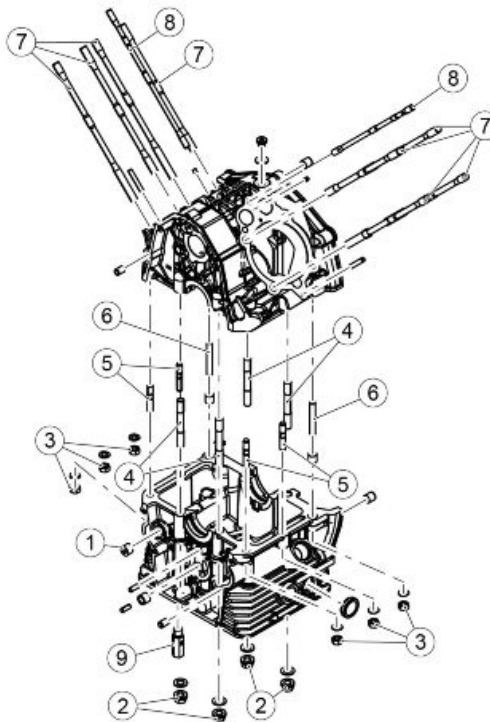

CRANKCASE

Pos.	Description	Type	Quantity	Torque	Note
1	Cap	M14	1	15-19 Nm (11.06-14.01 lb ft)	Pre-applied Loct.-LOCTITE DRI-SEAL 506 alternatively LOCTITE 5061 - Regularly check that the cap is levelled

Pos.	Description	Type	Quantity	Torque	Note
2	Crankcase half flanged nuts (pre-tightening)	M10	4	22-27 Nm (16.23-19.91 lb ft)	-
2	Crankcase half flanged nuts (final tightening)	M10	4	44-49 Nm (32.45-36.14 lb ft)	-
3	Crankcase half nuts	M8	6	22-25 Nm (16.23-18.44 lb ft)	-
4	Crankcase half stud bolts	M10	4	22-25 Nm (16.23-18.44 lb ft)	Pre-applied Loct. - LOCTITE DRI-LOC 211 alternative 3MSCOTCH GRIP 2510
5	Crankcase half stud bolts	M8	4	22-25 Nm (16.23-18.44 lb ft)	-
6	Crankcase half stud bolts	M8	2	22-25 Nm (16.23-18.44 lb ft)	-
7	Long/short head stud bolts	M10	8	9-11 Nm (6.64-8.11 lb ft)	Pre-applied Loct.; alternatively Loct. DRI-LOC 211 / 3M SCOTCH GRIP 2510
8	Central head stud bolts	M8	2	9-11 Nm (6.64-8.11 lb ft)	Pre-applied Loct.; alternatively Loct. DRI-LOC 211 / 3M SCOTCH GRIP 2510
9	Oil filter joint	M12	1	20-24 Nm (14.75-17.70 lb ft)	-

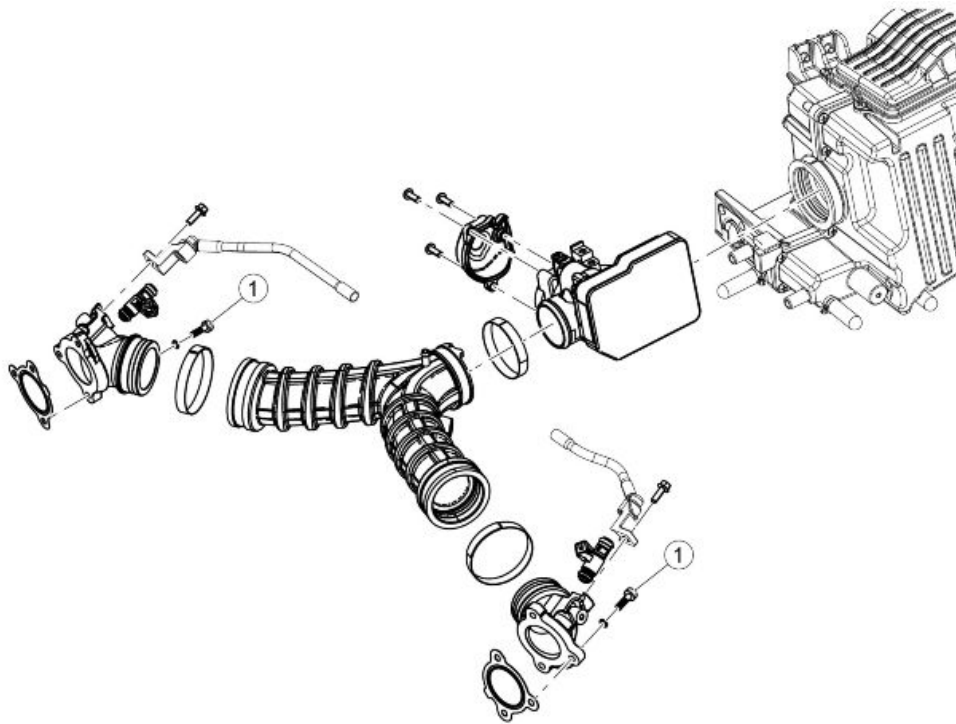

THROTTLE BODY

Pos.	Description	Type	Quantity	Torque	Note
1	Intake fittings screws	M6x22	6	9-11 Nm (6.64-8.11 lb ft)	-

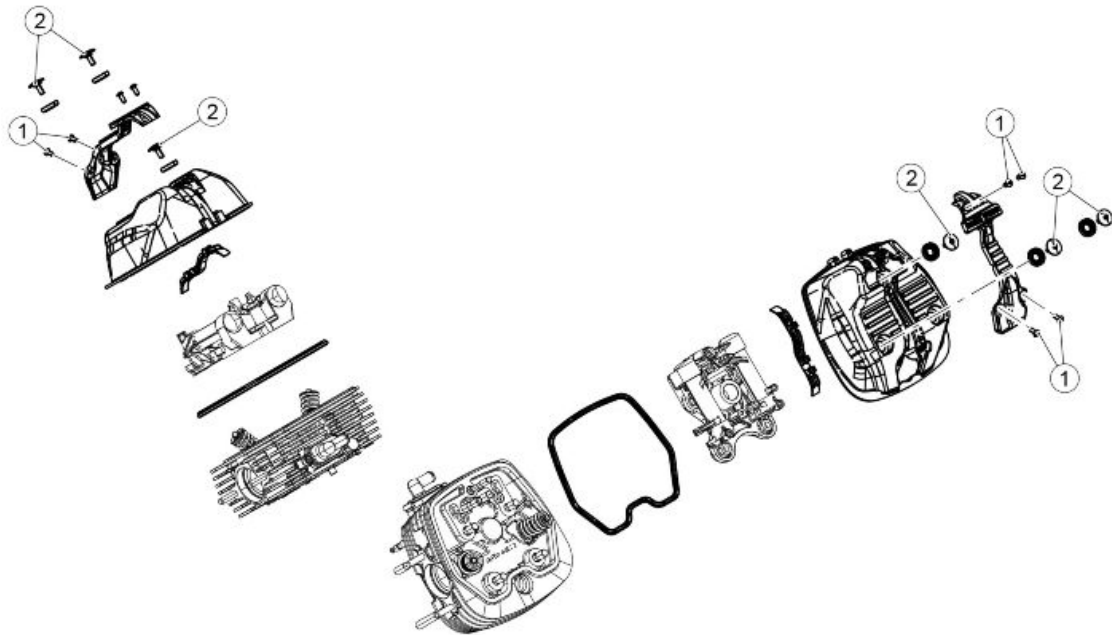

HEADS COVERS

Pos.	Description	Type	Quantity	Torque	Note
1	Spark plugs cover hex socket screws	M5x12	8	6-8 Nm (4.42-5.90 lb ft)	-
2	Head covers screws	M6	6	9-11 Nm (6.64-8.11 lb ft)	-
-	Spark plugs	-	2	10-12 Nm (7.38-8.85 lb ft)	-
-	Rounded head torx screws for spark plugs cable clamp on head covers	M4	4	2.6-3.1 Nm (1.92-2.29 lb ft)	-

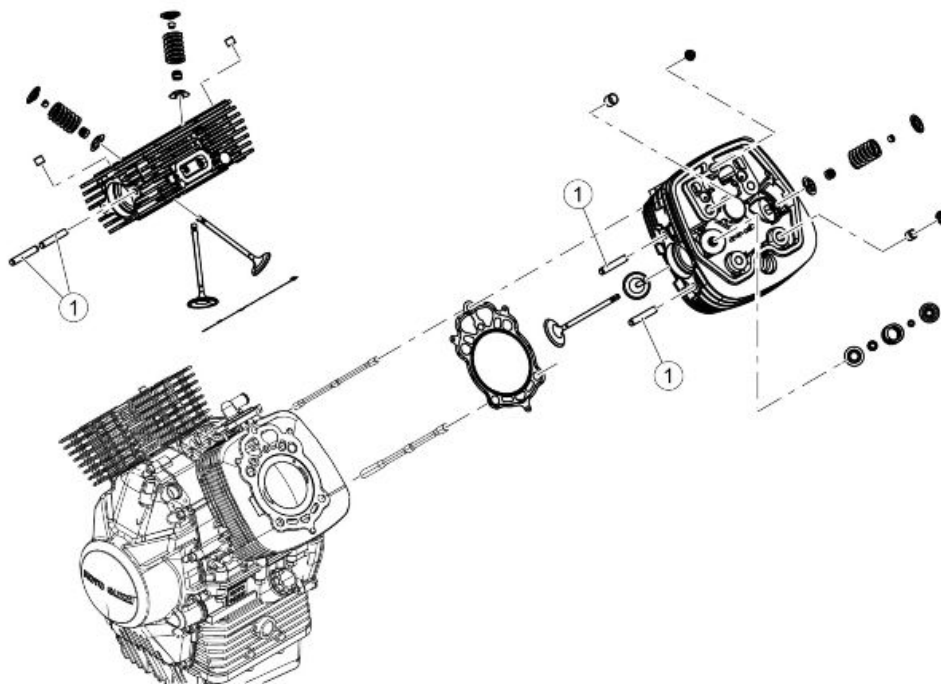

HEAD - VALVES

Pos.	Description	Type	Quantity	Torque	Note
1	Stud bolts for exhaust manifolds	M8	4	20-24 Nm (14.75-17.70 lb ft)	-

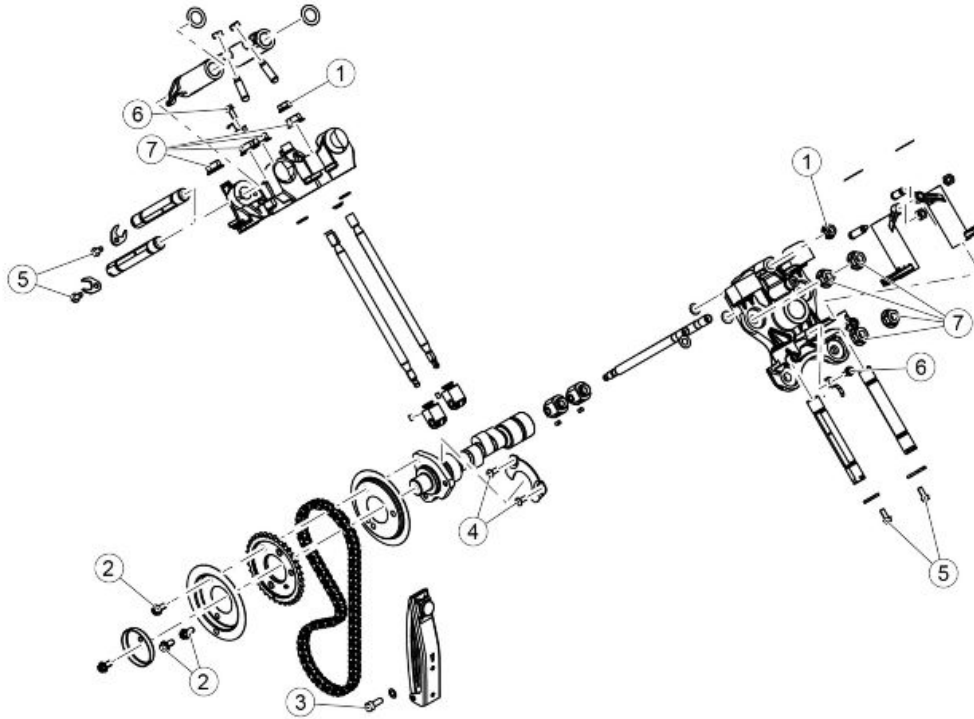

TIMING SYSTEM

Pos.	Description	Type	Quantity	Torque	Note
1	Stud bolt fixing nut (pre-tightening)	M8	2	9-11.5 Nm (6.64-8.48 lb ft)	Lubricate the threads and the support surface with MOLYCOTE GRAPID PLUS SPRAY grease
1	Stud bolt fixing nut (final tightening)	M8	2	90° +/- 5% - 14-19 Nm (10.32-14.01 lbf ft)	Lubricate the threads and the support surface with MOLYCOTE GRAPID PLUS SPRAY grease
2	Timing system sprocket flanged hex head screws	M6	3	9-11 Nm (6.64-8.11 lb ft)	Pre-applied Loct.; alternatively 3M SCOTCH-GRIP 2353
3	Chain tensioner screw	M6	1	9-11 Nm (6.64-8.11 lb ft)	-
4	Camshaft retainer plate torx rounded head screws	M5x12	2	6-7 Nm (4.42-5.16 lb ft)	Pre-applied Loct.; alternatively 3M SCOTCH-GRIP 2353
5	Rocker axles forks hex head flanged screws	M5x12	4	7-8 Nm (5.16-5.90 lb ft)	-
6	Flanged HH screws for ground plates on rocker supports	M5x12	2	7-8 Nm (5.16-5.90 lb ft)	-
7	Stud bolt fixing nuts (pre-tightening)	M10	8	13-16.6 Nm (9.59-12.24 lb ft)	Lubricate the threads and the support surface with MOLYCOTE

Pos.	Description	Type	Quantity	Torque	Note
7	Stud bolt fixing nuts (final tightening)	M10	8	90° +/- 5% - 24-34 Nm (17.70-25.01 lbf ft)	GRAPID PLUS SPRAY grease Lubricate the threads and the support surface with MOLYCOTE GRAPID PLUS SPRAY grease

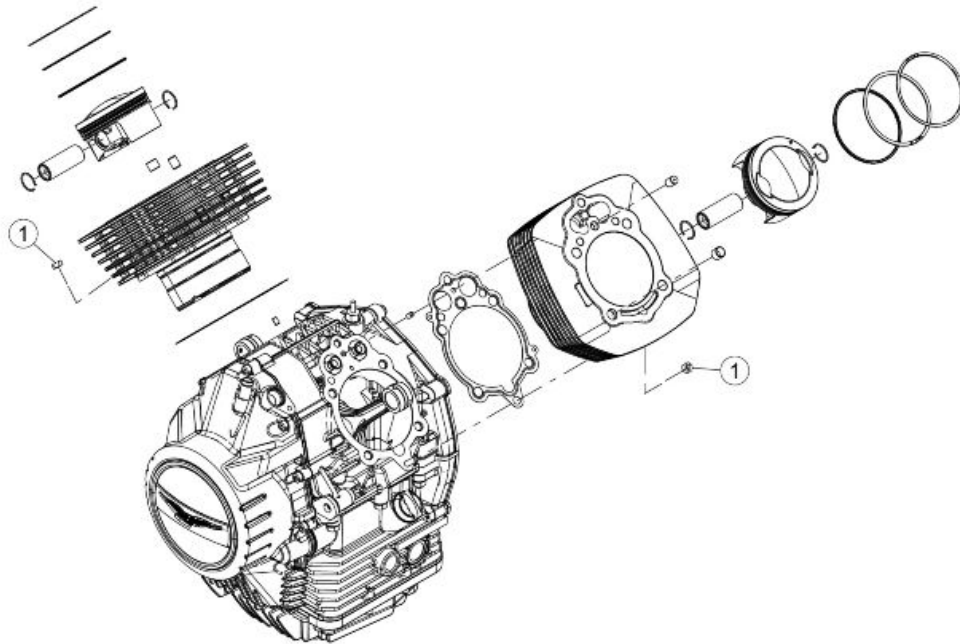

CYLINDER - PISTON

Pos.	Description	Type	Quantity	Torque	Note
1	Cylinder nut	M6	2	9-11 Nm (6.64-8.11 lb ft)	Loct. 243

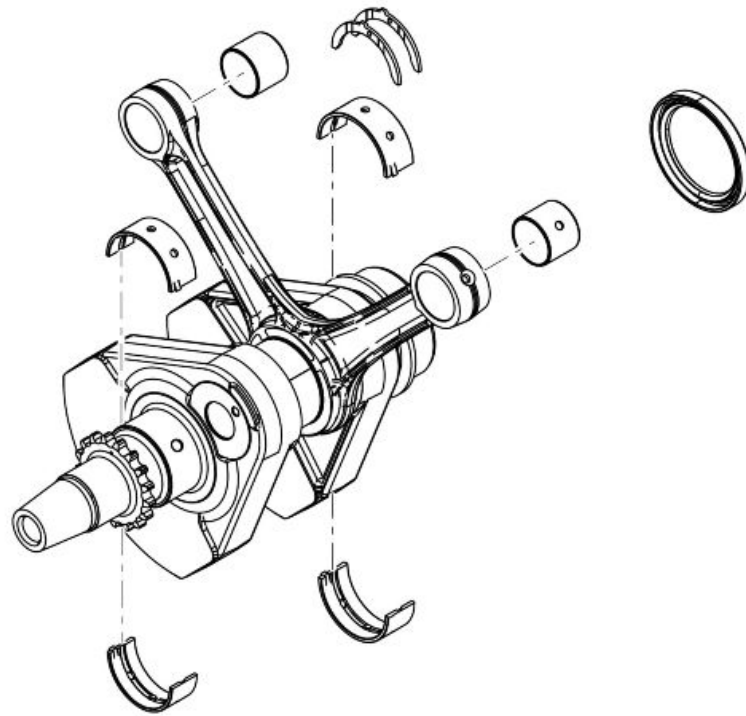

CRANKSHAFT

Pos.	Description	Type	Quantity	Torque	Note
-	Crankshaft plug	M12	1	15-18 Nm (11.06-13.28 lb ft)	Loct. 648
-	Connecting rods screws (pre-tightening 1st coupling)	M8	4	10 Nm (7.37 lb ft)	Lubricate the thread and underhead with Pankl PLB 19
-	Connecting rods screws (pre-tightening 2nd coupling)	M8	4	20 Nm (14.75 lbf ft)	Lubricate the thread and underhead with Pankl PLB 19
-	Connecting rods screws (final tightening)	M8	4	65°+/-2° - 40-70 Nm (29.50-51.73 lbf ft)	Lubricate the thread and underhead with Pankl PLB 19

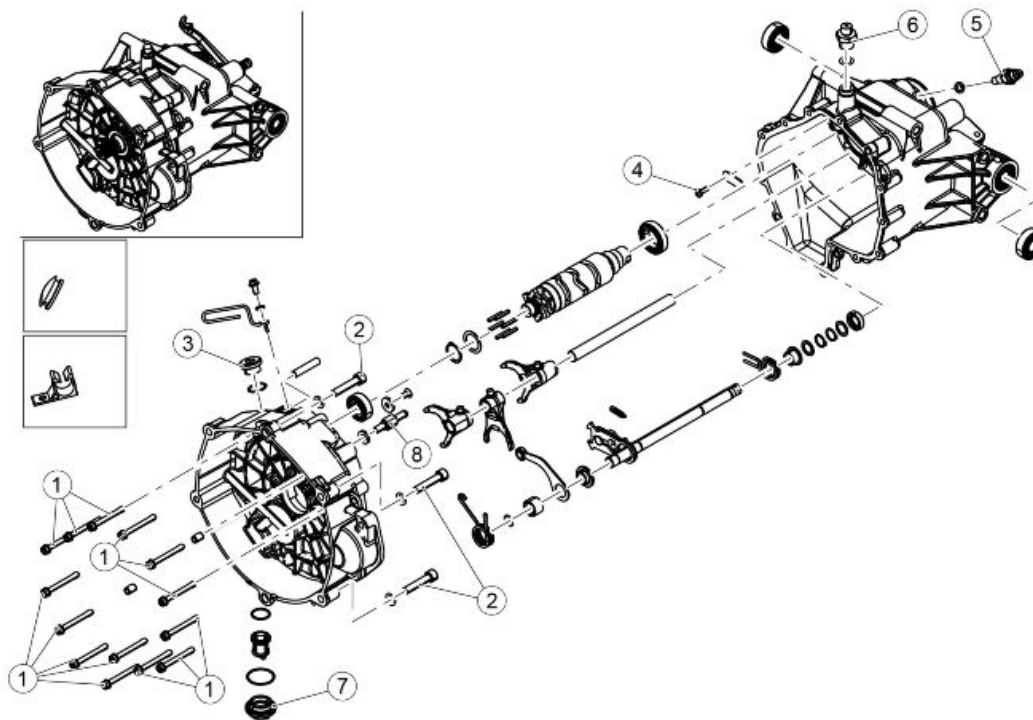

COMPLETE GEAR / SELECTOR / DESMODROMIC

Pos.	Description	Type	Quantity	Torque	Note
1	Clutch housing/gearbox fastening SHC screws	M6x55	13	9-11 Nm (6.64-8.11 lb ft)	-
2	Engine / gearbox fastening SHC screws	M8x40	6	24-28 Nm (17.70-20.65 lb ft)	-
3	Oil load cap	M20	1	23-27 Nm (16.96-19.91 lb ft)	-
4	Oil breather plate fixing Torx screw	M5x16	1	6-7 Nm (4.42-5.16 lb ft)	Pre-applied Loct.; LOCTITE 20450 or 3M 2353
5	Neutral switch	M8	1	9-11 Nm (6.64-8.11 lb ft)	-
6	Bleeder cap	M10	1	18-22 Nm (13.28-16.23 lb ft)	-
7	Gearbox oil filter cap	M28	1	25-30 Nm (18.44-22.13 lb ft)	-
8	Pre-selector pin	M8	1	20-24 Nm (14.75-17.70 lb ft)	Pre-applied Loctite; TECNOLOGIC 150 ROSSO alternative- ly LOCTITE DRI LOC 2040

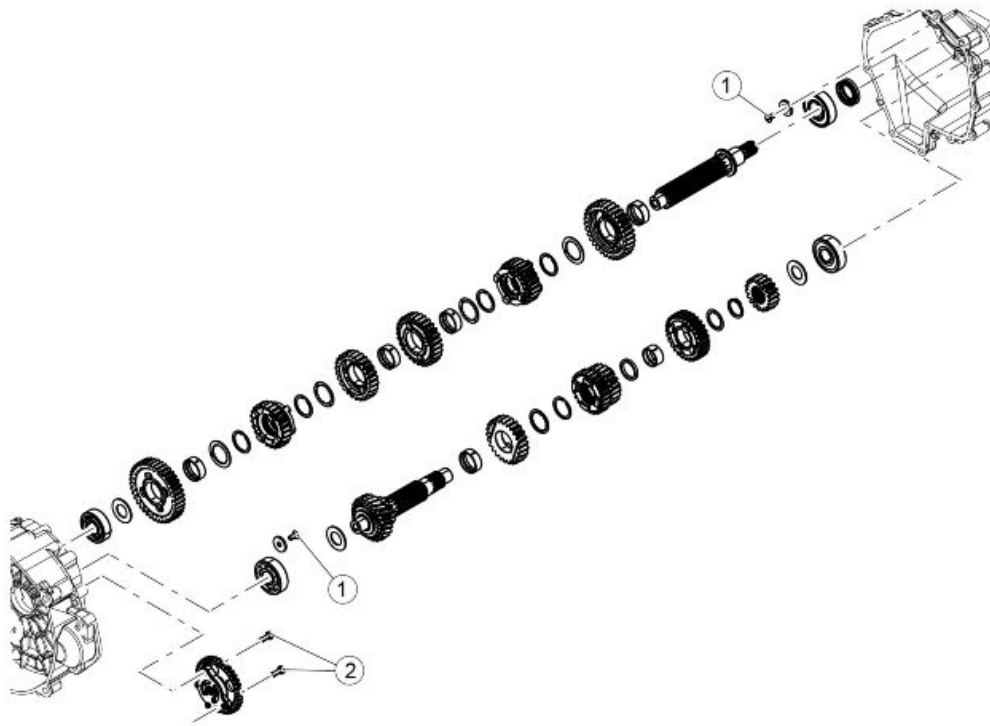

GEARBOX COMPONENTS

Pos.	Description	Type	Quantity	Torque	Note
1	Bearing stoppers countersunk hex head screws	M6x12	2	9-11 Nm (6.64-8.11 lb ft)	Pre-applied Loct.; alternatively 3M SCOTCH-GRIP 2353 or Loct. DRI LOC 2045 BLU

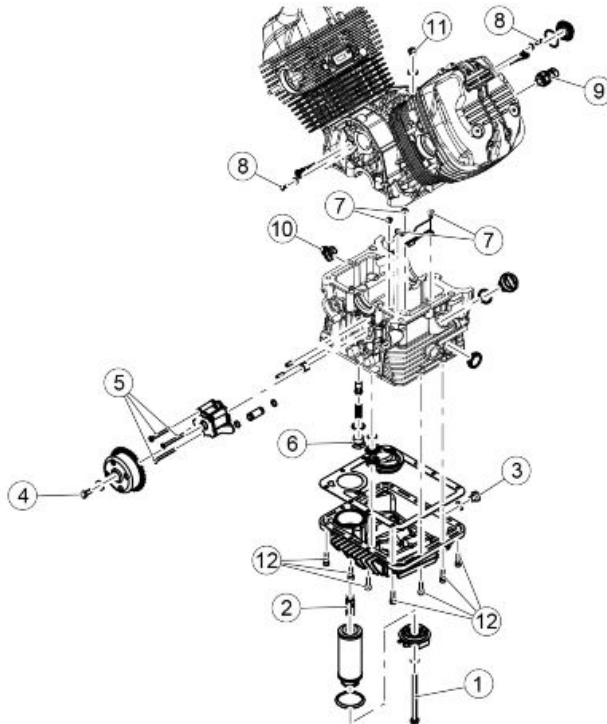

LUBRICATION

Pos.	Description	Type	Quantity	Torque	Note
1	Cover and oil filter cartridge fixing hex head screw	M8x105	1	18-22 Nm (13.28-16.23 lb ft)	-
2	Oil filter joint	M12	1	20-24 Nm (14.75-17.70 lb ft)	-
3	Oil sump drainage plug	M10	1	20-24 Nm (14.75-17.70 lb ft)	-
4	Oil pump gear flanged hex head screw	M7x18	1	16-17 Nm (11.80-12.53 lb ft)	Pre-applied Loct.; 3M SCOTCH-GRIP 2353 or PRELOK PRECOTE 80 or LOCTITE 2045
5	Oil pump countersunk head screws	M5x55	3	5-6 Nm (3.69-4.42 lb ft)	Pre-applied Loctite; 3M SCOTCH GRIP 2353
6	Oil pressure valve cap	M18	1	20-25 Nm (14.75-18.44 lb ft)	-
7	Oil scraper plate notched cylindrical head screws	M5x10	4	3-4 Nm (2.21-2.95 lb ft)	Pre-applied Loct.; Alternatively 3M SCOTCH-GRIP 2353 or PRELOK PRECOTE 80 or LOCTITE 2045
8	Cooling jet torx screw	M4x12	2	2.8-3.4 Nm (2.06-2.51 lb ft)	Pre-applied Loct.; alternatively 3M SCOTCH-GRIP 2353 or Loct. DRI LOC 2045 BLU
9	Oil temperature sensor	M10	1	18-22 Nm (13.28-16.23 lb ft)	Loct. 243
10	Minimum oil pressure sensor	-	1	20-24 Nm (14.75-17.70 lb ft)	-
11	Oil circuit cap	M10	1	18-22 Nm (13.28-16.23 lb ft)	LOCTITE 243
12	Oil sump fixing screws	M6	12	11-13 Nm (8.11-9.59 lb ft)	-
-	Cable screw on the minimum oil pressure sensor	M4	1	1.5-1.8 Nm (1.11-1.33 lb ft)	-

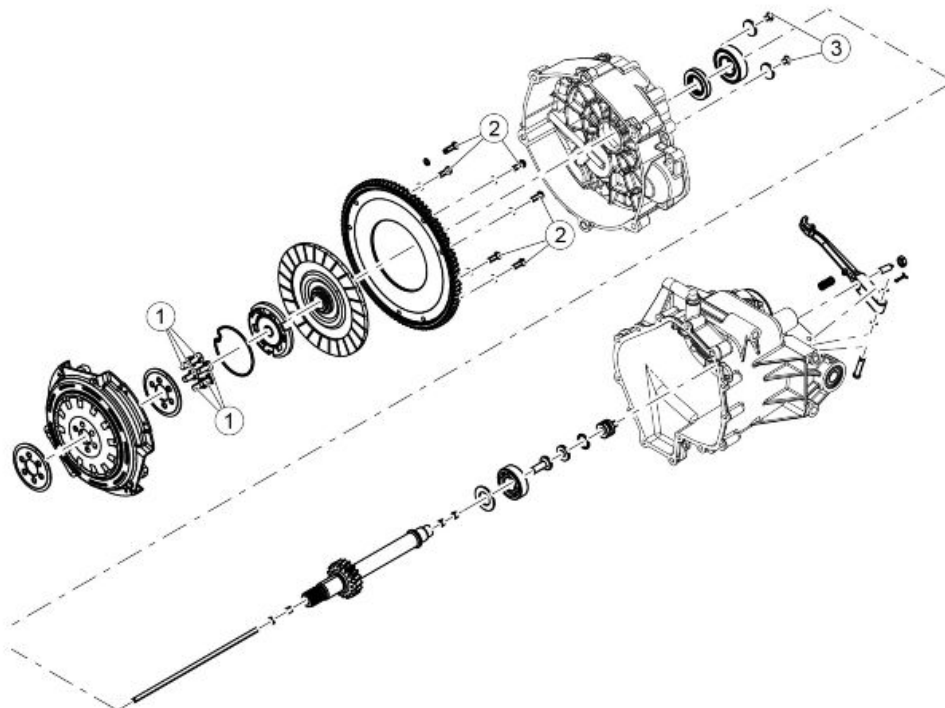

CLUTCH

Pos.	Description	Type	Quantity	Torque	Note
1	Clutch-crankshaft screws	M8	6	38-42 Nm (28.03-30.98 lb ft)	Loct. 243
2	Starter sprocket fixing torx rounded head screws	M6x20	6	9-11 Nm (6.64-8.11 lb ft)	Pre-applied Loct.; alternatively Loct. DRI-LOC 2040 or 3M SCOTCH GRIP 2353
3	Bearing stopper countersunk hex head screws	M6x12	2	9-11 Nm (6.64-8.11 lb ft)	Pre-applied Loct.; alternatively 3M SCOTCH-GRIP 2353 or Loct. DRI LOC 2045 BLU

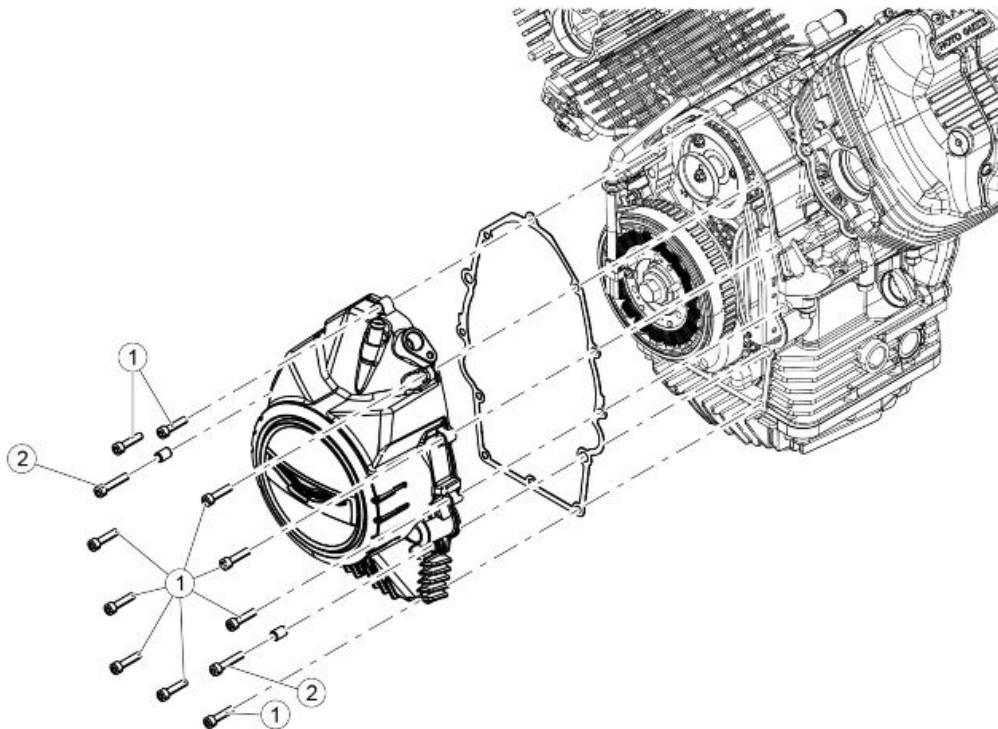

FLYWHEEL COVER

Pos.	Description	Type	Quantity	Torque	Note
1	Timing system cover screws	M6	10	9-11 Nm (6.64-8.11 lb ft)	-
2	Timing system cover screws	M6	2	9-11 Nm (6.64-8.11 lb ft)	-

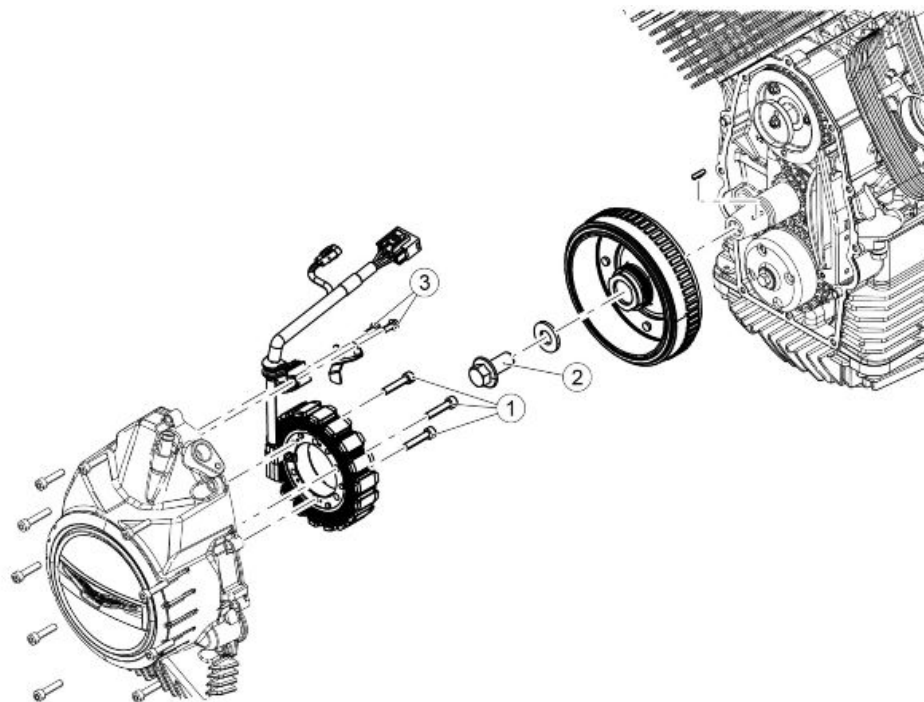

MAGNETO FLYWHEEL / START-UP

Pos.	Description	Type	Quantity	Torque	Note
1	Stator SHC screws	M6x20	3	9-11 Nm (6.64-8.11 lb ft)	Loct. 243
2	Flywheel flanged hex head screw	M14x30	1	114-125 Nm (84.08-92.19 lb ft)	-
3	Flanged hex head screws for cable clamp plate on the generator's cover	M5x12	1	5-6 Nm (3.69-4.42 lb ft)	Pre-applied Loctite

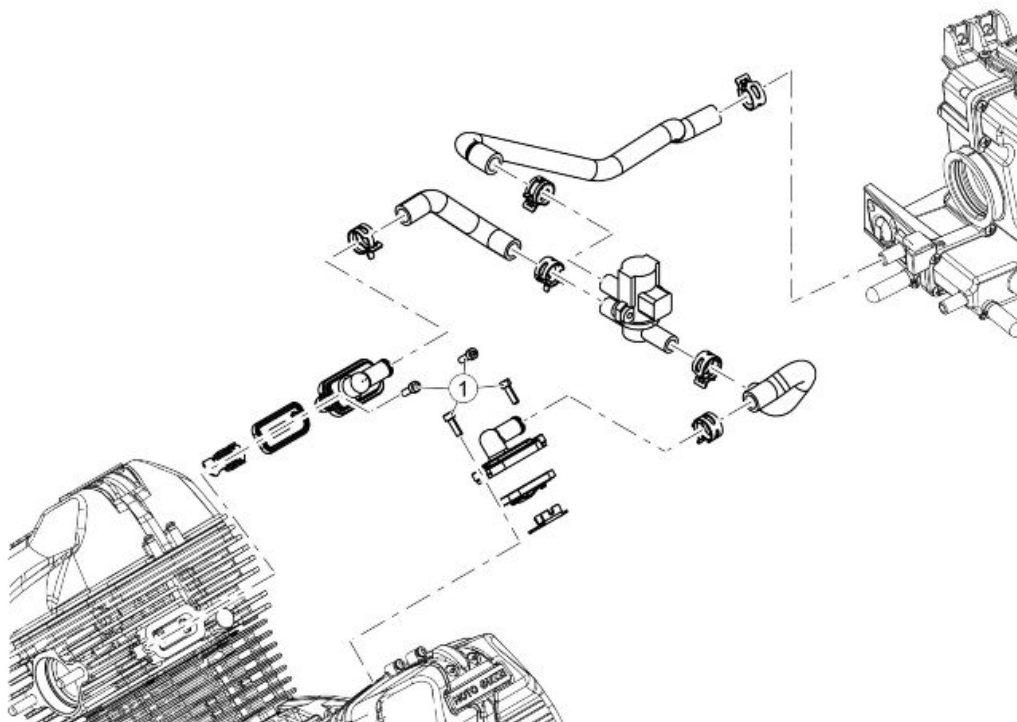

SECONDARY AIR SYSTEM





Pos.	Description	Type	Quantity	Torque	Note
1	Secondary air covers SHC screws	M5	4	3-4 Nm (2.21-2.95 lb ft)	-

INDEX OF TOPICS

SSPECIAL TOOLS

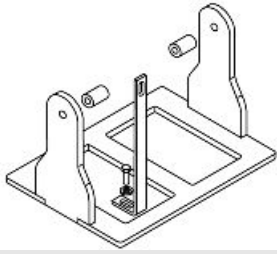
S-TOOLS

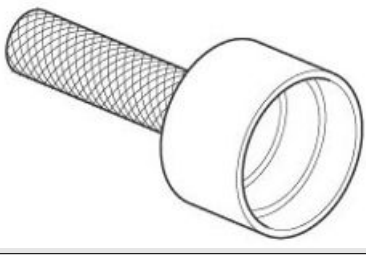
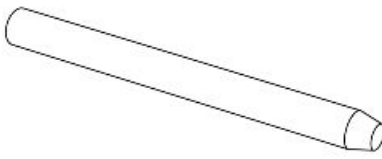
SPECIAL TOOLS

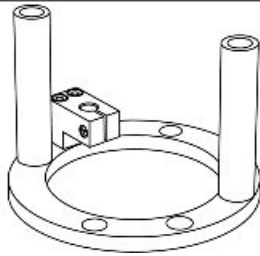
Stores code	Description	
020997Y	Engine support plate	
020382Y	Tool to extract valve cotters	
GU19927100	Tool for mounting seal ring on flange on the flywheel side	
020995Y	Rocker arm centring pin	
020128Y	Piston fitting ring	
020996Y	Piston protrusion measurement tool	

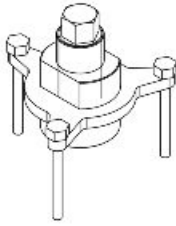
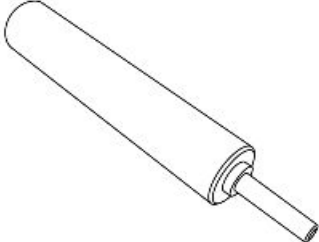
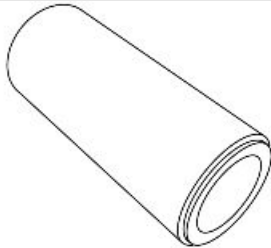
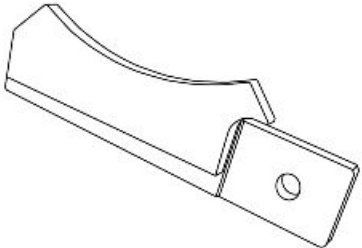
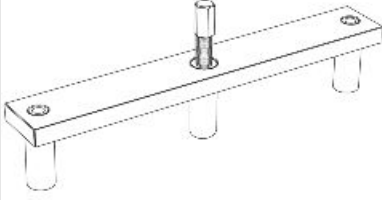
Stores code	Description	
020713Y	Flywheel extractor	 A complex mechanical tool with a central threaded shaft and several radial arms, used for extracting a flywheel.
020976Y	Clutch control dust guard mounting punch	 A long, cylindrical metal punch with a slightly tapered end and a small diameter section at the tip.
021020Y	Clutch housing oil seal mounting punch	 A cylindrical metal punch with a slightly tapered end and a small diameter section at the tip, similar to the previous punch but with a different length.
021001Y	Clutch retainer tool	 A curved metal tool with a flat base and a raised edge, used for retaining the clutch assembly.
021002Y	Clutch centring	 A long, thin metal bar with a central threaded hole and two small cylindrical protrusions at the ends, used for centering the clutch.

INDEX OF TOPICS

ENGINE

ENG

Gearbox

Diagram

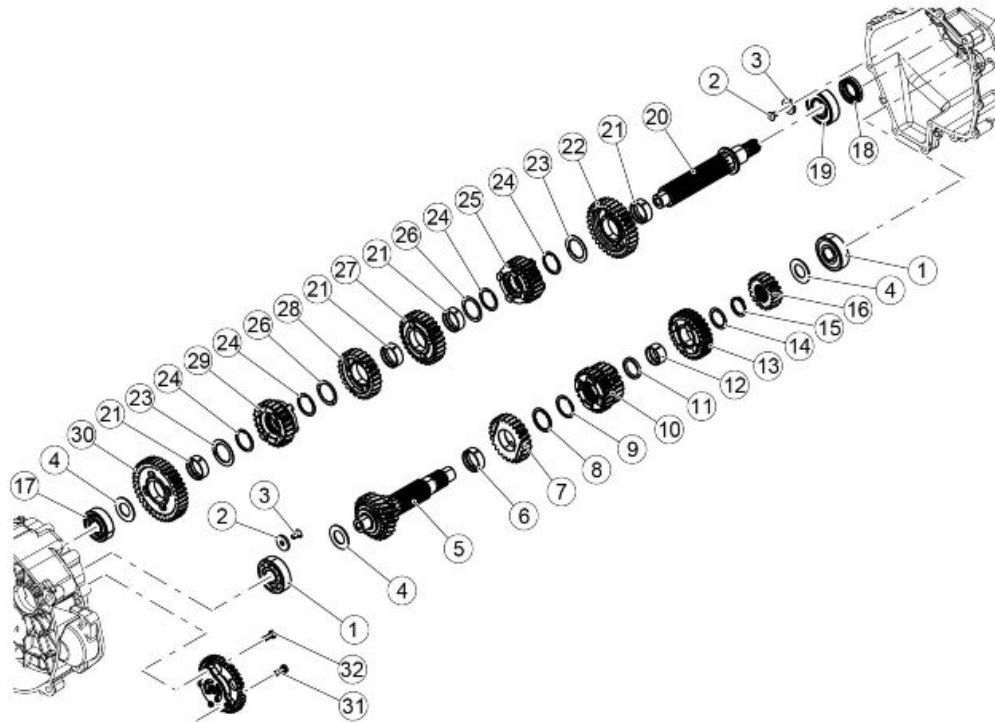

Key:

1. Ball bearing 20x52x15
2. Washer
3. countersunk hex head screw
4. Shoulder washer
5. Primary shaft
6. Floating bushing
7. 5th speed gear
8. Shoulder washer
9. Circlip for shafts
- 10.3rd-4th speed sliding gear.
- 11.Shoulder washer
- 12.Floating bushing
- 13.6th gear
- 14.Shoulder washer
- 15.Snap ring
- 16.2nd on first gear.

- 17. Ball bearing 20x47x14
- 18. Seal ring 40x25x7
- 19. Ball bearing 25x52x15
- 20. Secondary transmission shaft
- 21. Floating bushing
- 22. 2nd speed gear on transmission shaft
- 23. Shoulder washer
- 24. Circlip for shafts
- 25. 6th gear
- 26. Shoulder washer
- 27. 3rd speed gear Z=28
- 28. 4th speed gear Z=26
- 29. 5th speed gear
- 30. 1st speed gear
- 31. Compl. oil pump.
- 32. Torx screw MSx16

Gearbox

Removing the gearbox

- Remove the 5 screws (1) fixing the gearbox to the engine crankcase

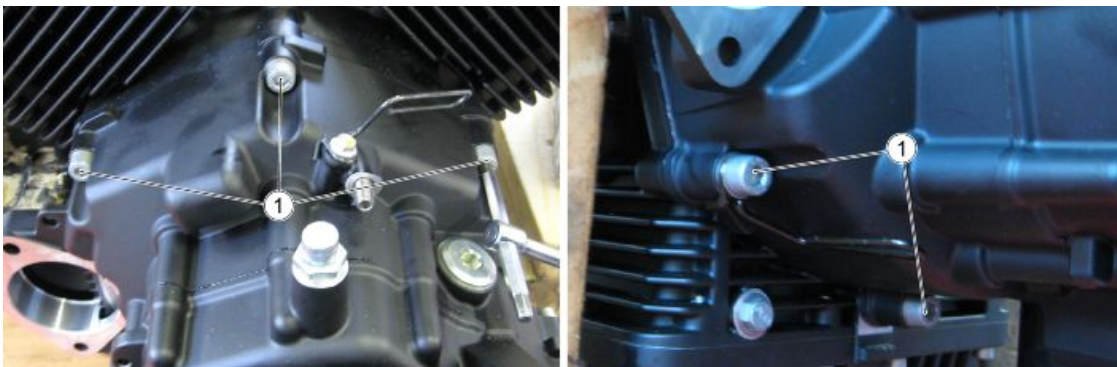

- Remove the fixing screw (2) of the gearbox, placed from the engine crankcase side



- Remove the complete gearbox screw

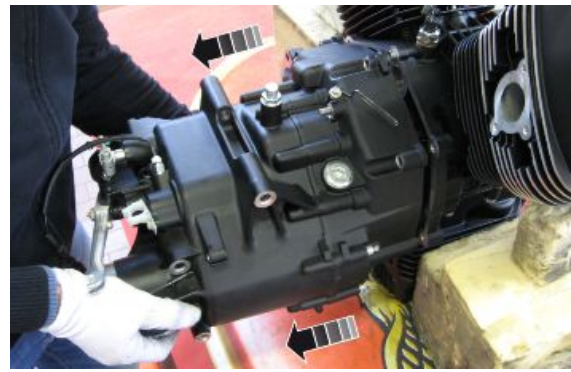

Filtro olio

- Place a container with 500 cm³ (30.51 cu in) capacity under the drainage plugs (1), remove it and then let the oil drop in the container for some minutes

NOTE

CHECK AND, IF NECESSARY, REPLACE THE DRAIN PLUG SEAL WASHER



- Remove the gear oil filter (2) and thoroughly clean it before refitting it



Gearbox shafts

Disassembling the gearbox

- Remove the 14 fixing screws of the gearbox



- Remove the pusher plate



- Remove the neutral sensor and take the gasket washer

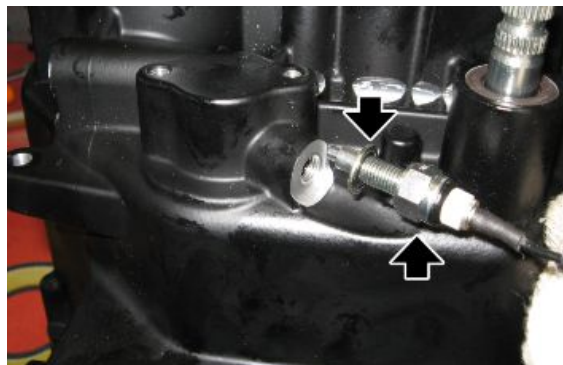

- Remove the intermediary body (1), the thrust bearing (2) and the external body (3)

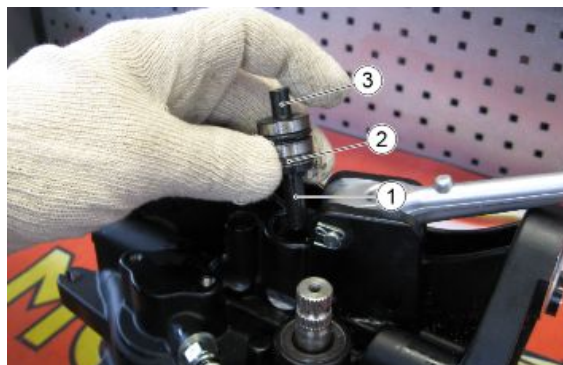

- Remove the gearbox cover with a few mallet strokes



CAUTION

CAREFULLY CLEAN THE THREEBOND FROM THE CONTACT SURFACES BEFORE APPLYING A NEW LAYER OF THREEBOND 1207B DURING THE REASSEMBLY OF THE GEARBOX.

- To remove the bearings fitted in the gearbox crankcases, the safety washer must be removed first

CAUTION

PAY ATTENTION WHEN REMOVING THE BEARING SAFETY WASHERS, THEY HAVE TWO DIFFERENT SIZES. THE SMALL WASHERS MAY BE PLACED ERRONEOUSLY INSTEAD OF THE ONES WITH LARGER SIZE

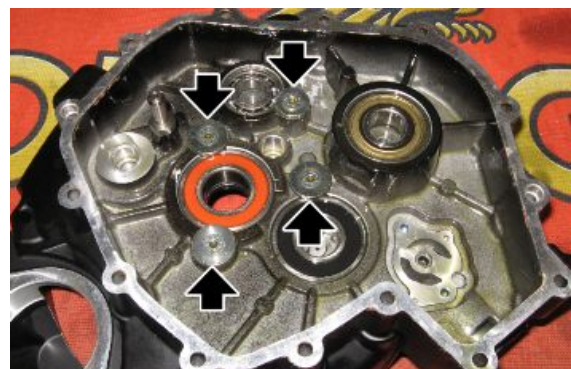

- The bearings from the gearbox crankcases can be removed using generic extractors.



- Remove the drive shaft secondary oil gaiter

CAUTION

IN CASE OF OIL SEAL REPLACEMENT, USE THE SUITABLE PUNCH UNTIL IT REACHES THE CRANKCASE

Specific tooling

020978Y Cardan secondary oil seal mounting punch



Removing the primary shaft

CAUTION

FIT NEW CIRCLIPS WHEN REASSEMBLING

- Remove the gear selector shaft, the desmodromic shaft and the forks with shaft
- Remove the complete gear unit



To dismantle the main shaft, proceed as follows:

- Remove the shim washer (1)

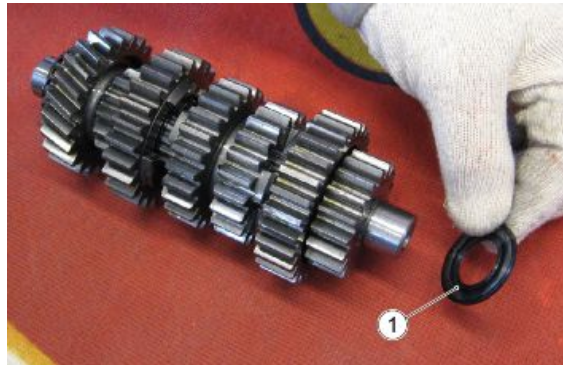

- Remove the gear of the 2nd gear (2)

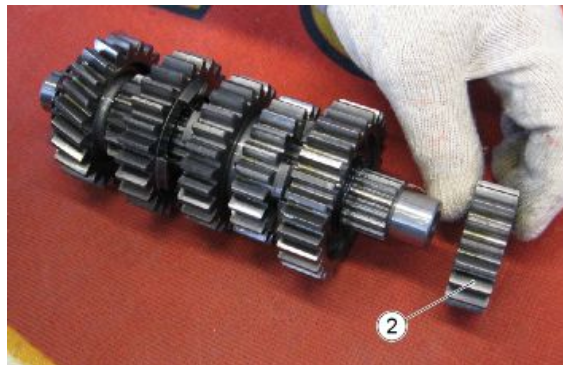

- Remove the seeger ring (3)

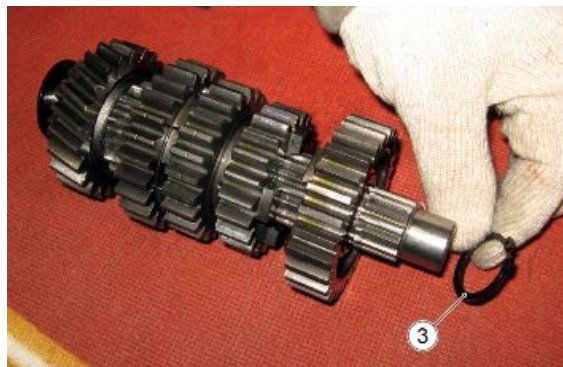

- Remove the spacer (4)

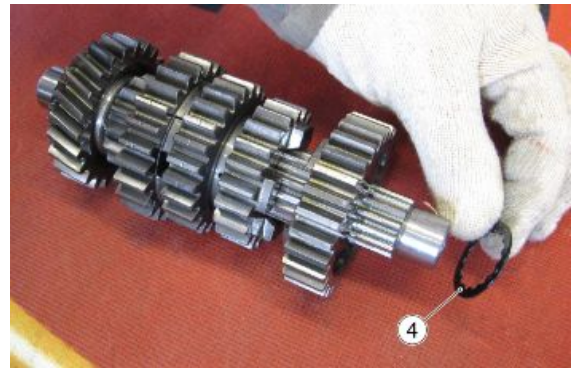

- Remove the gear of the 6th gear (5)



- Remove the bushing (6)

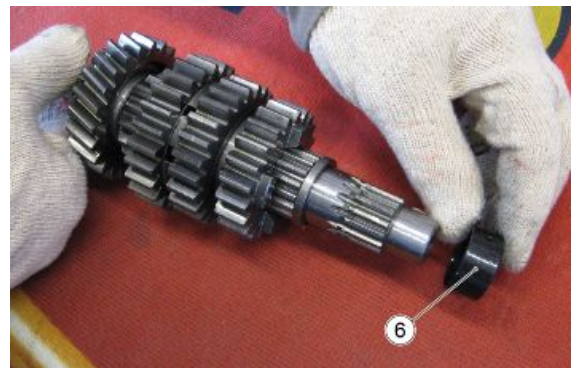

- Remove the spacer (7)

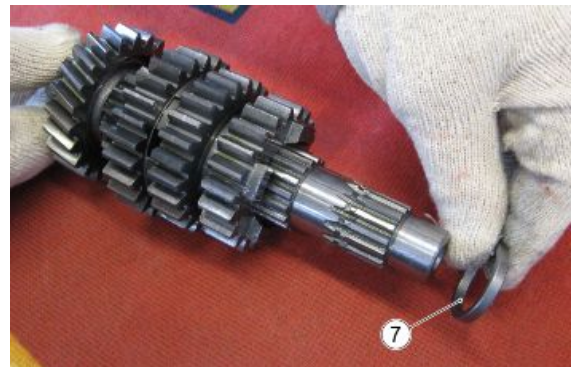

- Remove the gear of the 3-4th gear (8)

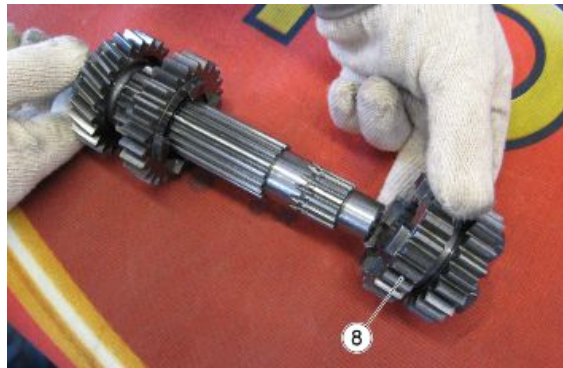

- Remove the seeger ring (9)

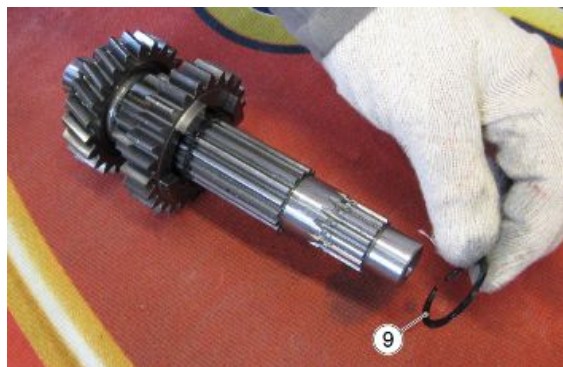

- Remove the spacer (10)

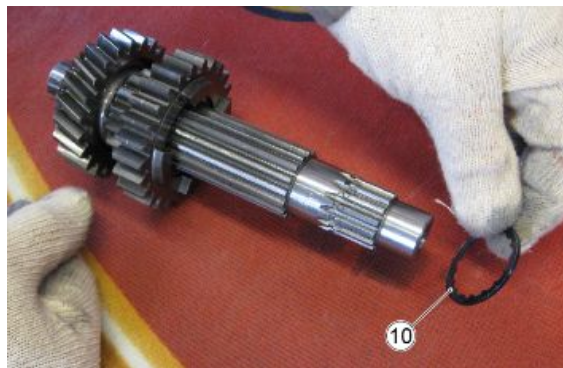

- Remove the gear of the 5th gear (11)

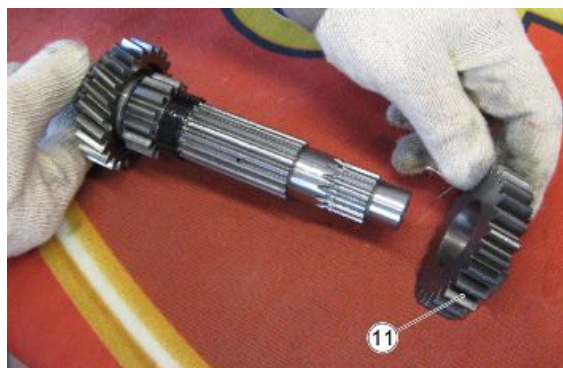

- Remove the bushing (12)

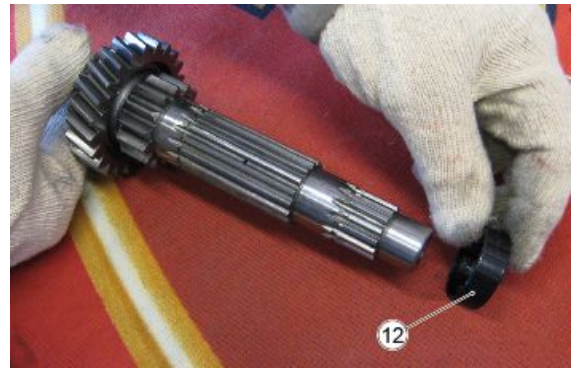

- Remove the washer (13) from the main shaft (14)



Removing the secondary shaft

CAUTION

FIT NEW CIRCLIPS WHEN REASSEMBLING

Disassemble the secondary shaft as follows:

- Remove the shim washer (1)

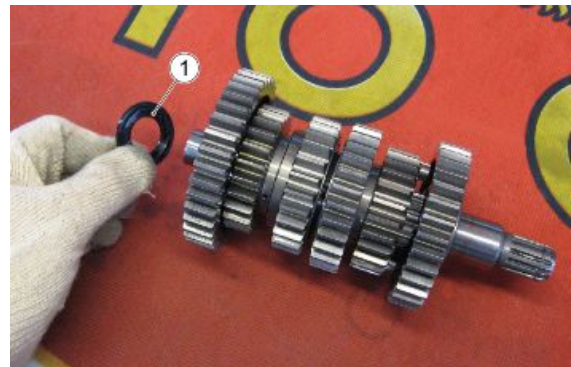

- Remove the gear of the first gear (2)



- Remove the bushing (3)

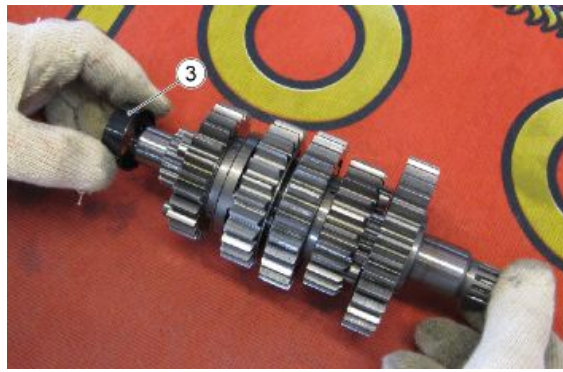

- Remove the shim washer (4)

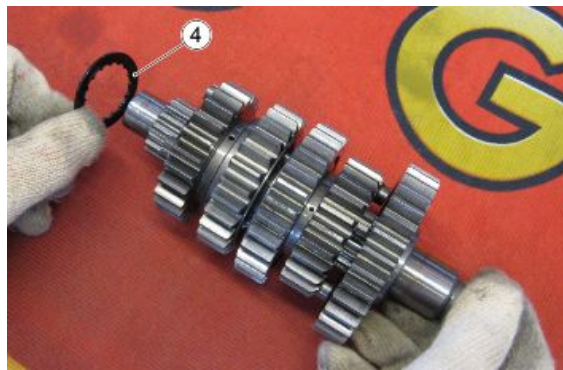

- Remove the seeger ring (5)

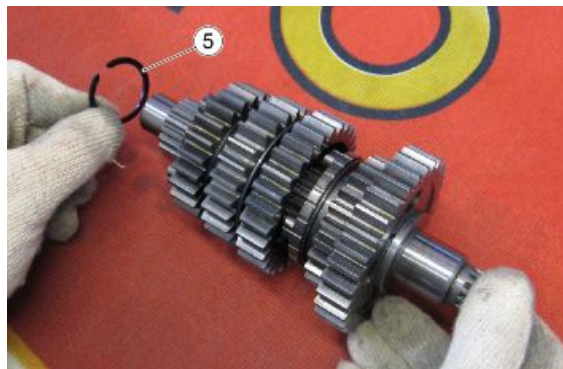

- Remove the gear of the 5th gear (6)

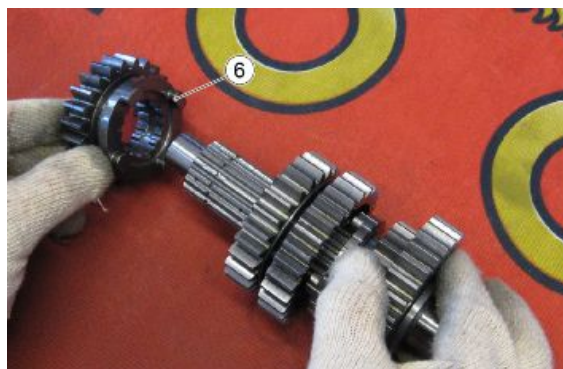

- Remove the seeger ring (7)

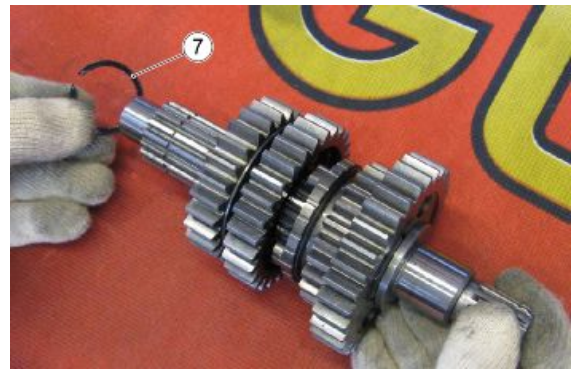

- Remove the shim washer (8)



- Remove the gear of the 4th gear (9)



- Remove the bushing (10)



- Remove the gear of the 3rd gear (11)



- Remove the bushing (12)



- Remove the shim washer (13)



- Remove the seeger ring (14)



- Remove the gear of the 6th gear (15)

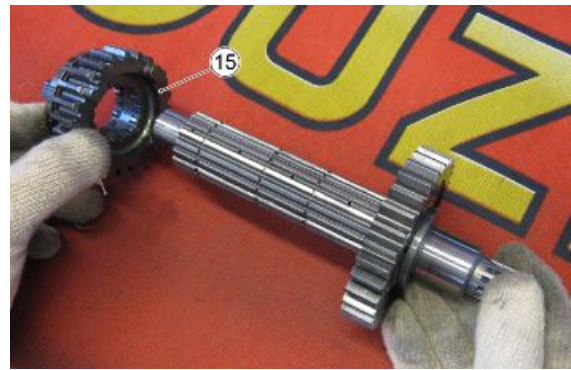

- Remove the seeger ring (16)



- Remove the shim washer (17)



- Remove the gear of the 2nd gear (18)



- Remove the bushing (19)



Desmodromic demounting

- Remove the gearbox selector
- Remove the sliding shaft of the forks (1)



- Remove the desmodromic shaft (2)



- The forks are marked with a serial number that indicated the correct positioning.
- Remove the upper fork No.1 (3)



- Remove the central fork No.2 (4)



- Remove the lower fork No.3 (5)



Disassembling the clutch shaft

- Using the appropriate specific tools, remove the clutch shaft fastening nut

Specific tooling

020975Y Clutch shaft nut cable

GU19907160 Clutch shaft sealing tool



- Remove the clutch shaft with a few mallet (1) strokes



- Remove the oil seal from the clutch shaft

CAUTION

IN CASE OF OIL SEAL REPLACEMENT, USE THE SUITABLE PUNCH UNTIL IT REACHES THE CRANKCASE

Specific tooling

020976Y Clutch control dust guard mounting punch



- Remove the spacer (2)

CAUTION

DURING REFITTING, PAY ATTENTION TO THE DIRECTION OF THE SPACER, THE CONICAL PART MUST BE ORIENTED INWARD SO AS TO AVOID O-RING DAMAGES



- Remove the O-ring (3)



- Remove the oil seal

CAUTION

IN CASE OF OIL SEAL REPLACEMENT, USE THE SUITABLE PUNCH UNTIL IT REACHES THE CRANKCASE

Specific tooling

020977Y Clutch friction oil seal mounting punch



Controllo alberi

Check transmission gears for signs of pitting and wear and replace damaged gears if necessary.
 Check the gear fitting teeth for cracks, damage and wear and replace those damaged if necessary.
 Check the transmission gears movement and, if it is not regular, replace the damaged part.

WEAR LIMITS

Specification	Desc./Quantity
Maximum wear limit for the selection gear grooves	22.78 mm (0.896 in) with rollers diam. 3.5 mm (0.14 in)
Minimum wear limit of the cardan shaft side secondary shaft seats	23.294 mm (0.9171 in) with rollers diam. 3.0 mm (0.12 in)
Minimum wear limit of the clutch side primary and secondary shaft seats	24.112 mm (0.9493 in) with rollers diam. 2.0 mm (0.08 in)

Checking the desmodromic drum

Check the desmodromic drum for damage, scratches and wear and replace the assembly if required.

Checking the forks

Check that the forks have the work surface well smooth and not worn, so to lose its quenching characteristics and that the nibs that are working in the drum grooves are not too worn, otherwise replace the forks.

CHARACTERISTICS OF THE FORKS

Specification	Desc./Quantity
Maximum selection fork axial clearance	0.3 mm (0.012 in) on the forks and 0.5 mm (0.020) on the middle slide
Minimum wear limit of the selection fork guide pins	13.973 mm (0.5501 in)

Gear selector

Removing the gear selector

- Remove the complete gearbox selector shaft from the crankcase (1)



- Remove the spring from the index lever (2)

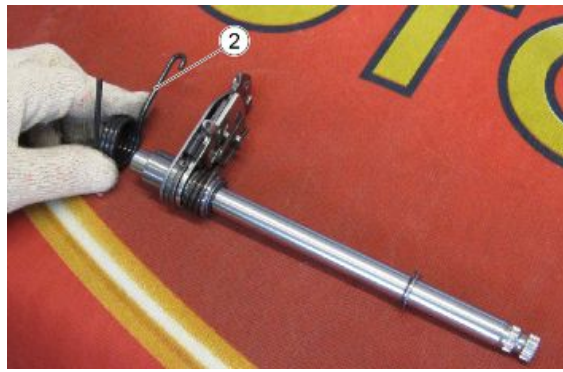

- Remove the washer (3)



- Remove the ring (9)



- Remove the seeger ring (5)

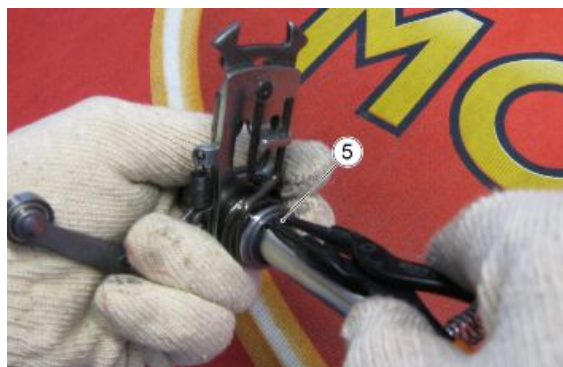

- Remove the washer (6)

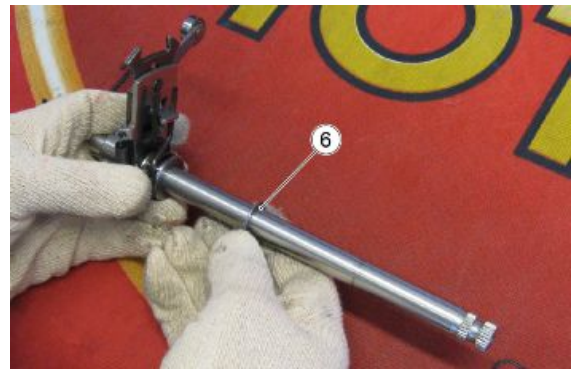

- Remove the bushing (7)

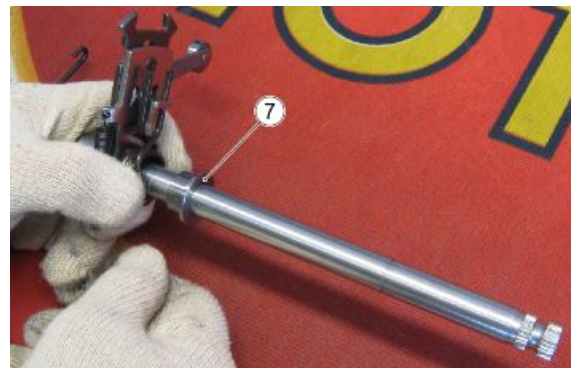

- Remove the selector spring (8)

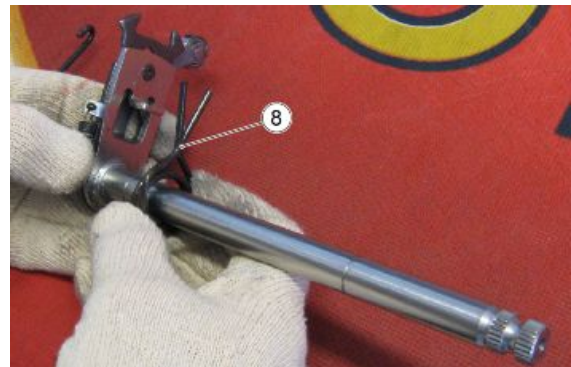

- Remove the ring (9)



- Remove the bushing (10)

WARNING

DURING REFITTING, PAY ATTENTION TO THE CORRECT POSITIONING OF THE BUSHING, AS THE SIDES ARE NOT SYMMETRICAL



- Remove the index lever (11)

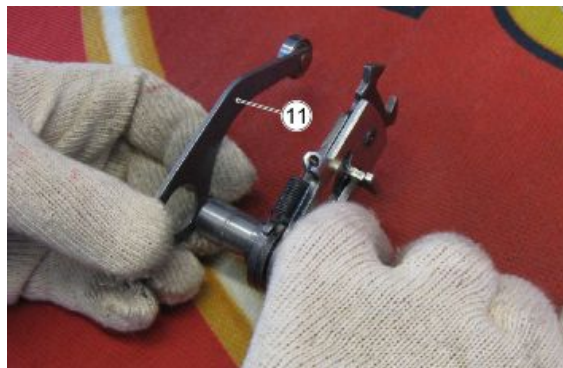

- Remove the bushing (12)

WARNING

DURING REFITTING, PAY ATTENTION TO THE CORRECT POSITIONING OF THE BUSHING, THE SIDES ARE NOT SYMMETRICAL



- Remove the selector return spring (13)

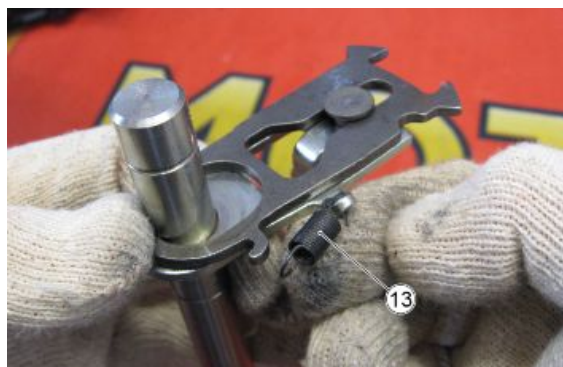

Generatore

Generator removal

ALTERNATOR COVER REMOVAL

- Remove the alternator cover fixing screws
- Remove the cover from the engine



- Remove the gasket.



ROTOR REMOVAL

- From the clutch side, partially unscrew the two fixing screws of the clutch plate, as indicated, to allow the correct positioning of the specific clutch lock tool.

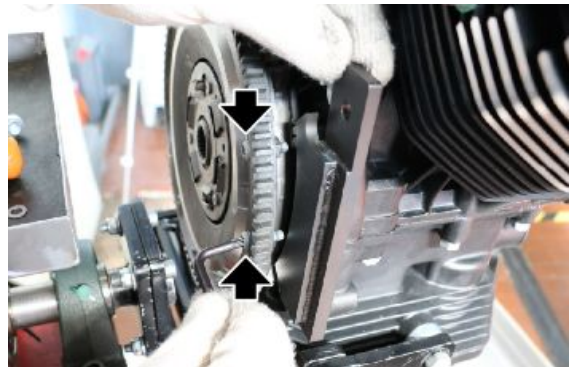

Specific tooling

021001Y Clutch retainer tool

- Using one of the fixing screws of the gearbox assembly, secure the specific tool.

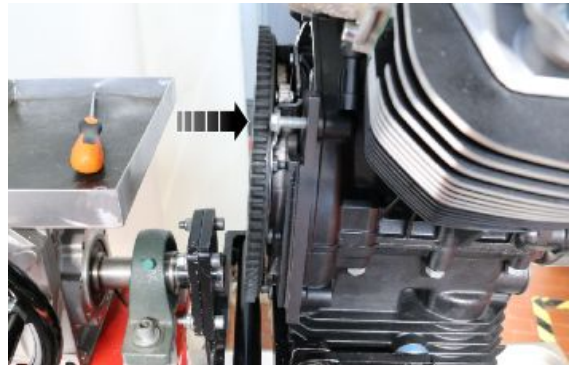

- Remove the screw fixing the rotor to the crankshaft



- Place the tool (1) on the rotor, tighten the threaded pin (2) of the tool and proceed with the rotor removal

Specific tooling

020713Y Flywheel extractor



- Remove the rotor



- Retrieve the rotor wrench from the crankshaft



STATOR REMOVAL

- Remove the two pick-up plate fixing screws



- Remove the three fixing screws fastening the stator to the timing system cover
- At this point, the stator can be removed from the cover, together with the wiring harness and the pick-up



Generator Installation

- During refitting of the flywheel cover it is necessary to apply a great amount of threebond on the cable grommet of the stator before placing it in its seat

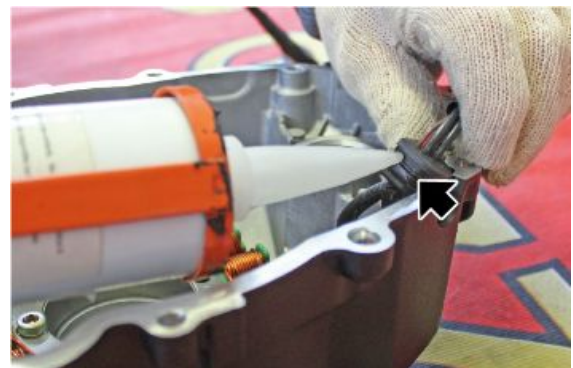

- Check that plentiful threebond leaks out and covers all space between the seat on the cover and the cable grommet. Apply another layer of threebond over the cable grommet.



- Refit a new gasket.

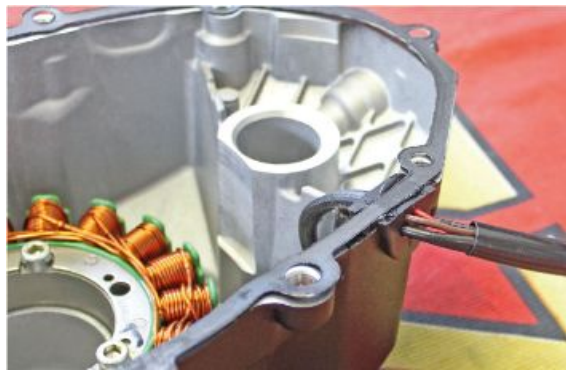

Starter motor

Removing the starter motor

- Remove the starter motor fixing screws (1)



- Remove the supporting clamp of the protection (2) and the starter motor (3)

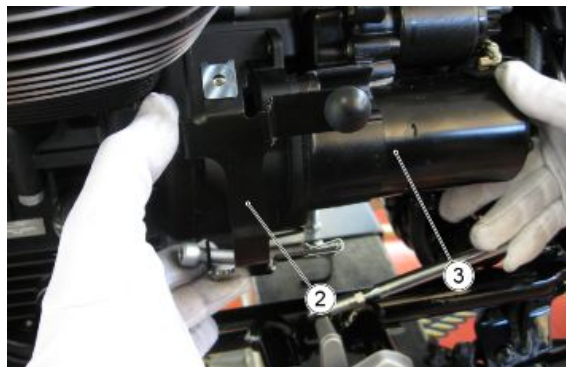

Clutch side

Disassembling the clutch

- Partially loosen the two fixing screws of the clutch plate, as indicated in the figure, to allow the correct positioning of the specific clutch lock tool

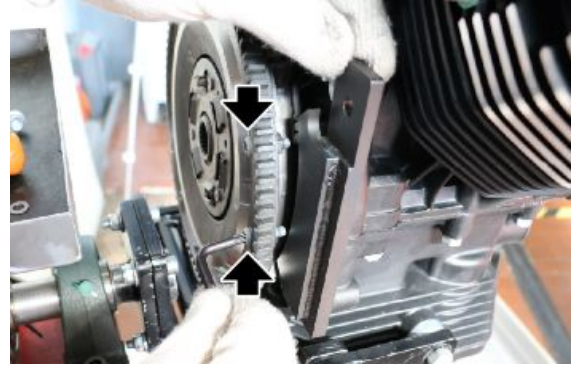

Specific tooling

021001Y Clutch retainer tool

- Using one of the fixing screws of the gearbox assembly, secure the specific tool.

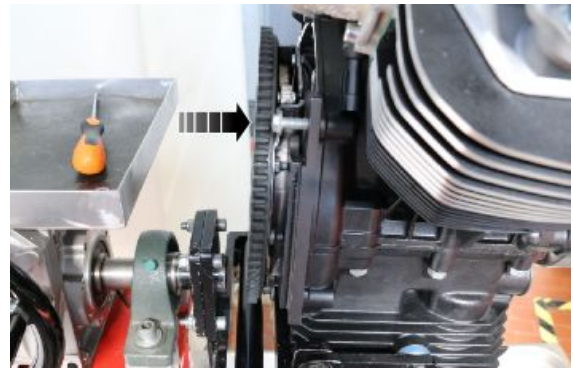

- Remove the 6 fixing screws of the clutch plate complete with starter sprocket

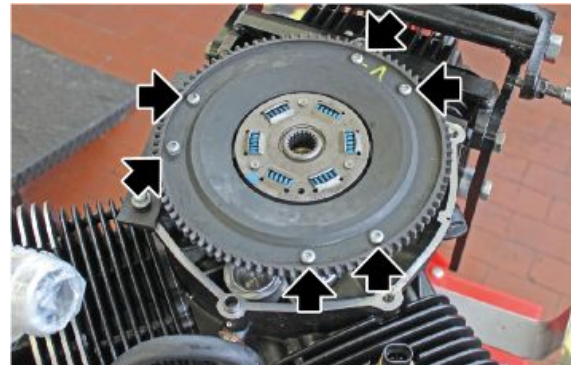

- Remove the clutch plate complete with starter sprocket

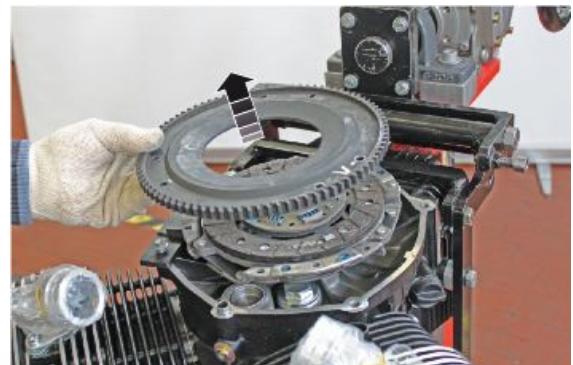

- Remove the clutch disc.



- Remove the retainer ring



- Remove the thrust plate



- Remove the 6 fixing screws of the locking plate



- Remove the reinforcement flange of the clutch thrust plate



- Remove the clutch lock complete



- Remove the spacer plate.



Checking the clutch plates

Clutch disc

Make sure that the clutch plate is not scratched or badly worn. Check the flexible springs and the thickness of the clutch disc

Characteristic

Minimum disc wear thickness

0.9 mm (0.04 in)

Starting sprocket

Check that the supporting surface with the driven plate is perfectly smooth and even.

Also check that the tooting where the starter motor pinion works is not chipped or scratched; otherwise, replace it.



Assembling the clutch

- Insert the spacer plate on the crankshaft.

NOTE

THE ROUNDED SIDE OF THE CAP MUST FACE THE GEAR-BOX



- Insert the complete clutch lock.



- Place the reinforcement cap of the clutch thrust plate, aligning the holes with the ones of the clutch base

NOTE

THE ROUNDED SIDE OF THE CAP MUST FACE THE GEAR-BOX



- Insert the 6 fastening screws complete with washers and tighten to the prescribed torque



- Insert the thrust plate cap



- Lock the thrust plate using the special lock ring

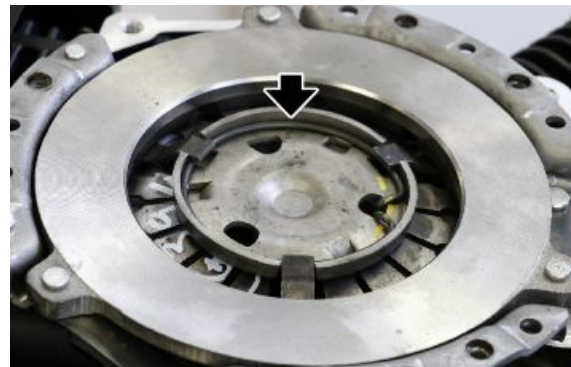

- Place the clutch plate



- Place the starter sprocket and screw the fixing screws by hand

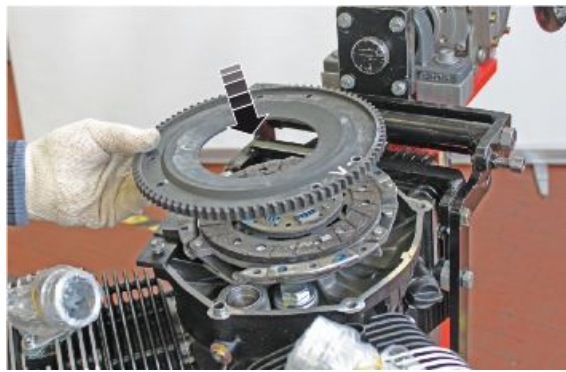

- Using the special tool for the centring of the clutch plate

Specific tooling

021002Y Clutch centring



- Insert the six fastening screws at the recommended torque.



Bushing selection

CRANKSHAFT - CRANKCASE BUSHINGS

The crankcase class is stamped in the following locations:

- Alternator side, on the upper crankcase in correspondence with the crankshaft hole, on the left.
- Clutch side, on the upper crankcase in correspondence with the crankshaft hole, on the right.

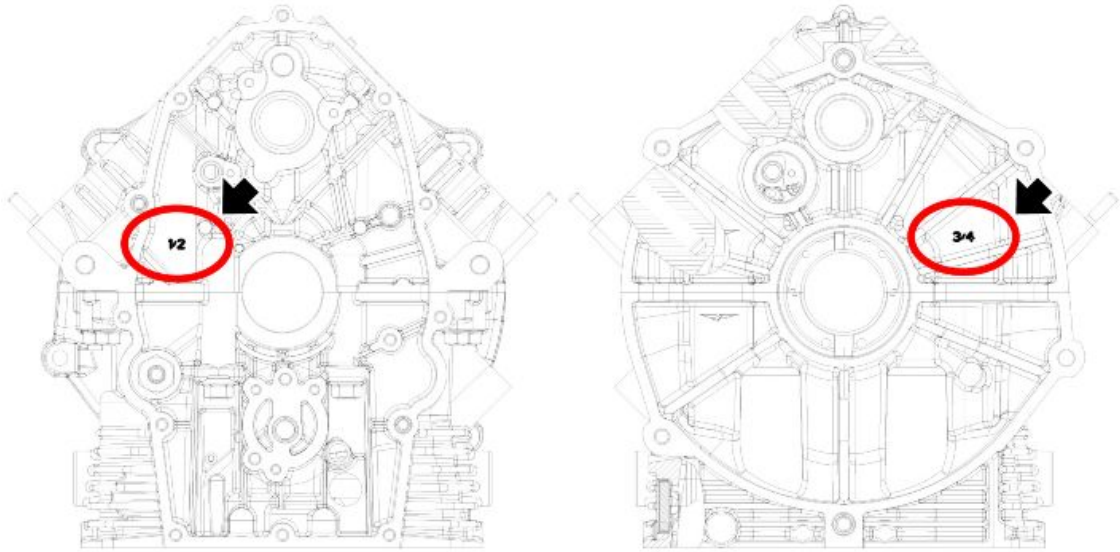

CRANKCASE HOLE DIAMETER

Specification	Desc./Quantity
Class 1	Bushing seat diameter: 43.657-43.663 mm (1.7188-1.7190 in)
Class 2	Bushing seat diameter: 43.664-43.670 mm (1.7191-1.7193 in)
Class 3	Bushing seat diameter: 47.130-47.136 mm (1.8555-1.8557 in)
Class 4	Bushing seat diameter: 47.137-47.142 mm (1.8558-1.8560 in)

Four different crankcase classes are available:

- (1-2) according to diameter of hole in half crankcase shells on alternator side.
- (3-4) according to diameter of hole in half crankcase shells on clutch side.

CRANKSHAFT

Based on the development and improvement process, the crankshaft categories can be stamped on the crankshaft counterweights (figure A)

(A)

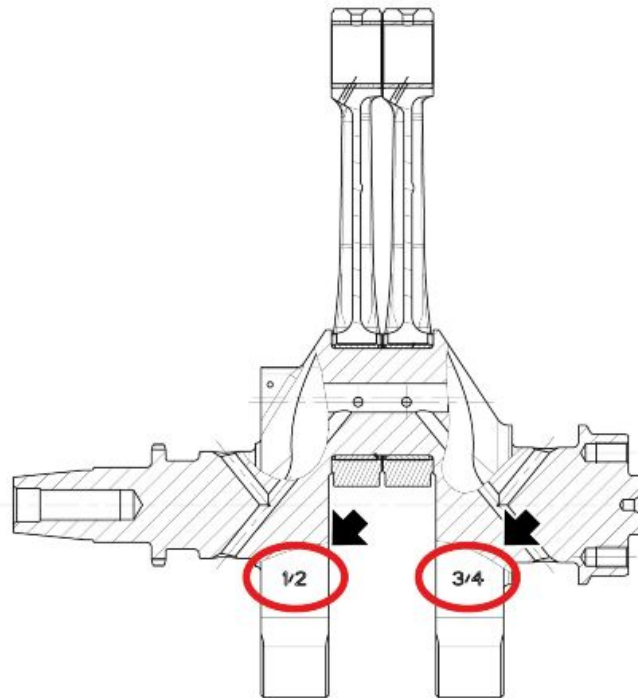

Or alternatively, laterally on the counterweights of the crankshaft (figure B)

(B)

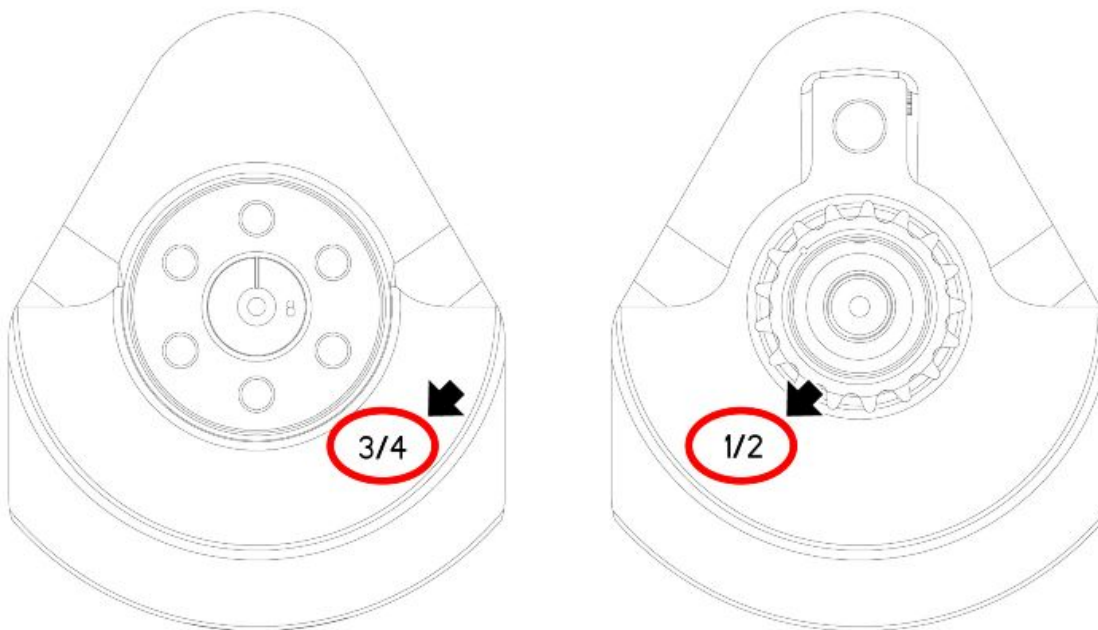

MAIN CRANKSHAFT JOURNAL DIAMETER

Specification	Desc./Quantity
Class 1	Diameter: 40.004-40.012 mm (1.5750-1.5753 in)
Class 2	Diameter: 40.013-40.020 mm (1.5753-1.5756 in)
Class 3	Diameter: 43.007-43.015 mm (1.6932-1.6935 in)
Class 4	Diameter: 43.016-43.023 mm (1.6935-1.6937 in)

Four different crankshaft classes are available:

- (1-2) according to main journal diameter on alternator side.
- (3-4) according to main journal diameter on clutch side.

SELECTING CRANKSHAFT - CRANKCASE BUSHING CLASSES

Crankcase class	Class 1 crankshaft	Class 2 crankshaft	Class 3 crankshaft	Class 4 crankshaft
Class 1	green-green	yellow-yellow	-	-
Class 2	black-black	green-green	-	-
Class 3	-	-	green-green	yellow-yellow
Class 4	-	-	black-black	green-green

Head and timing

Removing the head cover

NOTE

THE OPERATIONS FOR THE REMOVAL OF THE HEAD COVER ARE THE SAME FOR BOTH SIDES

- Remove the four fixing screws of the spark plug cover
- Remove the spark plug from the head

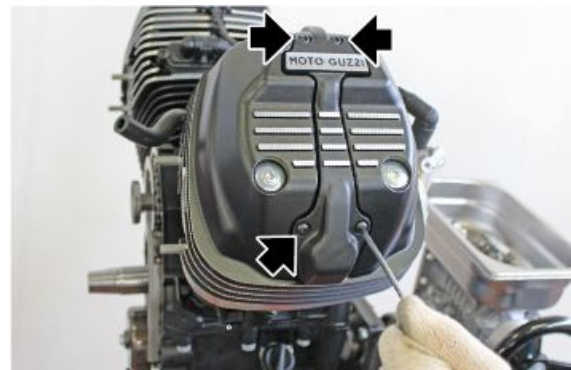

- Disconnect the spark plug tube and remove it from the head
- Unscrew the three fixing screws of the head cover and remove the related gaskets



- Remove the head cover together with the gaskets



- Remove the gasket from the head cover



- Check that the mating faces that contact the heads are not damaged or blistered

Removing the cylinder head

NOTE

THE HEAD REMOVAL OPERATIONS REFER TO ONE HEAD BUT APPLY TO BOTH

- Remove the head cover
- Unscrew the spark plug



- Bring the cylinder of the left piston to the top dead centre
- Check that the punching on the crankshaft pinion (1) is aligned with the punching on the timing system sprocket (2). The timing system punching can be seen through the hole of the chain guide cap

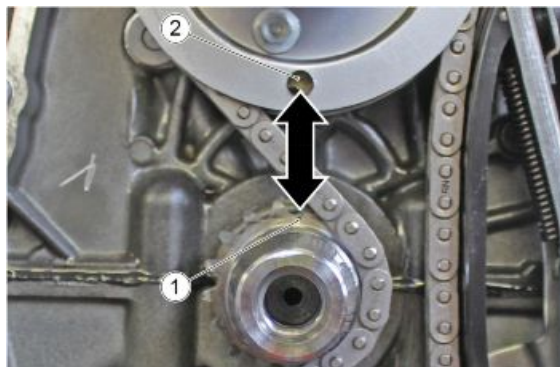

- Remove the fastening screw of the rocker pin retainer fork

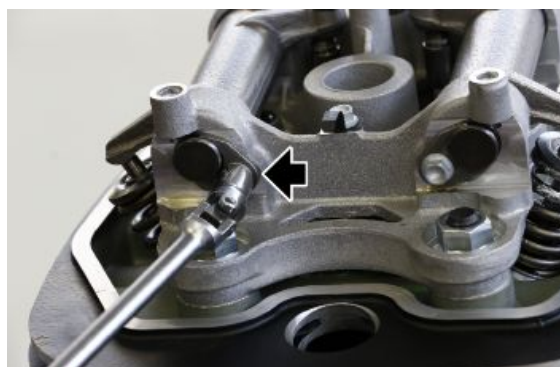

- Remove the rocker pin retainer fork

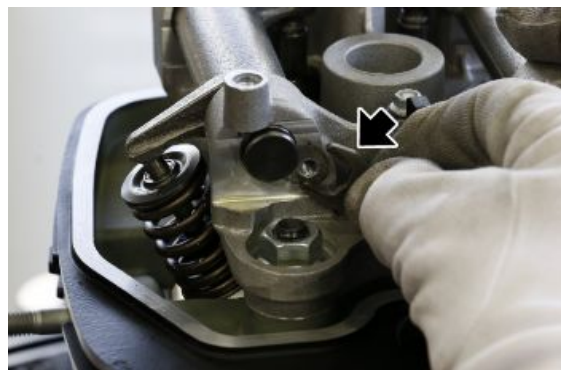

- Remove the rocker pin



- Remove the rocker, being careful to recover the Belleville spring

NOTE

REPEAT THE SAME PROCEDURE TO REMOVE THE OTHER ROCKER

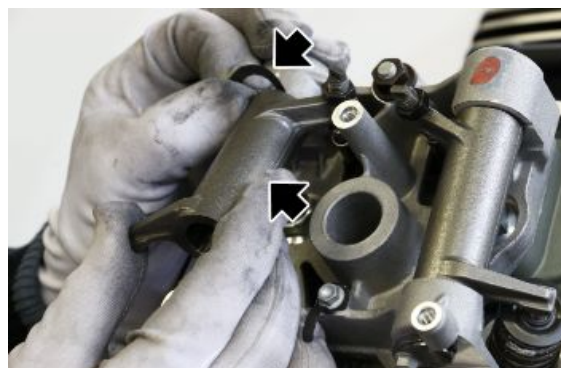

- Remove the rocker rods



- Remove the secondary air tube.



- Remove the nut with relevant washer of the cylinder to the crankcase



- Unscrew and remove the compensation nut of the cam tower



- Undo and remove the fastening nuts of the cam tower

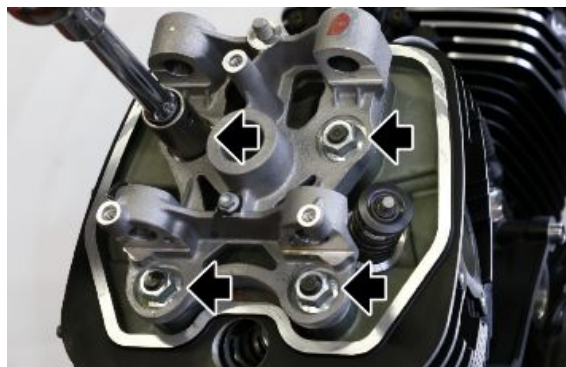

- Remove the cam tower



- Remove the three rubber O-Rings

CAUTION



PAY SPECIAL ATTENTION THAT THE O-RINGS DO NOT ACCIDENTALLY FALL INTO THE PROCESSING HOLES OF THE ROCKERS RODS

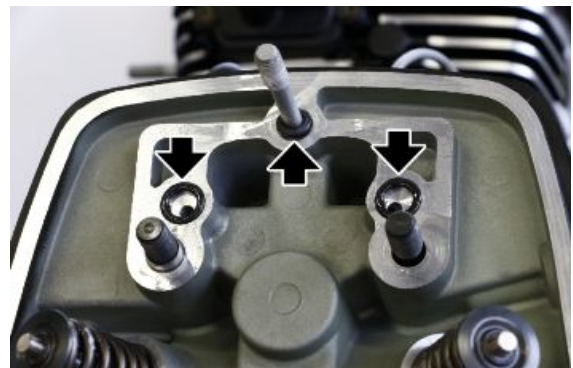

- Remove the complete head



- Remove the cylinder head gasket



- Undo and remove the secondary air valve cover

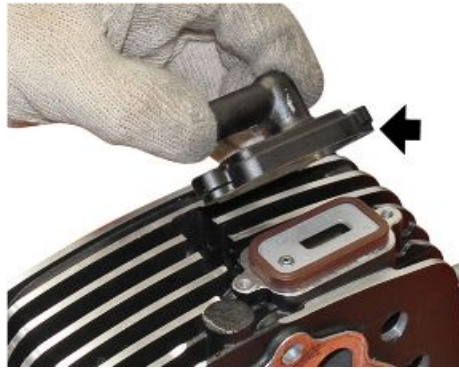

- Remove the secondary air valve
- check and if necessary replace the external rubber gasket



- Remove the internal filter paying attention to the direction during refitting



Cylinder head

Removing the valves

- Place the special tool on the upper cap of the valve to be removed and at the centre of the head of the valve.

Specific tooling

020382Y Tool to extract valve cotters



- Close the tool to compress the spring and remove the two half-cones from the upper cap

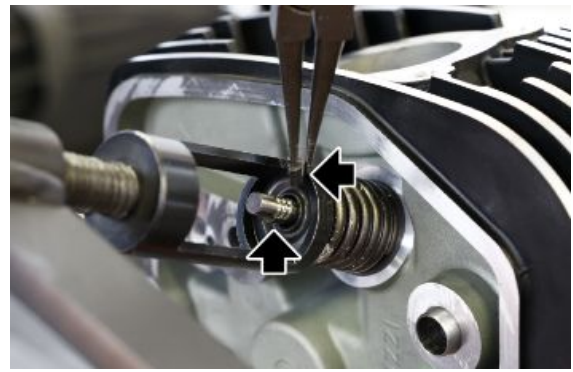

- Unscrew the tool and remove it from the head
- Remove the upper cap



- Remove the spring and replace it if it is out of the wear limit.



- Remove the valve from the head



- Remove the gasket of the valve guide



VALVE GUIDES MUST BE REPLACED WHEN THEY ARE WORN TO THE POINT THAT REPLACING THE VALVE ALONE IS NOT ENOUGH TO ELIMINATE CLEARANCE BETWEEN VALVE STEM AND VALVE GUIDE BORE.



- Remove the lower cap of the spring



Checking the rocker arms

- Check that the bolt surface that contacts the rockers is not exceedingly worn.
- Check the rocker to valve and rocker to rod contact surfaces.



Valve check

If the below shown values are out of the limits of the component wear, replace it

Intake valves:

Characteristic

Coupling clearance between valve and guide (WEAR LIMIT)

0.05 mm (0.0020 in)

Valve stem distortion (MEASURED ON 45°)

0.03 mm (0.0012 in)

Valve stem diameter (MINIMUM WEAR VALUE)

5.95 mm (0.2342 in)

Valve head eccentricity (MAXIMUM ALLOWED VALUE)

0.05 mm (0.0020 in)

Outlet valves:

Characteristic

Coupling clearance between valve and guide (WEAR LIMIT)

0.06 mm (0.0024 in)

Valve stem distortion (MEASURED ON 45°)

0.03 mm (0.0012 in)

Valve stem diameter (MINIMUM WEAR VALUE)

5.92 mm (0.2331 in)

Valve head eccentricity (MAXIMUM ALLOWED VALUE)

0.05 mm (0.0020 in)

Inspecting the springs and half-cones

- Check that the upper spring caps and the half-cones show no signs of abnormal wear.
- Check the unloaded spring length.

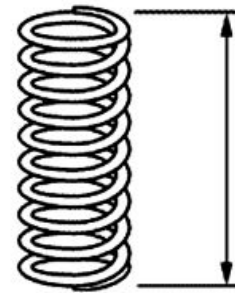

Characteristic

Spring free length (WEAR LIMIT)

45.9 mm (1.81 in)

Adjusting valve clearance

- Bring the cylinder of the left piston to the top dead centre
- Check that the punching on the crankshaft pinion (1) is aligned with the punching on the timing system sprocket (2). The timing system punching can be seen through the hole of the chain guide cap

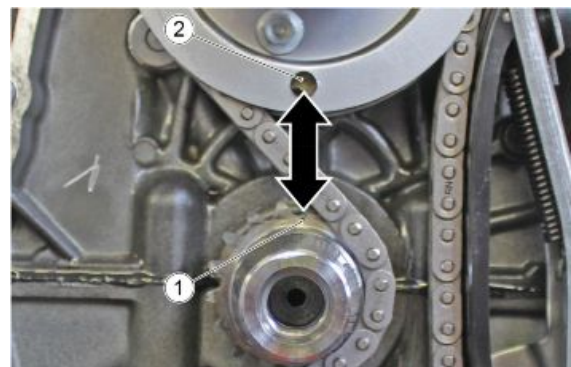

- Use a feeler gauge to check that the clearance between the valve and the set screw corresponds with the indicated values. The corresponding intake and outlet valve clearances are different than what is indicated below, proceed with adjusting them.

**Characteristic****Intake valve clearance**

0.10 mm (0.0039 in)

Exhaust valve clearance

0.15 mm (0.0059 in)

- Loosen the lock nut, adjust the clearance by acting on the adjuster until reaching the prescribed values
- Tighten the lock nut

**Timing****Removing the chain tensioner**

- Remove the timing system cover
- Remove the flywheel
- Remove the chain tensioner fixing screw recovering the washer

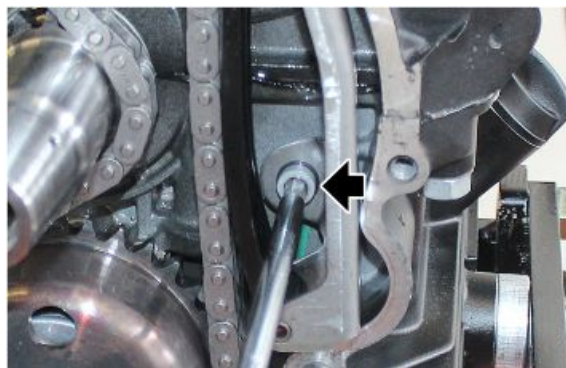

- Remove the chain tensioner



Chain removal

- Remove the timing system cover, the flywheel and the chain tensioner adjusting screw.
- Remove the bulkhead screw.

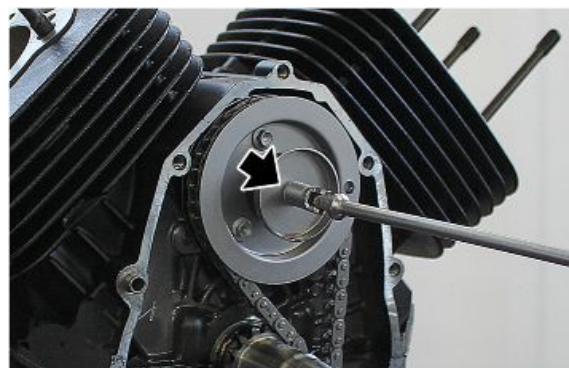

- Remove the 3 screws of the timing system sprocket and retrieve the front chain guide cap.

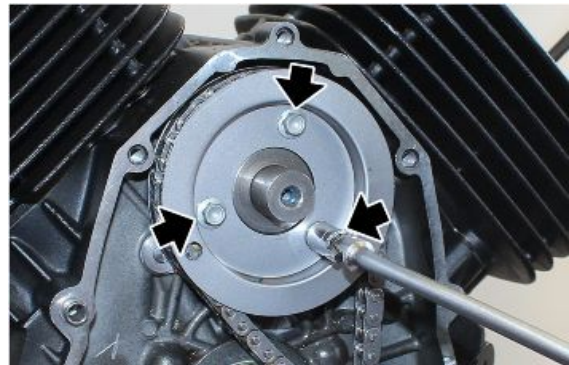

- Remove the fixing screw with relative washer for the oil pump gear.

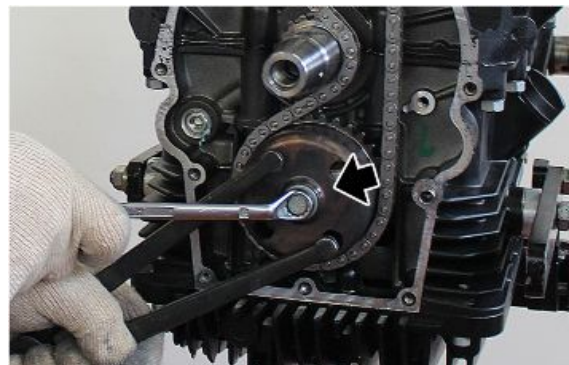

- Remove the timing chain, removing the camshaft gear and the oil pump gear at the same time

NOTE

PAY ATTENTION TO THE CENTRING PIN OF THE OIL PUMP GEAR.



- Retrieve the rear chain guide cap.



Removing the camshaft

- Remove the big ends and the cylinders.
- Remove the bucket tappets from the engine crankcase.



- Remove the timing system cover, the flywheel and the timing system chain.
- Remove the two fixing screws of the camshaft.

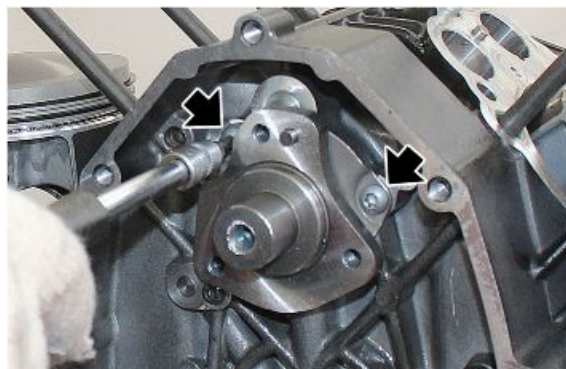

- Remove the camshaft extracting it from the crankcase and retrieve the fixing flange.



Installing the camshaft

- Insert the camshaft into the crankcase.
- Insert the flange in the specific slot.



- Place the two fixing screws and tighten them to the prescribed torque.



- Place the bucket tappets paying attention to the centring pin. Apply grease ensuring that it does not fall.



Installazione piattello blow-by

- Place the blow-by cap on the camshaft making the holes and the special timing plug match



Installazione catena

- For the installation of the timing chain, it is necessary to carry out the "Timing" procedure, therefore consult the specific chapter.

Cam timing

Timing

- Bring the piston of the left cylinder to top dead centre making sure that the reference mark on the crankshaft gear is up on the perpendicular axis and that the rocker have clearance



- After having placed the rear chain guide cap, fit the timing system chain, together with the timing system gear and the oil pump gear.



WARNING

PRIOR TO POSITIONING THE TIMING CHAIN WITH GEAR, ALIGN AS MUCH AS POSSIBLE THE MILLING PRESENT ON THE OIL PUMP PIN WITH THE GEAR OF THE PUMP ITSELF, TO ALLOW THE INSERTION OF THE SAFETY PLUG.

CAUTION

CHECK THE CORRECT INSTALLATION USING THE ALIGNMENT OF THE REFERENCE NOTCHES ON THE CRANKSHAFT AND ON THE TIMING SYSTEM GEAR

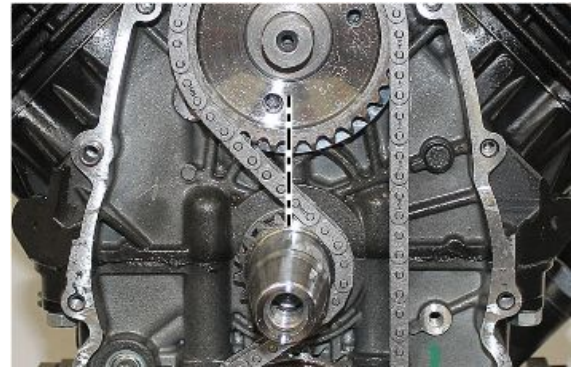

- Using a thin tool, refine the alignment of the oil pump pin with the milling on the gear of the pump itself.

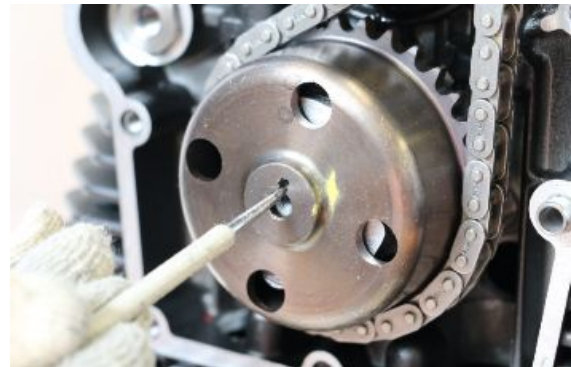

- Fit the safety plug.



- Fit the knurled washer and after placing the nut, tighten it to the prescribed torque

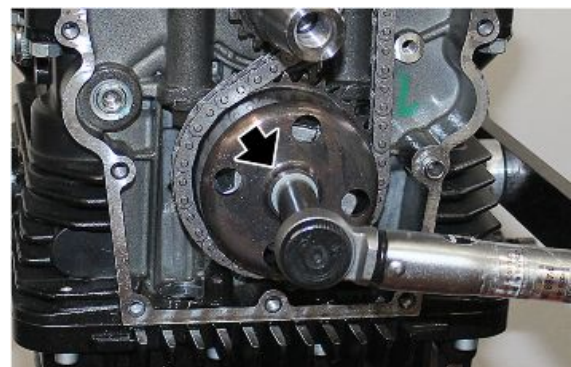

- Place the front chain guide on the timing system sprocket and then insert the three fixing screws and tighten them to the recommended torque.

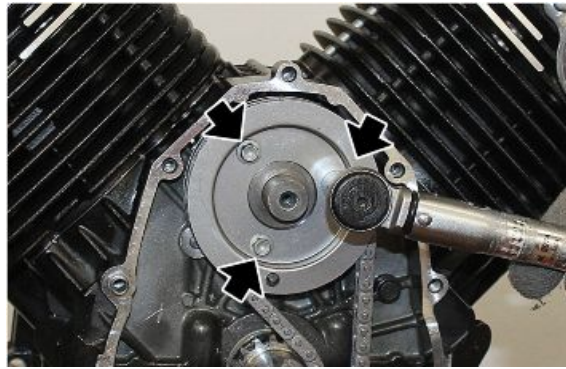

- Place the bulkhead on the camshaft, fit the fixing screw and tighten it to the recommended torque.

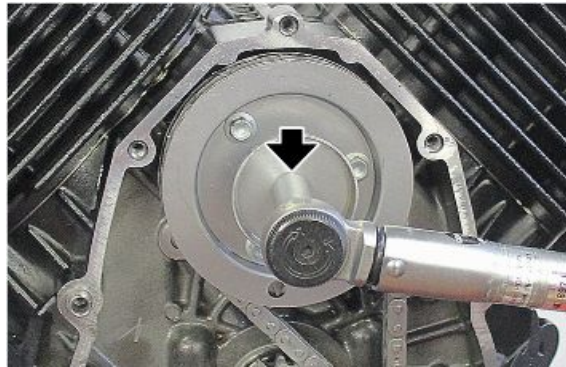

- Turn the crankshaft manually checking that there is no jamming. If jamming does occur, repeat the timing operation

Cylinder-piston assembly

Removing the cylinder

- Slide off the cylinder from the stud bolts.



- Remove the temperature sensor from the left cylinder.

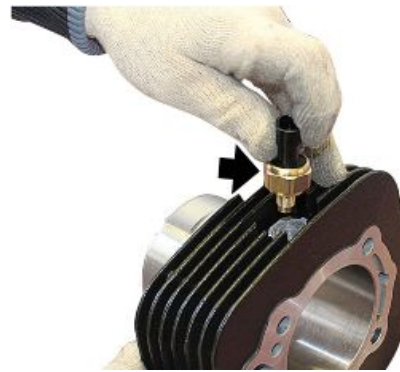

- Remove the gasket from the stud bolts

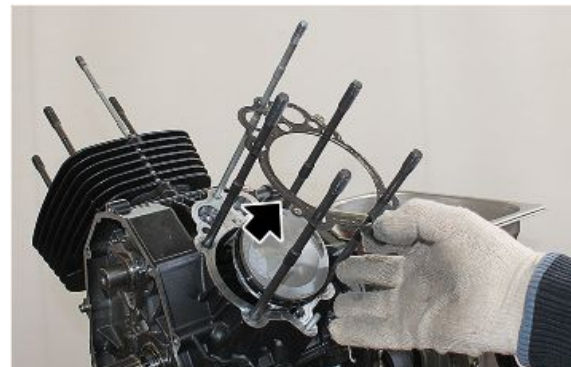

Disassembling the piston

- Remove one of the two retainer rings from the pin paying attention that it does not fall inside the engine



- Before removing the pin, check the mounting clearance between pin and piston. Replace it if the value is out of the limits
- Slide off the pin



Characteristic

Mounting clearance between piston and pin

0.01 mm (0.0004 in)

- Remove the piston

CAUTION

DURING SERVICING, CLEAN OFF ANY DEPOSITS FROM PISTON CROWN AND CIRCLIP GROOVES



Checking the cylinder

- After checking for scoring, check cylinder surface wear using a dial gauge graduated in hundredths of a millimetre.
- Measure the inner diameter of the cylinders at three different heights, turn the dial gauge (graduated in hundredths of a millimetre) 90° and repeat the measurements; set the dial gauge graduated in hundredths of a millimetre to zero using a ring gauge before measuring.

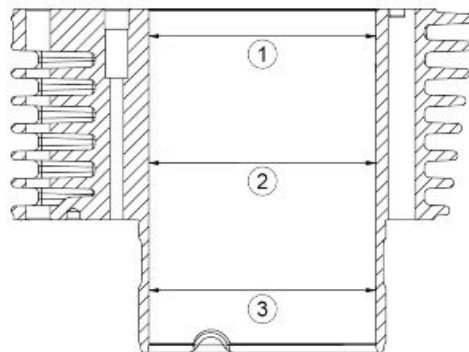

Key:

1. 1st measurement
2. 2nd measurement
3. 3rd measurement

CYLINDERS CONTROL

Type	Allowed diameter	Assembly clearance between piston and cylinder
G	84.000-84.007 mm (3.3071-3.3073 in)	0.040-0.054 mm (0.0016-0.0021 in)
H	84.007-84.014 mm (3.3074-3.3076 in)	0.040-0.054 mm (0.0016-0.0021 in)
L	84.014-84.021 mm (3.3076-3.3079 in)	0.040-0.054 mm (0.0016-0.0021 in)
M	84.021-84.028 mm (3.3079-3.3082 in)	0.040-0.054 mm (0.0016-0.0021 in)

Checking the piston

- Measure the piston skirt diameter (1) with a micrometer from the piston lower border (2)=10 mm (0.39 in).
- Replace the cylinder, the piston and the piston ring all together if not complying with specifications.

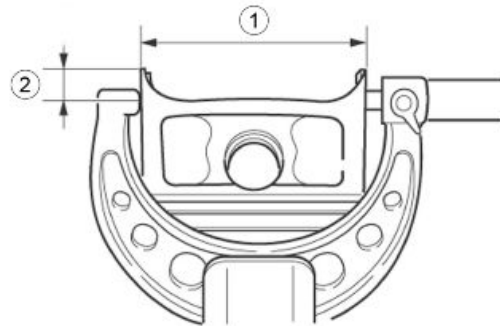

INSPECTING PISTONS

Type	Allowed diameter	Assembly clearance between piston and cylinder
G	83.953-83.960 mm (3.3052-3.3055 in)	0.040-0.054 mm (0.0016-0.0021 in)
H	83.960-83.967 mm (3.3055-3.3058 in)	0.040-0.054 mm (0.0016-0.0021 in)
L	83.967-83.974 mm (3.3058-3.3061 in)	0.040-0.054 mm (0.0016-0.0021 in)
M	83.974-83.981 mm (3.3061-3.3063 in)	0.040-0.054 mm (0.0016-0.0021 in)

Inspecting the wrist pin

PIN

- Clean off combustion residues from the piston crown and from the area above the top ring.
- Check for cracks on the piston and for compression on the piston sliding surface (seizing); Replace the piston if required.

- Measure the pin outside diameter (1) and if not complying with specifications; replace the pin.

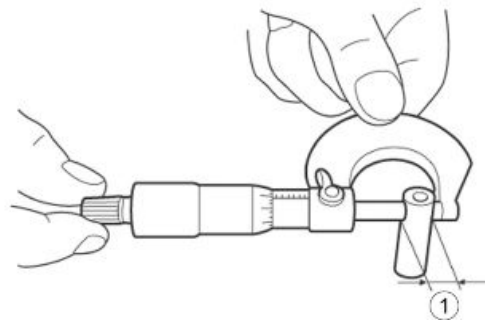

Characteristic

Pin external diameter (MINIMUM WEAR VALUE)

19.996 mm (0.7872 in)

Inspecting the piston rings

- Clean off any carbon deposits from the grooves in the piston rings and from the rings themselves.
- Measure the piston ring side clearance and replace the piston and the piston rings all together if not complying with specifications.

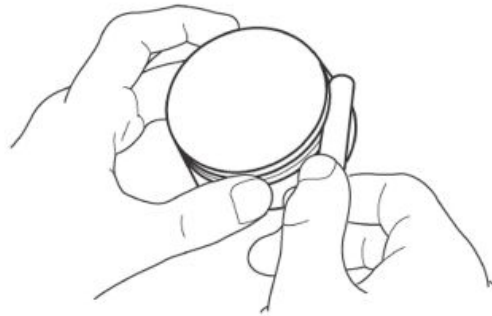

SEAL RING CLEARANCE (MAXIMUM WEAR VALUES)

Type	Maximum clearance between the rings and cables on the piston	Maximum opening of the rings mounted on the piston
Upper ring	0.07 mm (0.0028 in)	0.10-0.30 mm (0.0039-0.0118 in)
Intermediate ring	0.06 mm (0.0024 in)	0.35-0.55 mm (0.0138-0.0217 in)
Oil scraper ring	0.18 mm (0.0071 in)	0.20-0.70 mm (0.0079-0.0276 in)

- Fit the piston ring to the cylinder.
- Level the installed piston ring with the piston crown.
- Measure piston ring port and replace it if not complying with specifications.

CAUTION

IT IS NOT POSSIBLE TO MEASURE THE CLEARANCE OF THE END OF THE OIL SCRAPER RING: IF THERE IS EXCESSIVE PLAY, REPLACE THE THREE ELASTIC RINGS.

- Insert the piston rings paying attention to their mounting direction and end gap arrangement; the end gaps must be approximately 180 degrees from each other.

Fitting the piston

- Place the piston on the connecting rod notch

CAUTION

MOUNTING POSITION IS INDICATED BY AN ARROW POINTING IN THE DIRECTION OF TRAVEL



- Insert the pin



- Insert the retainer ring

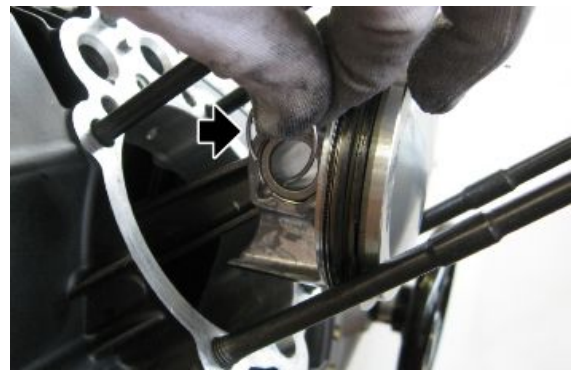

Installing the cylinder

- Check that the piston ring end gaps are approximately 120 degrees from each other.
- Fit a new gasket



- Place the appropriate ring clamp on the piston
- Place the cylinder so that the piston correctly enters the seat and as soon as the segments zone is exceeded remove the ring clamp

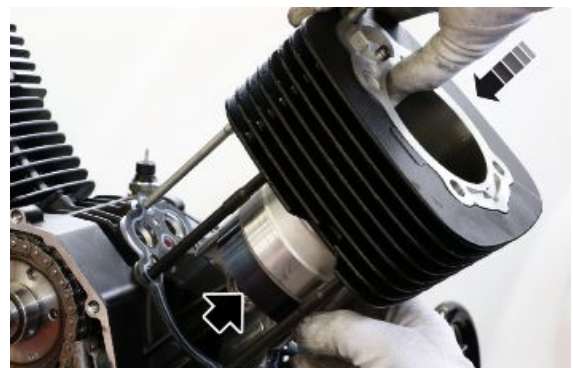

Specific tooling

020128Y Piston fitting ring

- Fit the temperature sensor existing only in the left cylinder.



- After fitting the cylinder it is necessary to check the piston projection for correct head gasket selection.
- Fit a dial gauge on the specific tool and set it to zero on a horizontal plane.



Specific tooling

020996Y Piston protrusion measurement tool

- Fit the tool together with the dial gauge on the cylinder and tighten the fixing nuts.
- Detect the deviation on the dial gauge



Specific tooling

020996Y Piston protrusion measurement tool

CAUTION

THE PISTON PROJECTION MUST BE DETECTED BY FITTING THE GASKET BETWEEN CRANK-CASE AND CYLINDER. BEFORE THE DETECTION TIGHTEN THE CYLINDER UNTIL THE GASKET IS COMPLETELY WOUND

HEAD GASKET SELECTION

Piston projection	Gasket thickness
0.40-0.58 mm (0.0157-0.0228 in)	0.6 +/- 0.05 mm (0.0236 +/- 0.0020 in)
0.20-0.40 mm (0.0079-0.0157 in)	0.8 +/- 0.05 mm (0.0315 +/- 0.0020 in)
0.02-0.20 mm (0.0008-0.0079 in)	1.0 +/- 0.05 mm (0.0394 +/- 0.0020 in)

- Place the cylinder.

Installing the cylinder head

- Insert the flame trap of the secondary air valve



- Insert the reed valve



- Fit the cover of the secondary air valve and tighten the screws to the prescribed torque



- Place the gasket



- Place engine head into place



- Place the three rubber O-Rings, particularly apply grease to the O-Ring that will be inserted in the stud bolt in order to avoid damaging it



- Position the cam tower in its seat



- Following a cross order "A-C-B-D" screw the fixing nuts of the cam tower to the prescribed torque

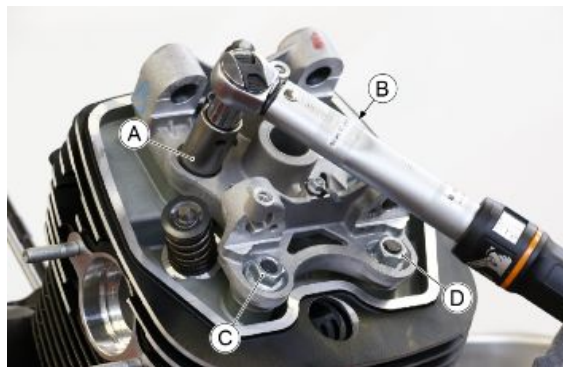

- Insert and tighten the compensation nut of the cam tower to the prescribed torque



- Position the washer with the relevant nut on the base of the cylinder and tighten to the prescribed torque.



- Insert the rocker rods

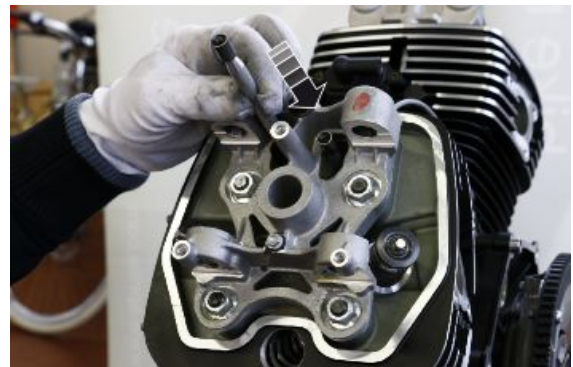

- Place the rocker in its seat by inserting the Belleville spring at the same time

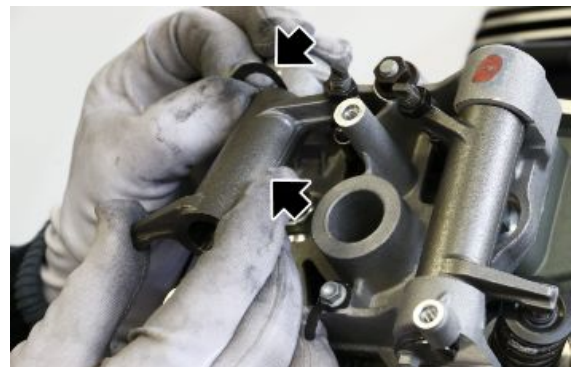

- Using the rocker shim centring pin, align the rocker and the Belleville spring with the pin seat for easy insertion

Specific tooling

020995Y Rocker arm centring pin

- Insert the rocker pin retainer fork on the pin and insert it in the seat

CAUTION

SLOWLY INSERT THE ROCKER PIN UNTIL THE FORK REACHES THE SUPPORT POINT ON THE CAM TOWER. THE INSERTION OF THE ROCKER PIN WITHOUT THE FORK REACHES A NON-CONTROLLED DEPTH

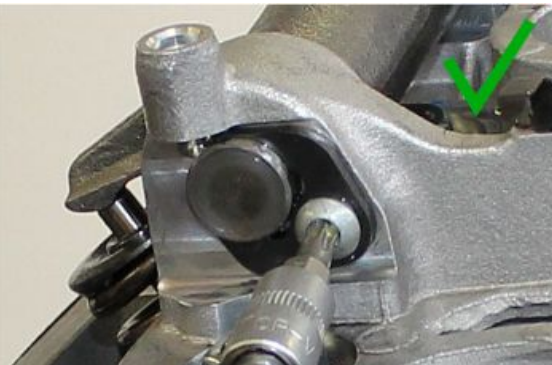

- Insert and tighten the fixing screw of the rocker pin lock fork to the prescribed torque

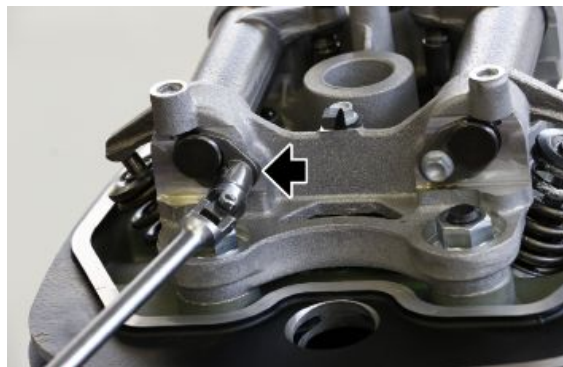

- Insert and tighten the spark plug to the prescribed torque



Installing the head cover

- Fit the gasket on the head cover



- Place the head cover together with the gaskets on the seats of the fixing screws



- Place the cover fixing screws and tighten them to the prescribed torque



Crankcase - crankshaft

Splitting the crankcase halves

- Remove the bucket tappets, the oil sump, the filter and the overpressure valve.
- Unscrew and remove the six external nuts and their washers.

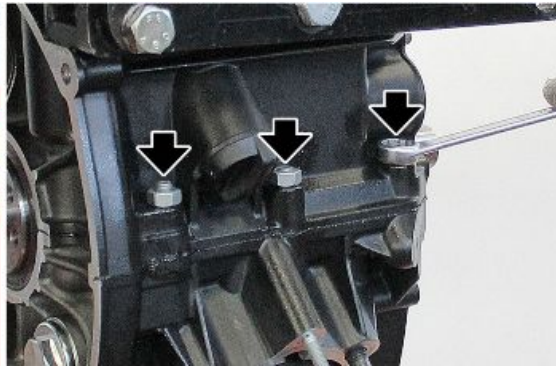
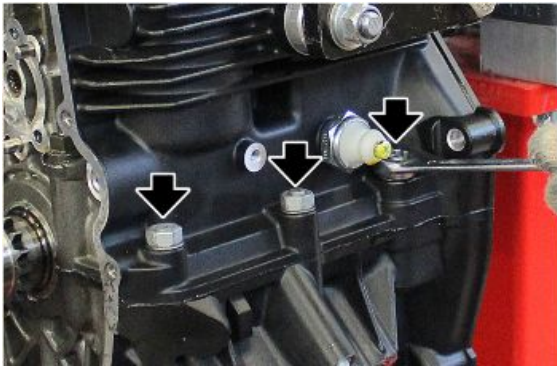

- Undo and remove the four long nuts from the inside of the crankcase.

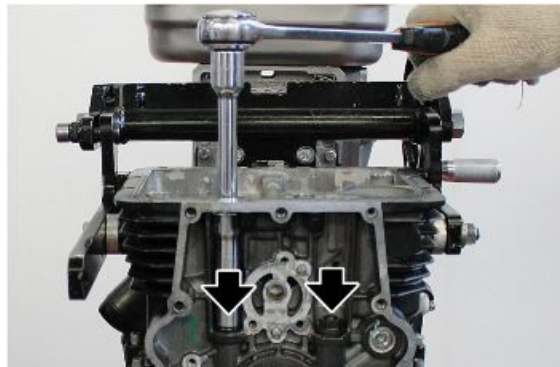

- Remove the upper crankcase being careful not to damage its mating face



- Retrieve the two half ring shims from the gearbox side.

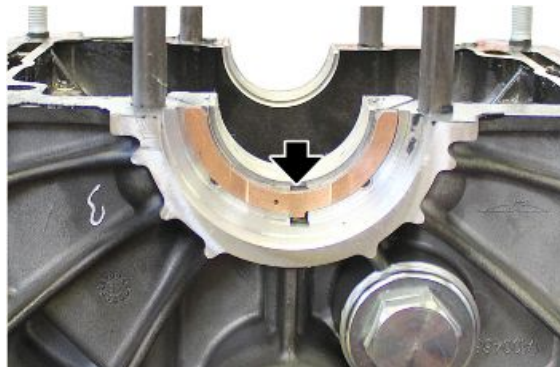

- Remove the crankshaft together with connecting rods and small ends



Removing the crankshaft

- Remove the crankshaft connecting rods.
- Unscrew the oil plug and thoroughly clean the oilway and oil passages delivering oil to connecting rods and main journals.

Inspecting the crankcase halves

- Check that the mating faces are not damaged, dented or scored. Remove the liquid gasket residues.
- Check that the threads of the stud bolts are not dented or stripped; if they are, replace the stud bolt or stud bolts.
- Blow all oil galleries of the two crankcase halves with compressed air.

Inspecting the crankshaft components

- Smear the thread of the cap with threadlocker and tighten the cap firmly.
- Blow with compressed air to clean the lubrication passage seats.

CAUTION

THE CRANKSHAFT IS NITRIDED AND CANNOT BE GROUND; IF WORN, TAPERED OR DEEPLY SCORED, THE CRANKSHAFT MUST BE REPLACED

CRANKSHAFT CHECK - LIMIT VALUES

Specification	Desc./Quantity
Main journal diameter on timing system side (WEAR LIMIT VALUE)	40.004 mm (1.5750 in)
Main bushing seat diameter on timing system side (MAXIMUM WEAR VALUE)	43.67 mm (1.7193 in)
Thickness for main bushing on timing system side (MAXIMUM WEAR VALUE)	1.805 mm (0.0711 in)
Main journal diameter on clutch side (MINIMUM WEAR VALUE)	43.007 mm (1.6932 in)
Main bushing seat diameter on clutch side (WEAR LIMIT VALUE)	47.142 mm (1.8560 in)
Total thickness for main bushing on clutch side (MINIMUM WEAR VALUE)	2.04 mm (0.0803 in)
Crankshaft thrust height (MAXIMUM WEAR VALUE)	24.81 mm (0.9768 in)
Crankcase thrust height (MINIMUM WEAR VALUE)	2.3 mm (0.0905 in)

Specification	Desc./Quantity
Thickness of the thrust half-bearings on main bushing on clutch side (MINIMUM WEAR VALUE)	2.31 mm (0.0909 in)
Diameter of crank pin (MINIMUM WEAR VALUE)	39.995 mm (1.5746 in)

The maximum parallelism deviation of the two crankshaft axes (connecting rod pin and main journals on flywheel side and timing system side) should not exceed 0.02 mm (0.0009 in) at 40 mm (1.5748 in) distance.

Installing the crankshaft

If it is necessary to replace the crankshaft or the connecting rods, follow the reference table regarding the couplings between the "CONNECTING ROD weight class mark" (1) and the "CRANK-SHAFT weight class mark" (2).

WARNING

MOUNT A PAIR OF CONNECTING RODS OF THE SAME CRANKSHAFT WEIGHT CLASS

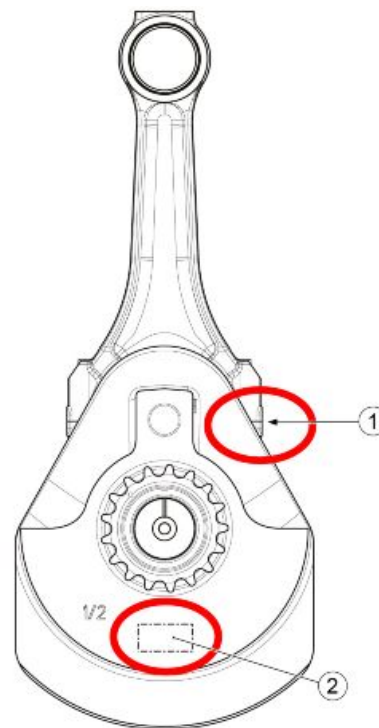

CONNECTING ROD/CRANKSHAFT WEIGHT CLASSES

CRANKSHAFT WEIGHT CLASS	CONNECTING ROD WEIGHT CLASS
E1	E1
E2	E2
E3	E3
E4	E4
E5	E5

Refitting the crankcase halves

- Insert the small ends timing system side and flywheel side on both crankcases paying attention to lubricate them

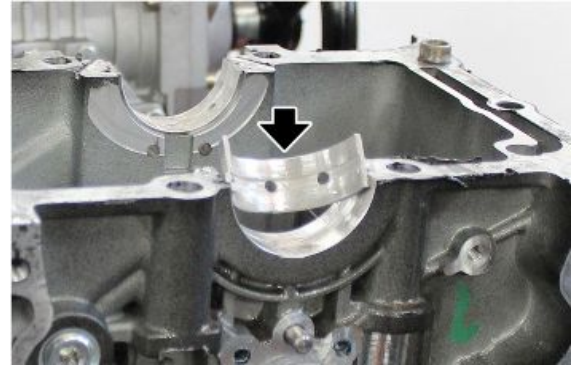

- With the help of grease, place the thrusts on the upper crankcase from the flywheel side, paying attention to lubricate them in the friction area

CAUTION

THE MOUNTING DIRECTION OF THE THRUSTS IS UNIQUE

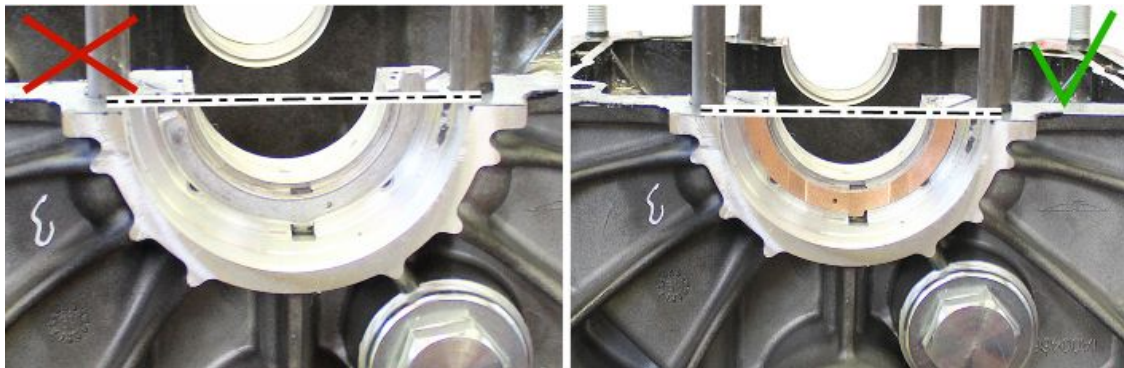

- Insert the seal ring (after lubricating it) on the crankshaft and the assembly onto the engine crankcase making sure that the connecting rods locate correctly into their seats.



- Smear the crankcases mating faces with the threebond

- Grasp the crankshaft assembly with the upper crankcase keeping the two components together, rotate them and lay them on the lower crankcase.



- Insert and screw the four long nuts and the six external nuts together with washers..
- Tighten all nuts to the prescribed torque proceeding with the cross order

Removing

- Remove the timing system complete with oil pump gear
- Using a hairdryer, heat the fixing base of the three oil pump screws.



- Remove the three fixing screws of the oil pump.

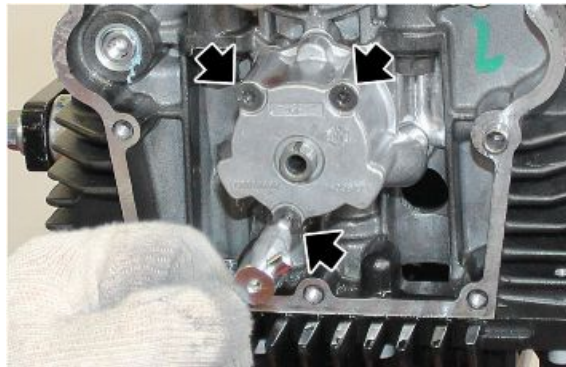

- Remove the complete pump from the crankcase.



- Remove the cover (1) from the pump (2).

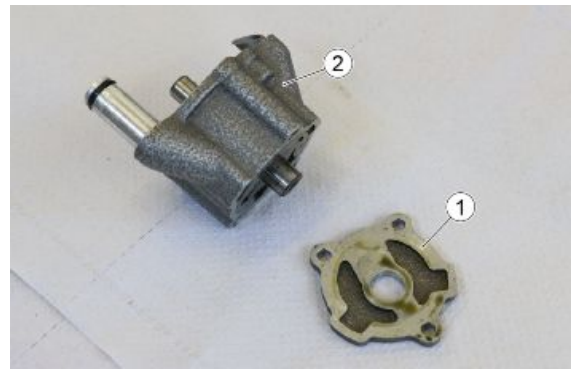

- Working on the oil pump gear side, remove the external rotor (3).



- Remove the internal rotor (4).

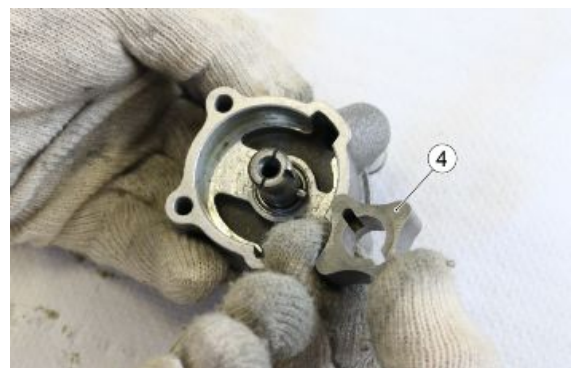

- Remove the safety pin (5) from the pump drive shaft.



- Working from the opposite side of the oil pump, extract the pump drive shaft (6) removing the internal rotor (7) and the external rotor (8).



Inspection

OIL PUMP BODY

Check that the faces and inner seats of the oil pump body are not scored, damaged or dented.

Pump body specifications:

OIL PUMP BODY

Description	Values
External rotors seat diameter (MAXIMUM WEAR VALUE)	40.675 mm (1.6014 in)
Diameter hole for pump drive shaft (MAXIMUM WEAR VALUE)	15.995 mm (0.6297 in)

EXTERNAL ROTORS

Check that the inner and outer surfaces and the flat faces are not scored, damaged or dented; if they are, replace both rotors of the side in question.

Data of the external rotors:

EXTERNAL ROTOR (ROTOR SIDE)

Description	Values
External diameter (WEAR LIMIT VALUE)	40.54 mm (1.5961 in)
Internal diameter (MAXIMUM WEAR VALUE)	24.23 mm (0.9539 in)
Thickness of seat (MAXIMUM WEAR VALUE)	12.07 mm (0.4752 in)

EXTERNAL ROTOR (CRANKCASE SIDE)

Description	Values
External diameter (WEAR LIMIT VALUE)	40.54 mm (1.5961 in)
Internal diameter (MAXIMUM WEAR VALUE)	24.23 mm (0.9539 in)
Thickness of seat (MAXIMUM WEAR VALUE)	14.07 mm (0.5539 in)

INTERNAL ROTOR

Check that the inner and outer surfaces and the flat faces are not scored, damaged or dented; if they are, replace both rotors of the side in question.

Data of the internal rotors:

INTERNAL ROTOR (ROTOR SIDE)

Description	Values
External diameter (MAXIMUM WEAR VALUE)	29.749 mm (0.1712 in)
Internal diameter (MAXIMUM WEAR VALUE)	12.018 mm (0.4731 in)
Thickness (MINIMUM WEAR VALUE)	11.97 mm (0.4713 in)

INTERNAL ROTOR (CRANKCASE SIDE)

Description	Values
External diameter (MAXIMUM WEAR VALUE)	29.749 mm (0.1712 in)
Internal diameter (MAXIMUM WEAR VALUE)	12.018 mm (0.4731 in)
Thickness (MINIMUM WEAR VALUE)	13.97 mm (0.5500 in)

OIL PUMP DRIVE SHAFT

Check shaft and thread for damage; check the keyway for burrs and make sure the head the runs in the rotor is not damaged; replace the shaft if needed.

Shaft specifications:

OIL PUMP DRIVE SHAFT

Description	Values
Diameter for pump body seat (MINIMUM WEAR VALUE)	11.989 mm (0.4720 in)
Diameter seat for roller bearings (MINIMUM WEAR VALUE)	9.991 mm (0.3933 in)

Installing

- Working from the rear side of the oil pump, insert the pump drive shaft (1) the internal rotor (2) and the external rotor (3).



- Working from the front of the oil pump, insert the internal rotor retaining pin (4).



- Insert the internal rotor (5) paying attention that the pin enters the machining seat.



- Insert the external rotor (6) paying attention to the punch mark that must be facing outwards.



- After inserting the cover, position the complete oil pump in place.



- Insert the three oil pump retaining screws and tighten them to the pre-defined tightening torque.

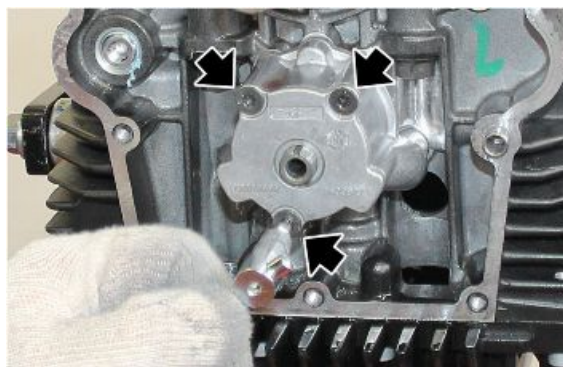

Oil sump

Removing the oil sump

- Remove the engine oil filter fixing screw



- Remove the engine oil filter



- -Remove the 14 fastening screws of the oil sump



- Remove the oil sump



- Remove the gasket



- Remove the rose pipe



- Remove the cap and the relative copper gasket

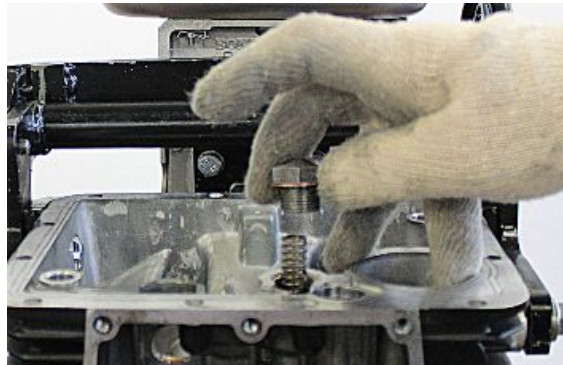

- Remove the spring

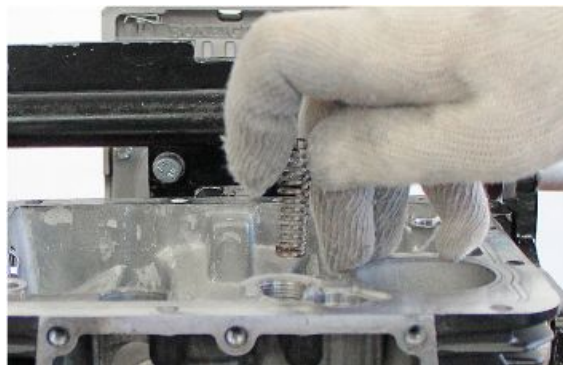

- Remove the overpressure valve



Refitting the oil sump

- Install the overpressure valve in the engine crankcase



- Insert the spring and afterwards the cap provided with a new copper gasket, tighten it to the prescribed torque

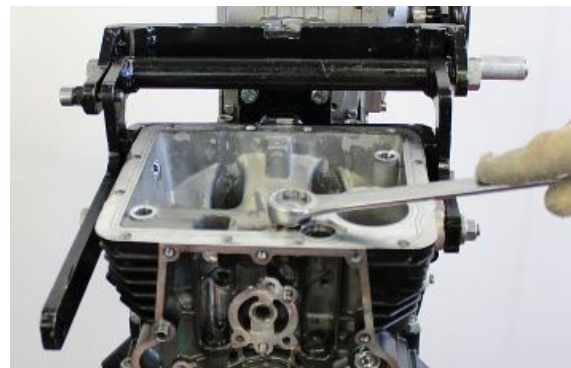

- Insert the rose pipe



- Place the gasket and insert the oil sump cover



- Insert and tighten the 14 fastening screws of the oil sump to the prescribed torque



- Insert the engine oil filter together with the cover



- Insert and tighten the locking screw of the engine oil filter to the prescribed torque



C

Chain: 64, 65

Chain tensioner: 64

Clutch: 37, 46, 47, 49, 50

Crankcase: 81, 83, 85

Crankshaft: 81, 83, 84

Cylinder: 56, 60, 70, 72, 75, 77

D

Desmodromic drum: 39

F

Forks: 39

H

Head cover: 55, 81

M

Magneto flywheel:

O

Oil sump: 90, 91, 93

P

Pistons:

Primary shaft: 27

S

Secondary air system:

Secondary shaft: 31

Start-up:

Starter motor: 46

T

Throttle body: