



MOTO GUZZI®

PROUDLY AUTHENTIC MOTORCYCLES. SINCE 1921.

MANUALE STAZIONE DI SERVIZIO

2Q000383

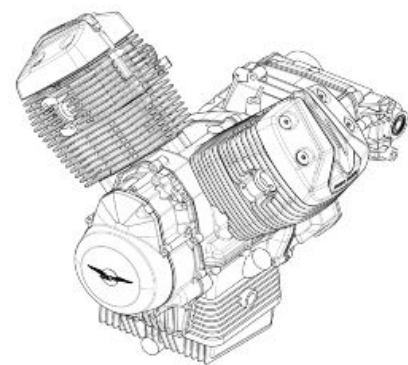

Engine V85 E4



MANUALE STAZIONE DI SERVIZIO

Engine V85 E4

THE VALUE OF SERVICE

As a result of continuous updates and specific technical training programmes for Moto Guzzi products, only **Moto Guzzi** Official Network mechanics know this vehicle fully and have the specific tools necessary to carry out maintenance and repair operations correctly.

The reliability of the vehicle also depends on its mechanical conditions. Checking the vehicle before riding it, its regular maintenance and the use of **original Moto Guzzi spare parts** only are essential factors!

For information on the nearest **Official Dealer and/or Service Centre** consult our website:

www.motoguzzi.com

Only by requesting Moto Guzzi original spare parts can you be sure of purchasing products that were developed and tested during the actual vehicle design stage. All Moto Guzzi original spare parts undergo quality control procedures to guarantee reliability and durability.

The descriptions and images in this publication are given for illustrative purposes only and are not binding. While the basic characteristics as described and illustrated in this booklet remain unchanged, Piaggio & C. S.p.A. reserves the right, at any time and without being required to update this publication beforehand, to make any changes to components, parts or accessories, which it considers necessary to improve the product or which are required for manufacturing or construction reasons.

Not all versions/models shown in this publication are available in all countries. The availability of individual versions should be checked with the Official Moto Guzzi sales network.

The Moto Guzzi brand is owned by Piaggio & C. S.p.A.

© Copyright 2019 - Piaggio & C. S.p.A. All rights reserved. Reproduction of this publication in whole or in part is prohibited.

Piaggio & C. S.p.A. Viale Rinaldo Piaggio, 25 - 56025 PONTEDERA (PI), Italy

www.piaggio.com

MANUALE STAZIONE DI SERVIZIO

Engine V85 E4

Questo manuale fornisce le informazioni principali per le procedure di normale intervento sul veicolo. Questa pubblicazione è indirizzata ai **Concessionari Moto Guzzi** e ai loro meccanici qualificati; molte nozioni sono state volutamente omesse, perché giudicate superflue. Non essendo possibile includere nozioni meccaniche complete in questa pubblicazione, le persone che utilizzano questo manuale devono essere in possesso sia di una preparazione meccanica di base, che di una conoscenza minima sulle procedure inerenti ai sistemi di riparazione dei motoveicoli. Senza queste conoscenze, la riparazione o il controllo del veicolo potrebbe essere inefficiente o pericolosa. Non essendo descritte dettagliatamente tutte le procedure per la riparazione, e il controllo del veicolo, bisogna adottare particolare attenzione al fine di evitare danni ai componenti e alle persone. Per offrire al cliente maggiore soddisfazione dall'uso del veicolo, **Moto Guzzi** s.p.a. si impegna a migliorare continuamente i propri prodotti e la relativa documentazione. Le principali modifiche tecniche e modifiche alle procedure per le riparazioni del veicolo vengono comunicate a tutti i **Punti Vendita Moto Guzzi e alle Filiali nel Mondo**. Tali modifiche verranno apportate, nelle edizioni successive di questo manuale. Nel caso di necessità o dubbi sulle procedure di riparazione e di controllo, interpellare il **REPARTO ASSISTENZA Moto Guzzi**, il quale sarà in grado di fornirvi qualsiasi informazione al riguardo, oltre a fornire eventuali comunicazioni su aggiornamenti e modifiche tecniche applicate al veicolo.

NOTE Provides key information to make the procedure easier to understand and carry out.

CAUTION Refers to specific procedures to carry out for preventing damages to the vehicle.

WARNING Refers to specific procedures to carry out to prevent injuries to the repairer.



Personal safety Failure to completely observe these instructions will result in serious risk of personal injury.



Safeguarding the environment Sections marked with this symbol indicate the correct use of the vehicle to prevent damaging the environment.



Vehicle intactness The incomplete or non-observance of these regulations leads to the risk of serious damage to the vehicle and sometimes even the invalidity of the guarantee

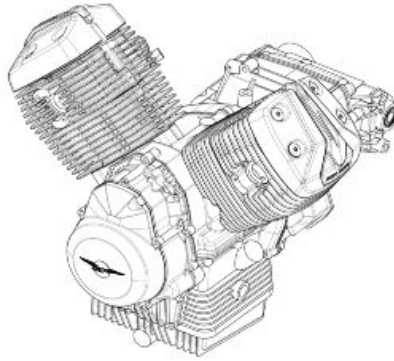

INDEX OF TOPICS

CHARACTERISTICS

CHAR

SPECIAL TOOLS

S-TOOLS

ENGINE

ENG

INDEX OF TOPICS

CHARACTERISTICS

CHAR

Tightening Torques

If the following tables do not expressly indicate the tightening torque values, refer to the table with the generic torque values indicated below.

GENERAL TIGHTENING TORQUES

| | M4 | M5 | M6 | M8 | M10 | M12 |
|--|----------------------|----------------------|-----------------------|------------------------|------------------------|------------------------|
| Metric tightening torque: TE - TEFL - SHC - TBEI - TCC - TS | 3 Nm (2.21 lb ft) | 6 Nm (4.43 lb ft) | 10 Nm (7.38 lb ft) | 25 Nm (18.44 lb ft) | 50 Nm (36.88 lb ft) | 80 Nm (59.00 lb ft) |

GENERAL TIGHTENING TORQUES FOR SELF TAPPING SCREWS FOR PLASTIC

| | 2.9 mm | 3.9 mm | 4.2 mm | 5 mm |
|-------------------|-------------------|-------------------|-------------------|-------------------|
| Tightening torque | 2 Nm (1.48 lb ft) | 2 Nm (1.48 lb ft) | 3 Nm (2.21 lb ft) | 3 Nm (2.21 lb ft) |

CAUTION





THE SCREWS WITH THREAD-LOCK SEALANT (PRE-IMPREGNATED) MUST BE REPLACED WITH NEW SCREWS AFTER THEY HAVE BEEN LOOSENED. BEFORE FITTING THE NEW SCREWS, CLEAN THE THREADED HOLES CAREFULLY, MAKING SURE THAT ALL TRACES OF THE OLD THREAD-LOCK SEALANT HAVE BEEN ELIMINATED.

INDEX OF TOPICS

SSPECIAL TOOLS

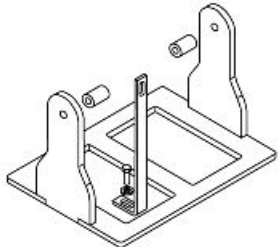
S-TOOLS

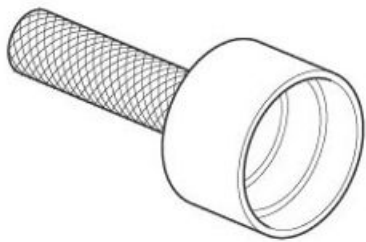
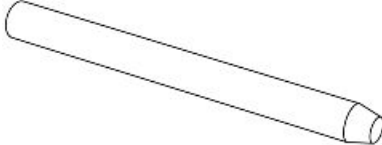
SPECIAL TOOLS

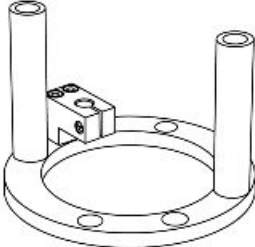
| Stores code | Description | |
|-------------|--|---|
| 020997Y | Engine mounting plate |  |
| 020382Y | Tool to extract valve cotters |  |
| GU19927100 | Tool for mounting seal ring on flange on the flywheel side |  |
| 020995Y | Rocker arm centring pin |  |
| 020128Y | Piston ring compressor |  |
| 020996Y | Piston protrusion measuring tool |  |

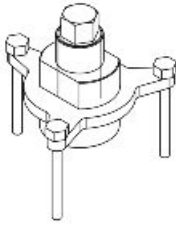
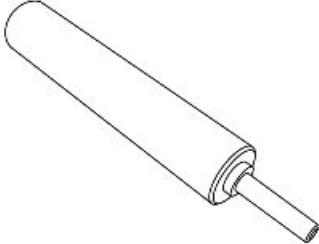
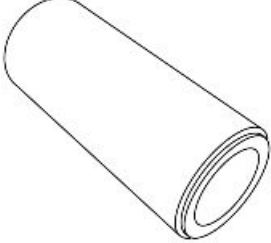
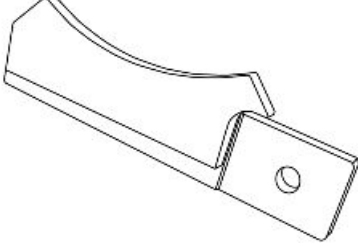
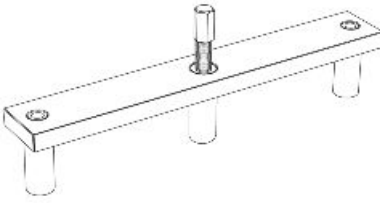
| Stores code | Description | |
|-------------|--|--|
| 020713Y | Flywheel extractor |  |
| 020976Y | Clutch control dust guard mounting punch |  |
| 021020Y | Clutch housing oil seal mounting punch |  |
| 021001Y | Clutch lock |  |
| 021002Y | Clutch centring |  |

INDEX OF TOPICS

ENGINE

ENG

Gearbox

Diagram

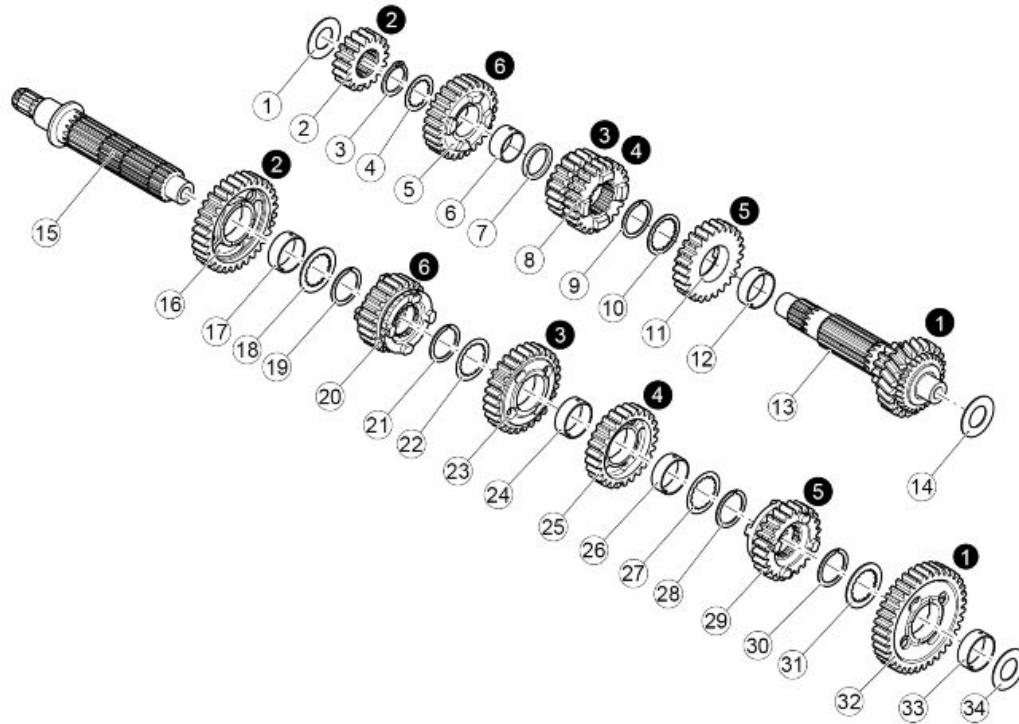

key:

- 1. Thrust washer
- 2. 2nd speed gear on main shaft
- 3. Circlip
- 4. Thrust washer
- 5. 6th speed gear on main shaft
- 6. Floating bushing
- 7. Main shaft thrust washer
- 8. 3rd and 4th speed sliding gear on main shaft
- 9. Circlip for the shaft
- 10. Thrust washer
- 11. 5th speed gear on main shaft
- 12. Floating bushing
- 13. Main shaft with PI
- 14. Thrust washer
- 15. Transmission shaft
- 16. 2nd speed gear on transmission shaft

-
- 17. Floating bushing
 - 18. Thrust washer
 - 19. Circlip for the shaft
 - 20. 6th speed gear on transmission shaft
 - 21. Circlip for the shaft
 - 22. Thrust washer
 - 23. 3rd speed gear on transmission shaft
 - 24. Floating bushing
 - 25. 4th speed gear on transmission shaft
 - 26. Floating bushing
 - 27. Thrust washer
 - 28. Circlip for the shaft
 - 29. 5th speed gear on transmission shaft
 - 30. Circlip for the shaft
 - 31. Thrust washer
 - 32. 1st speed gear on transmission shaft
 - 33. Floating bushing
 - 34. Thrust washer

Gearbox

Removing the gearbox

- Remove the 5 screws (1) fixing the gearbox to the engine crankcase



- Remove the fixing screw (2) of the gearbox, placed from the engine crankcase side



- Remove the complete gearbox screw



Gearbox shafts

Disassembling the gearbox

- Remove the 12 fixing screws of the gearbox, engine side.

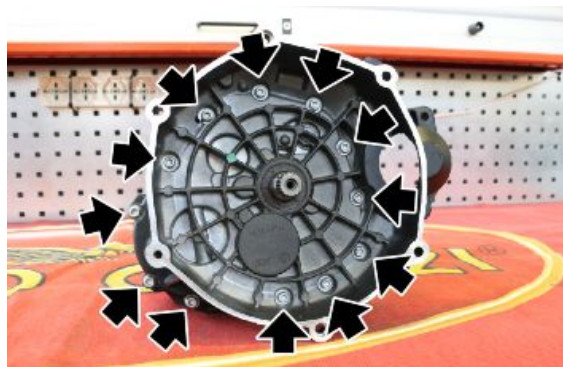

- Remove the fastening screw of the gearbox, cardan side.



- Remove the external body (1), the thrust bearing (2) and two related sliding washers (3) and the external body (4).

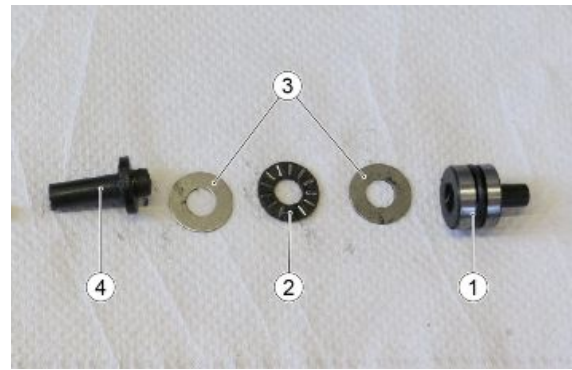

- Remove the pusher plate



- Remove the gearbox cover with a few mallet strokes



- Having removed all internal components, to remove the bearings fitted in the gearbox crank-cases, the safety washers/plate must be removed first.

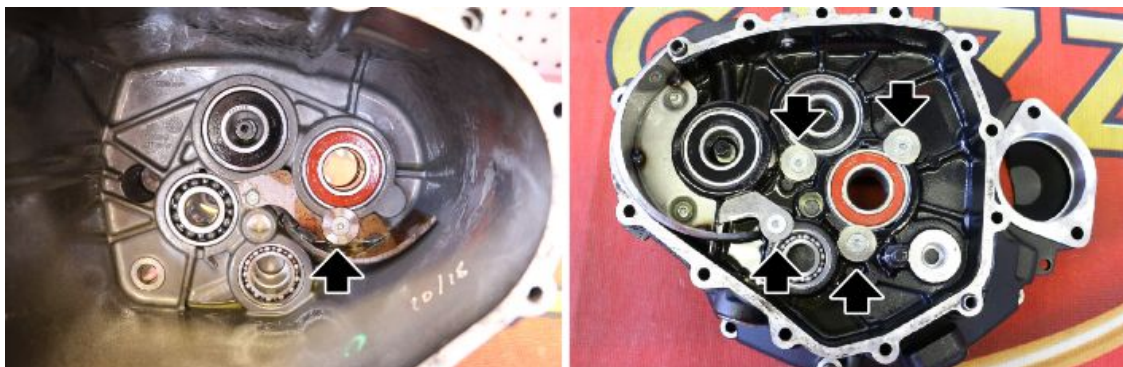

- The bearings from the gearbox crankcases can be removed using generic extractors.



- Heat the primary shaft bearing area on the base of the gearbox crankcase and the secondary shaft area on the gearbox crankcase cover very well with a hair dryer. It will then be possible to remove the bearings by knocking the crankcasings on a surface. If necessary, use a dummy ball bearing extractor.



- If necessary, remove the screws securing the bulkheads located in the crankcase to be able to extract them.



Removing the primary shaft

CAUTION

FIT NEW CIRCLIPS WHEN REASSEMBLING

- Remove the gear selector shaft, the desmodromic shaft and the forks with shaft
- Remove the complete gear unit



To dismantle the main shaft, proceed as follows:

- Remove the shim washer (1)



- Remove the gear of the 2nd gear (2)



- Using the appropriate jaws, lock the primary shaft in a vice and remove the circlip (3)



- Remove the spacer (4)

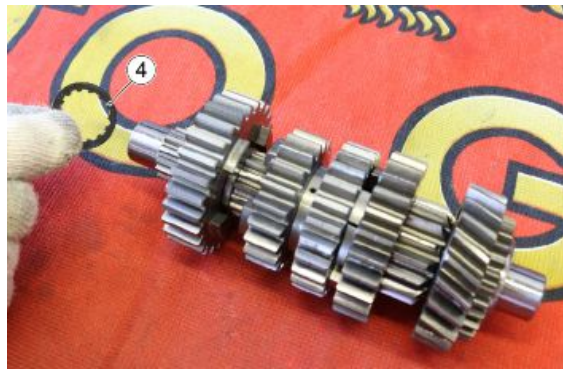

- Remove the gear of the 6th gear (5)



- Remove the bushing (6)

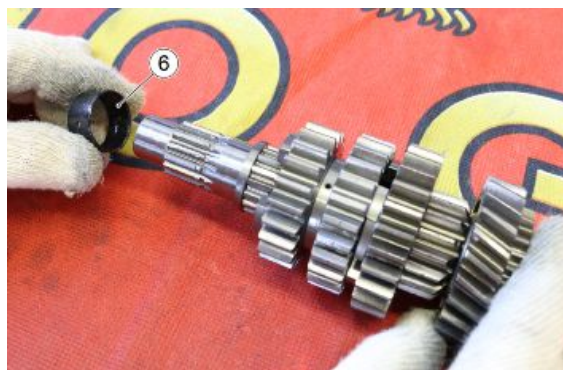

- Remove the spacer (7)



- Remove the gear of the 3-4th gear (8)

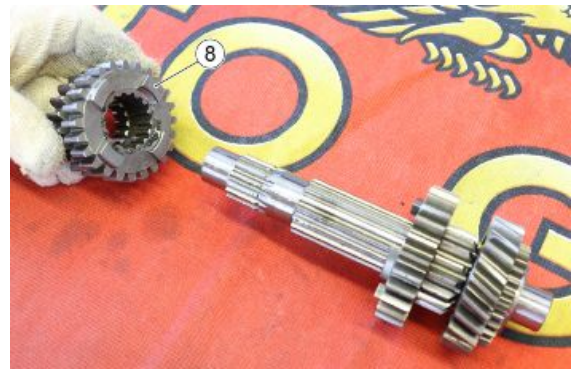

- Using the appropriate jaws, lock the primary shaft in a vice and remove the circlip (9)



- Remove the spacer (10)

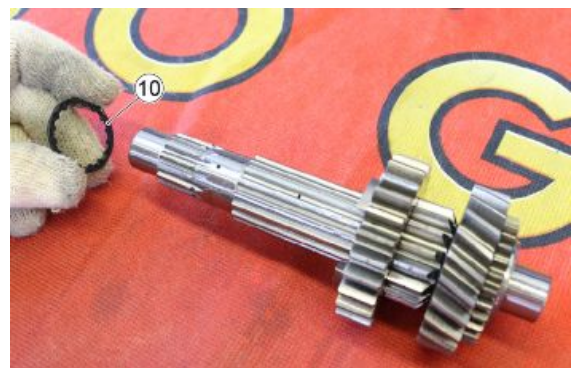

- Remove the gear of the 5th gear (11)



- Remove the bushing (12)



- Remove the washer (13) from the main shaft (14)



Removing the secondary shaft

CAUTION

FIT NEW CIRCLIPS WHEN REASSEMBLING

Disassemble the secondary shaft as follows:

- Remove the shim washer (1)



- Remove the gear of the first gear (2)

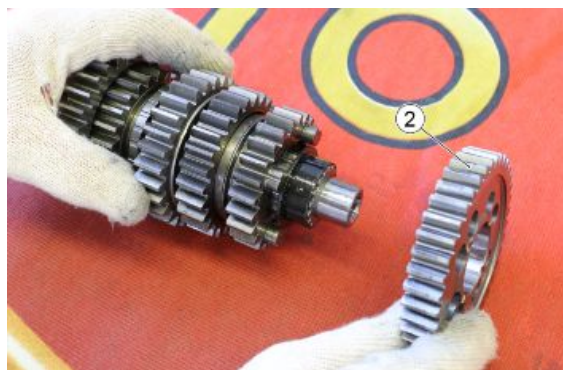

- Remove the bushing (3)



- Remove the shim washer (4)



- Remove the seeger ring (5)



- Remove the gear of the 5th gear (6)



- Remove the seeger ring (7)



- Remove the shim washer (8)



- Remove the gear of the 4th gear (9)



- Remove the bushing (10)



- Remove the gear of the 3rd gear (11)



- Remove the bushing (12)

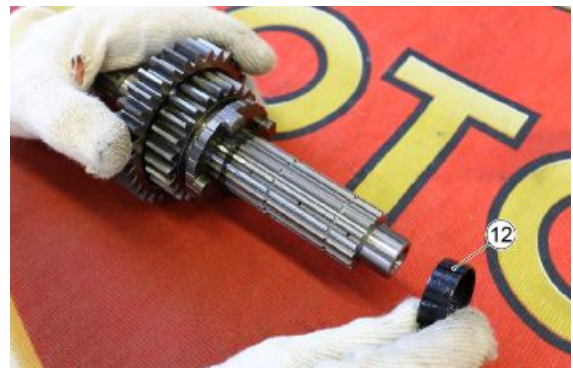

- Remove the shim washer (13)



- Remove the seeger ring (14)



- Remove the gear of the 6th gear (15)



- Remove the seeger ring (16)

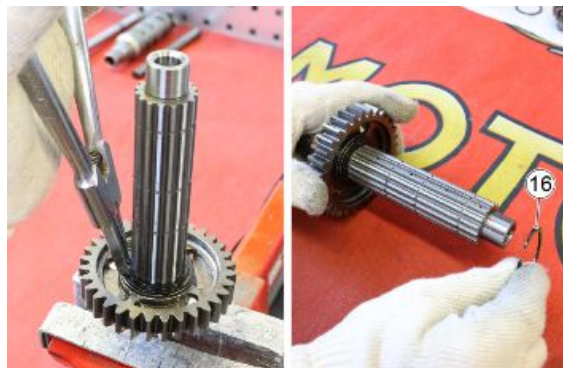

- Remove the shim washer (17)



- Remove the gear of the 2nd gear (18)



- Remove the bushing (19)



Desmodromic demounting

- Remove the fork carrier shaft (1).



- Remove the desmodromic shaft (2).



- The forks are marked with a serial number that indicated the correct positioning.
- Remove the upper fork No.1 (3)



- Remove the lower fork No.3 (4)



- Remove the primary and secondary shaft, as well as the intermediate fork No. 2



Disassembling the clutch shaft

- To remove the clutch shaft it is necessary to remove first all gearbox components (the input shaft, the secondary shaft, fork travel shaft and the forks, gearbox selector).
- At this point, the clutch shaft can be removed with a few mallet taps, paying attention to retrieve the shimming washer.
- Remove the oil seal from the clutch shaft



WARNING

IN CASE OF OIL SEAL REPLACEMENT, WHEN REFITTING USE THE SUITABLE PUNCH UNTIL IT REACHES THE END

Specific tooling

020976Y Clutch control dust guard mounting punch



- Remove the oil seal

CAUTION

IN CASE OF OIL SEAL REPLACEMENT, USE THE SUITABLE PUNCH UNTIL IT REACHES THE CRANKCASE

Specific tooling

021020Y Clutch housing oil seal mounting punch



Controllo alberi

Check transmission gears for signs of pitting and wear and replace damaged gears if necessary.
 Check the gear fitting teeth for cracks, damage and wear and replace those damaged if necessary.
 Check the transmission gears movement and, if it is not regular, replace the damaged part.

WEAR LIMITS

| Specification | Desc./Quantity |
|---|---|
| Maximum wear limit for the selection gear grooves | 22.78 mm (0.896 in) with rollers diam. 3.5 mm (0.14 in) |
| Minimum wear limit of the cardan shaft side secondary shaft seats | 23.294 mm (0.9171 in) with rollers diam. 3.0 mm (0.12 in) |
| Minimum wear limit of the clutch side primary and secondary shaft seats | 24.112 mm (0.9493 in) with rollers diam. 2.0 mm (0.08 in) |

Checking the clutch shaft

Check for pitting, wear, cracks or damage, signs of deterioration on the teeth of the primary drive gear and replace the gear if necessary



WEAR LIMITS

| Specification | Desc./Quantity |
|---|-----------------------|
| (1) Minimum wear limit of the rotation point on the gearbox cover bearing | 19.975 mm (0.7864 in) |
| (2) Minimum wear limit of the rotation point on the gearbox cover base | 24.987 mm (0.9837 in) |

Checking the desmodromic drum

Check the desmodromic drum for damage, scratches and wear and replace the assembly if required.

Checking the forks

Check that the forks have the work surface well smooth and not worn, so to lose its quenching characteristics and that the nibs that are working in the drum grooves are not too worn, otherwise replace the forks.

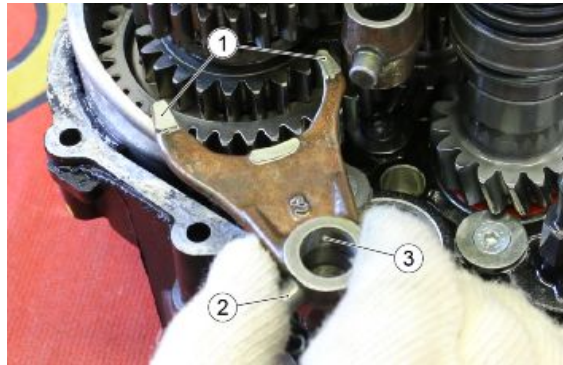

WEAR LIMITS

| Specification | Desc./Quantity |
|------------------------------------|-------------------|
| (1) Minimum thickness of the tines | 4.75 mm (0.19 in) |
| (2) Guide pins minimum diameter | 8 mm (0.31 in) |
| (3) Sliding hole minimum diameter | 14 mm (0.55 in) |

Assembling the gearbox

- In case of secondary oil seal replacement of the cardan on the gearbox cover, use the special punch until it stops.

Specific tooling

020978Y Cardan secondary oil seal mounting punch



- Use commercial punches to insert the bearings on the gearbox crankcases.

- A special punch must be used to insert the bearings on the seats of the primary/secondary shaft with lubrication duct.

Specific tooling

GU19926500 Punch for transmission case bearing external ring



- After installing the bearings on the gearbox crankcasings, position the bulkheads and the safety washers/plates, and tightening them with the appropriate screws to the prescribed torque.

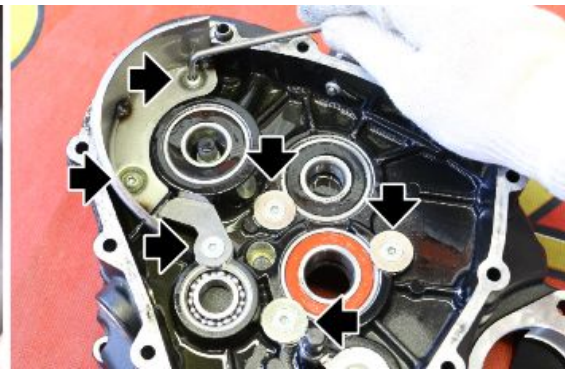
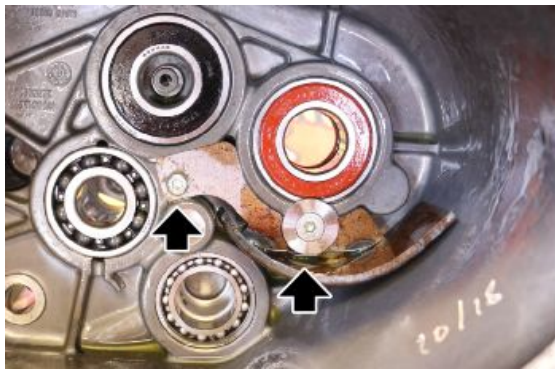

- After inserting all the internal components, apply a layer of threebond on the junction surface of the two crank-casings.



- Position the gearbox cover and manually tighten the gearbox fixing screw on the cardan side.



- Insert the 12 fixing screws of the gearbox, engine side and then tighten them to the prescribed torque, including the screw opposite the cardan side previously tightened manually.

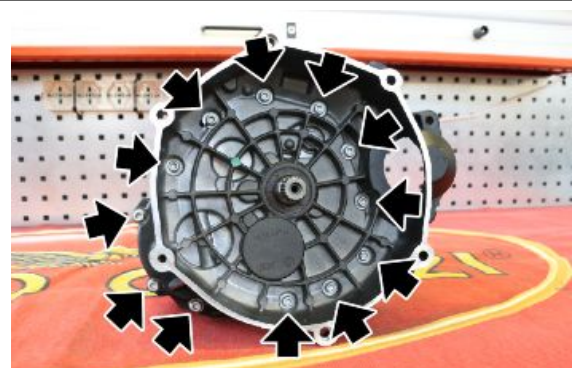

- After inserting the two half-cones (1) on the thrust plate (2), insert it on the clutch shaft working from the cardan side and paying attention to the orientation, as the machining must push on the cap once the reassembling of the gearbox on the engine is complete.

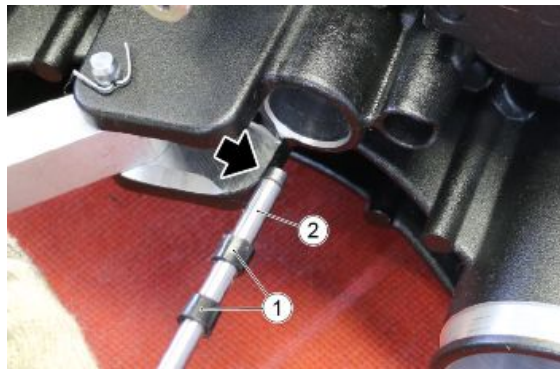

- Insert the intermediate body (3), the thrust bearing (4) and two related sliding washers (5) and the external body (6).

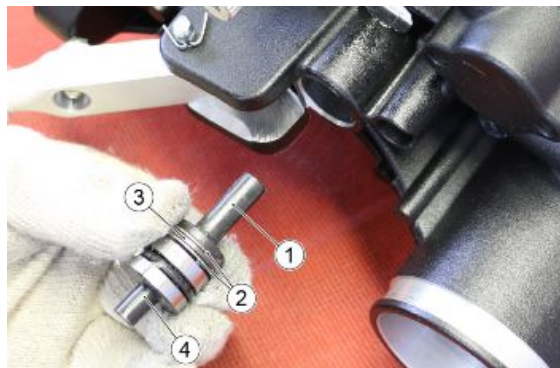

Gear selector

Removing the gear selector

- Remove the desmodromic shaft first and then the complete gear selector shaft (1).



- Remove the spring from the index lever (2)



- Remove the washer (3)



- Remove the seeger ring (4)



- Remove the seeger ring (5)



- Remove the washer (6)

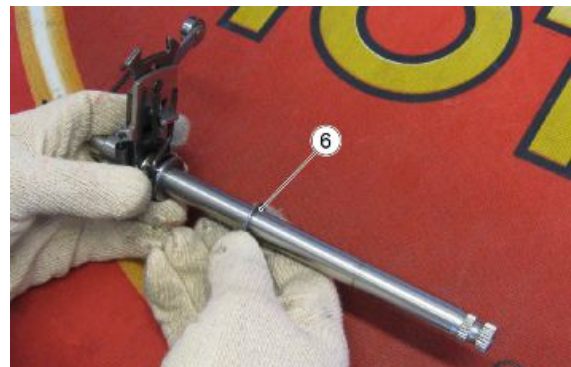

- Remove the bushing (7)

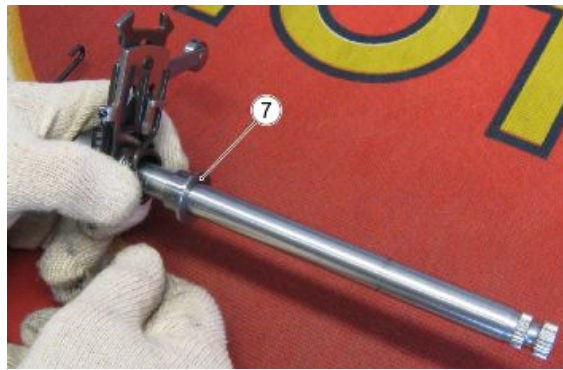

- Remove the selector spring (8)

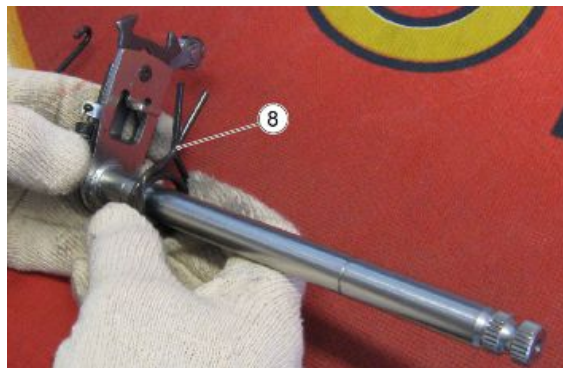

- Remove the ring (9)



- Remove the bushing (10)

WARNING

DURING REFITTING, PAY ATTENTION TO THE CORRECT POSITIONING OF THE BUSHING, AS THE SIDES ARE NOT SYMMETRICAL



- Remove the index lever (11)

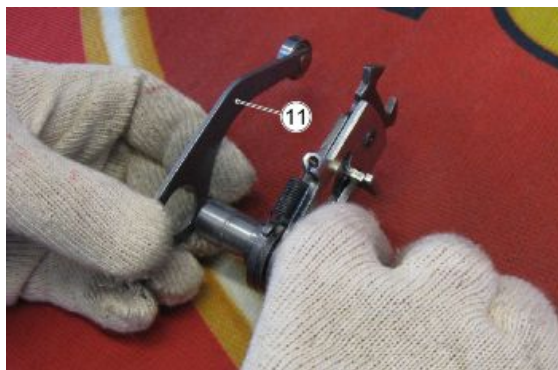

- Remove the selector return spring (13)

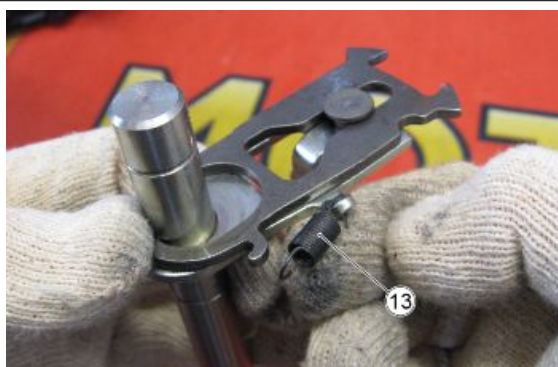

Generatore

Rimozione sensore giri

- Undo and remove the fixing screw of the sensor



- Remove the timing system cover sensor



Generator removal

ALTERNATOR COVER REMOVAL

- Remove the alternator cover fixing screws

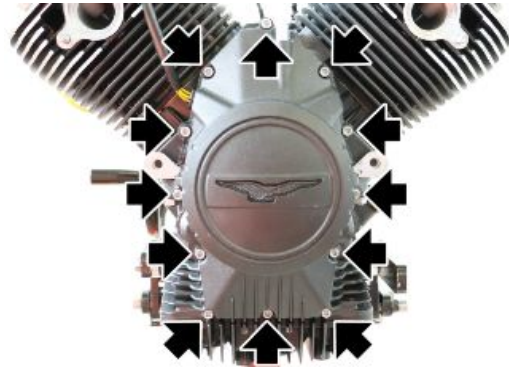

- Remove the alternator cover.



- Remove the gasket.



ROTOR REMOVAL

- From the clutch side, partially unscrew the two fixing screws of the clutch plate, as indicated, to allow the correct positioning of the specific clutch lock tool.

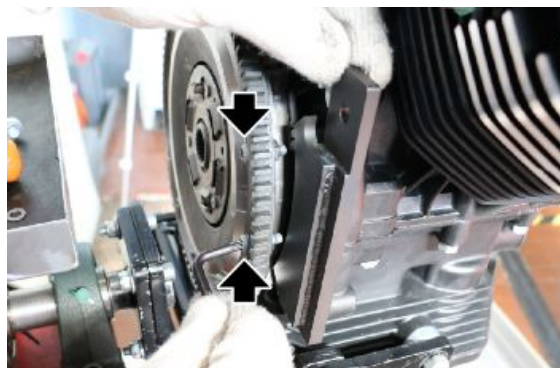

Specific tooling

021001Y Clutch lock

- Using one of the fixing screws of the gearbox assembly, secure the specific tool.

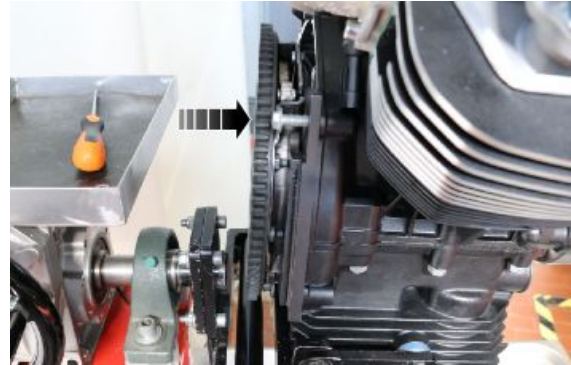

- Place the tool (1) on the rotor, tighten the threaded pin (2) of the tool and proceed with the rotor removal



Specific tooling

020713Y Flywheel extractor

OIL SEAL REMOVAL

- Operating in the alternator cover, to remove the oil seal of engine oil circuit system sealing, the seeger must be removed



- Remove the washer



- Extract the oil seal



STATOR REMOVAL

- Remove the stator wiring harness lock plate



- Removing the three stator fixing screws makes it possible to disconnect it

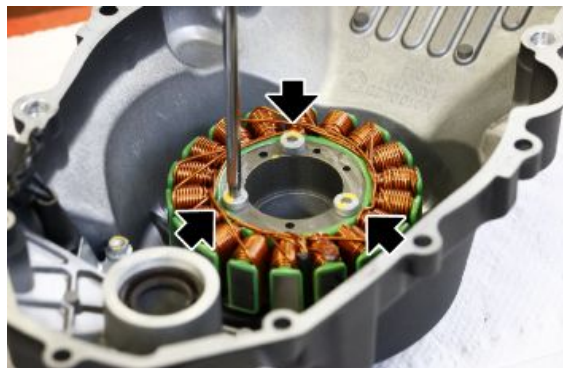

Generator Installation

- During refitting of the flywheel cover it is necessary to apply a great amount of threebond on the cable grommet of the stator before placing it in its seat

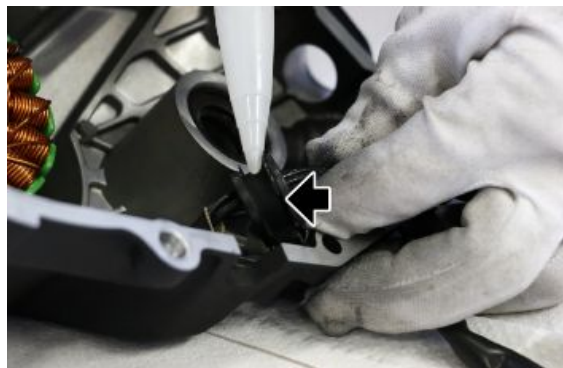

- Check that plentiful threebond leaks out and covers all space between the seat on the cover and the cable grommet. Apply another layer of threebond over the cable grommet.



- Refit a new gasket.



Starter motor

Removing the starter motor

- Remove the starter motor fixing screws (1)



- Remove the supporting clamp of the protection (2) and the starter motor (3)

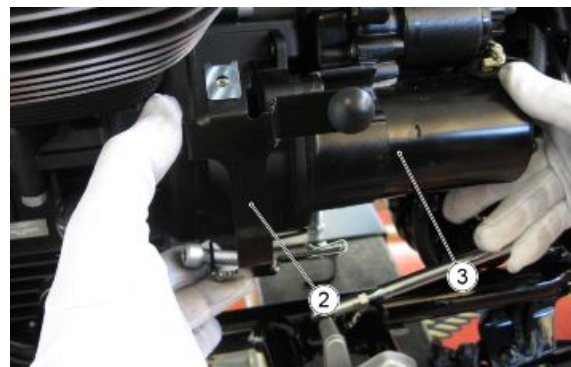

Clutch side

Disassembling the clutch

- Remove the clutch cover.
- Partially unscrew the two fixing screws of the clutch plate, as indicated, to allow the correct positioning of the specific clutch lock tool.

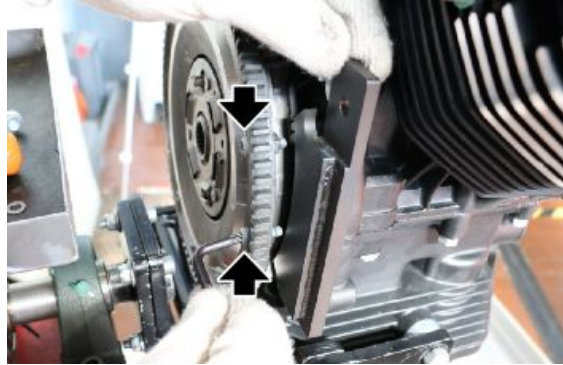

Specific tooling

021001Y Clutch lock

- Using one of the fixing screws of the gearbox assembly, secure the specific tool.

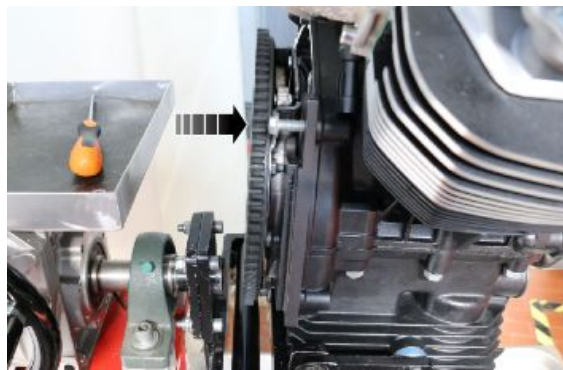

- Remove the 6 fixing screws of the clutch plate complete with starter sprocket

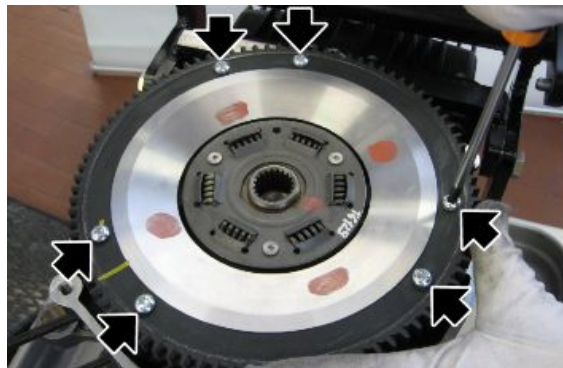

- Remove the clutch plate complete with starter sprocket



- Remove the clutch disc.



- Remove the retainer ring



- Remove the thrust plate



- Remove the 6 fixing screws of the locking plate



- Remove the reinforcement flange of the clutch thrust plate



- Remove the clutch lock complete



- Remove the spacer plate.



Checking the clutch plates

Clutch disc

Make sure that the clutch plate is not scratched or badly worn. Check the flexible springs and the thickness of the clutch disc

Characteristic

Minimum disc wear thickness

0.9 mm (0.04 in)

Starting sprocket

Check that the supporting surface with the driven plate is perfectly smooth and even.

Also check that the tothing where the starter motor pinion works is not chipped or scratched; otherwise, replace it.



Assembling the clutch

- Insert the spacer plate on the crankshaft.



- Insert the complete clutch lock.



- Place the reinforcement flange of the clutch thrust plate, aligning the holes with the ones of the clutch base



- Insert the 6 fastening screws complete with washers and tighten to the prescribed torque



- Insert the thrust plate cap



- Lock the thrust plate using the special lock ring

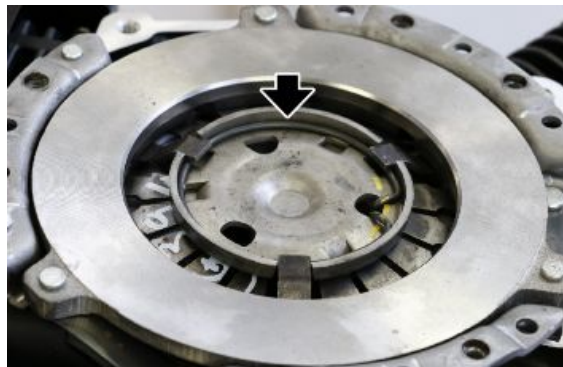

- Place the clutch plate



- Place the starter sprocket and screw the fixing screws by hand



- Using the special tool for the centring of the clutch plate

Specific tooling

021002Y Clutch centring



- Insert the six fastening screws at the recommended torque.



Bushing selection

CRANKSHAFT - CRANKCASE BUSHINGS

The crankcase class is stamped in the following locations:

- Above the crankshaft hole on the alternator side.
- Next to the crankshaft hole on the clutch side.

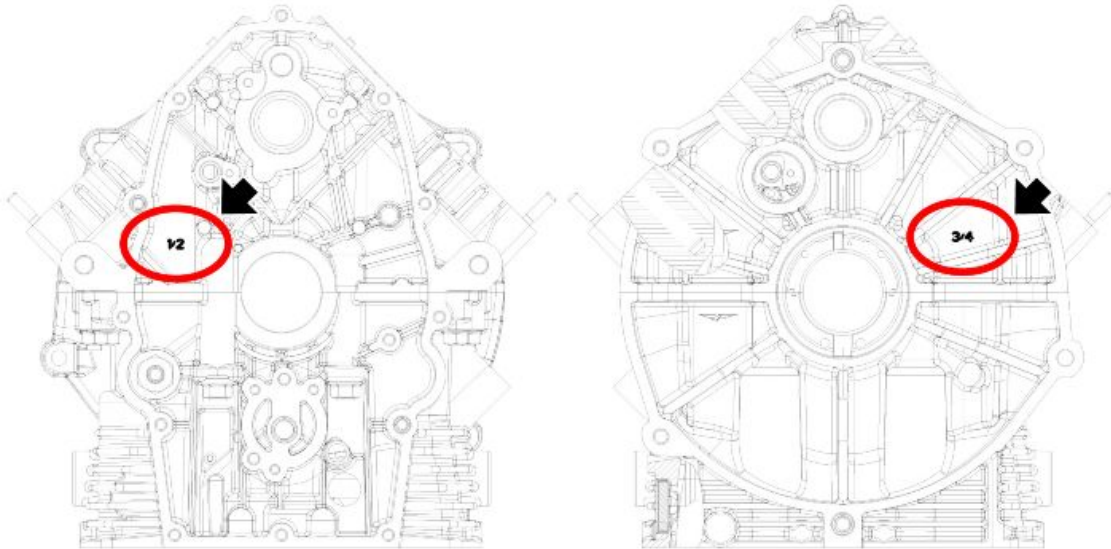

CRANKCASE HOLE DIAMETER

| Specification | Desc./Quantity |
|---------------|--|
| Class 1 | Bushing seat diameter: 43.657-43.663 mm (1.7188-1.7190 in) |
| Class 2 | Bushing seat diameter: 43.664-43.670 mm (1.7191-1.7193 in) |
| Class 3 | Bushing seat diameter: 47.130-47.136 mm (1.8555-1.8557 in) |
| Class 4 | Bushing seat diameter: 47.137-47.142 mm (1.8558-1.8560 in) |

Four different crankcase classes are available:

- (1-2) according to diameter of hole in half crankcase shells on alternator side.
- (3-4) according to diameter of hole in half crankcase shells on clutch side.

CRANKSHAFT

The crankshaft class is stamped on the crankshaft counterweights

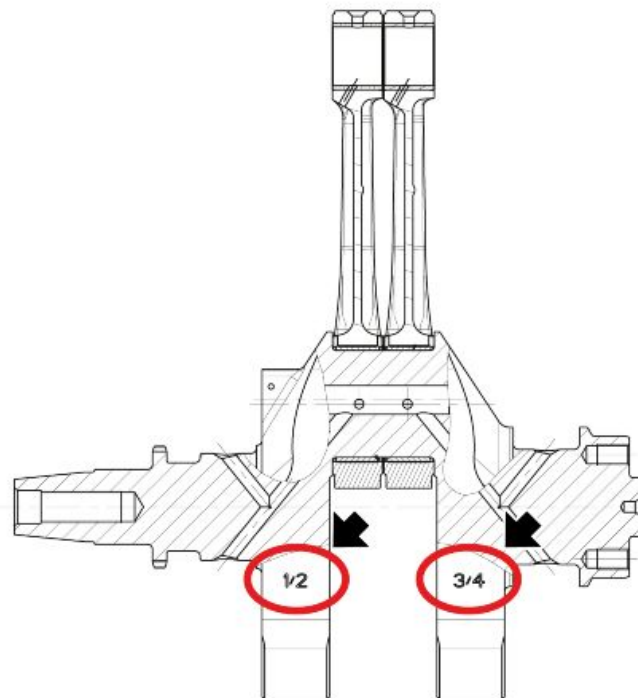

MAIN CRANKSHAFT JOURNAL DIAMETER

| Specification | Desc./Quantity |
|---------------|---|
| Class 1 | Diameter: 40.004-40.012 mm (1.5750-1.5753 in) |
| Class 2 | Diameter: 40.013-40.020 mm (1.5753-1.5756 in) |
| Class 3 | Diameter: 43.007-43.015 mm (1.6932-1.6935 in) |
| Class 4 | Diameter: 43.016-43.023 mm (1.6935-1.6937 in) |

Four different crankshaft classes are available:

- (1-2) according to main journal diameter on alternator side.
- (3-4) according to main journal diameter on clutch side.

SELECTING CRANKSHAFT - CRANKCASE BUSHING CLASSES

| Crankcase class | Class 1 crankshaft | Class 2 crankshaft | Class 3 crankshaft | Class 4 crankshaft |
|-----------------|--------------------|--------------------|--------------------|--------------------|
| Class 1 | green-green | yellow-yellow | - | - |
| Class 2 | black-black | green-green | - | - |
| Class 3 | - | - | green-green | yellow-yellow |
| Class 4 | - | - | black-black | green-green |

CRANKSHAFT - CRANKCASE BUSHINGS

The crankcase class is stamped in the following locations:

- Alternator side, on the upper crankcase in correspondence with the crankshaft hole, on the left.
- Clutch side, on the upper crankcase in correspondence with the crankshaft hole, on the right.

Head and timing

Removing the head cover

NOTE

THE OPERATIONS FOR THE REMOVAL OF THE HEAD COVER ARE THE SAME FOR BOTH SIDES

- Remove the spark plug cover
- Disconnect the spark plug tube
- Remove the blow-by pipe
- Undo the three fixing screws of the head cover and remove the gasket

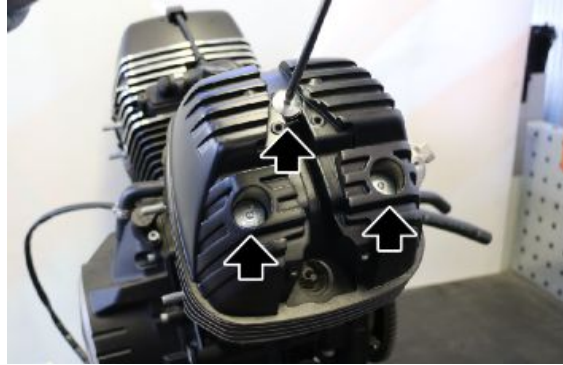

- Remove the head cover together with the gaskets



- Remove the gasket from the head cover



- Check that the mating faces that contact the heads are not damaged or blistered

Removing the cylinder head**NOTE**

THE HEAD REMOVAL OPERATIONS REFER TO ONE HEAD BUT APPLY TO BOTH

- Remove the head cover
- Unscrew the spark plug



CAUTION



THE INTAKE VALVE IS CHARACTERIZED BY THE PRESENCE OF A CALIBRATED PAD, THEREFORE PAY PARTICULAR ATTENTION TO RECOVER IT DURING DISASSEMBLY.



- Remove the fastening screw of the rocker pin retainer fork

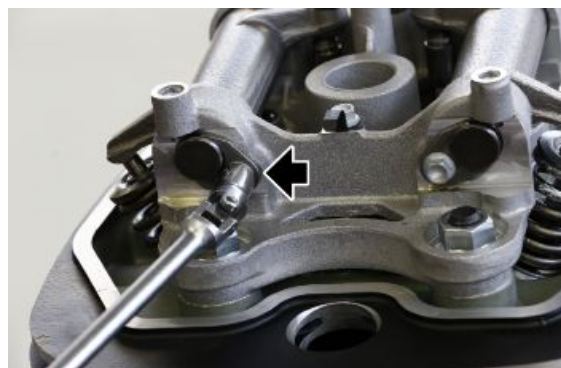

- Remove the rocker pin retainer fork



- Remove the rocker pin

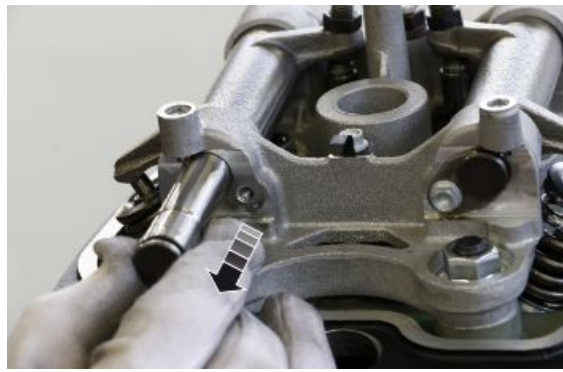

- Remove the rocker, being careful to recover the Belleville spring

NOTE
 REPEAT THE SAME PROCEDURE TO REMOVE THE OTHER ROCKER

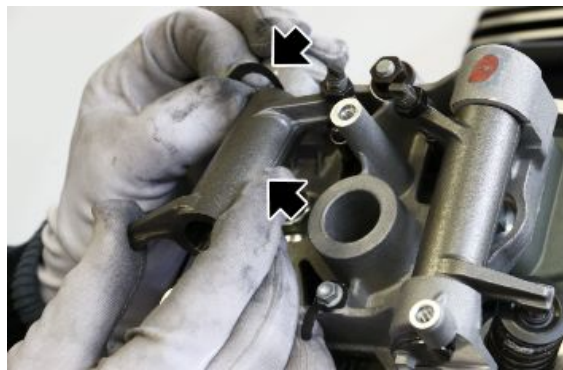

- Remove the rocker rods

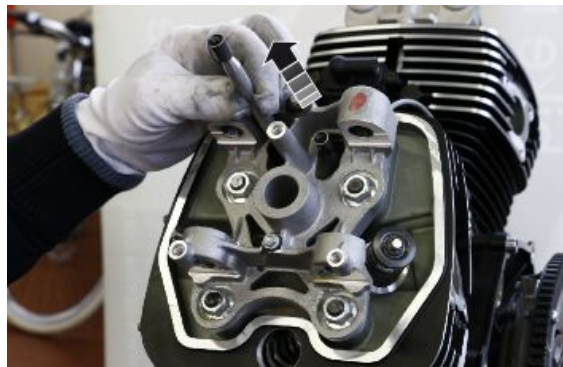

- Unscrew and remove the compensation nut of the cam tower



- Undo and remove the fastening nuts of the cam tower

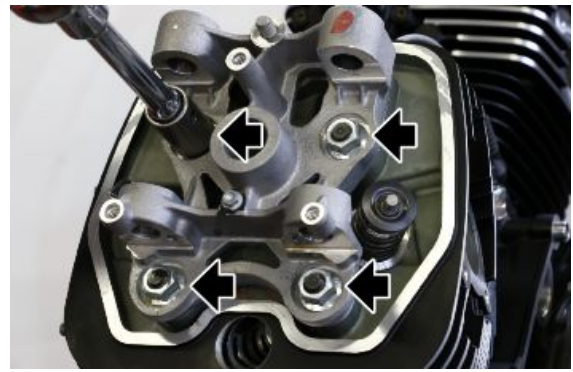

- Remove the cam tower



- Remove the three rubber O-Rings

CAUTION



PAY SPECIAL ATTENTION THAT THE O-RINGS DO NOT ACCIDENTALLY FALL INTO THE PROCESSING HOLES OF THE ROCKERS RODS

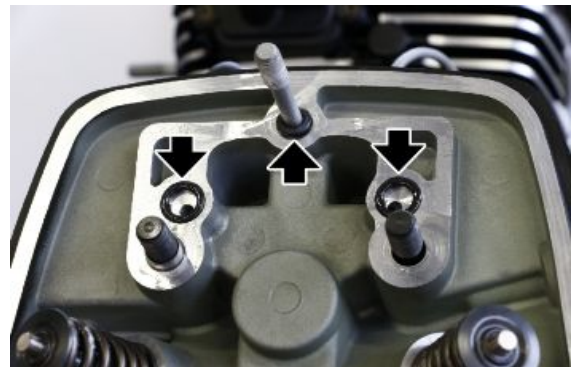

- Remove the complete head



- Remove the cylinder head gasket



- Undo and remove the engine oil pressure sensor



- Undo and remove the secondary air valve cover



- Remove the secondary air valve
- check and if necessary replace the external rubber gasket



- Remove the internal filter paying attention to the direction during refitting



Cylinder head

Removing the valves

- Place the special tool on the upper cap of the valve to be removed and at the centre of the head of the valve.

Specific tooling

020382Y Tool to extract valve cotters



- Close the tool to compress the spring and remove the two half-cones from the upper cap

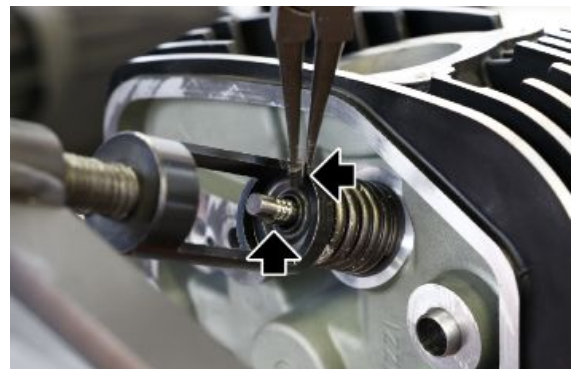

- Unscrew the tool and remove it from the head
- Remove the upper cap



- Remove the spring and replace it if it is out of the wear limit.



- Remove the valve from the head



- Remove the gasket of the valve guide



VALVE GUIDES MUST BE REPLACED WHEN THEY ARE WORN TO THE POINT THAT REPLACING THE VALVE ALONE IS NOT ENOUGH TO ELIMINATE CLEARANCE BETWEEN VALVE STEM AND VALVE GUIDE BORE.



- Remove the lower cap of the spring



Checking the rocker arms

- Check that the bolt surface that contacts the rockers is not exceedingly worn.
- Check the rocker to valve and rocker to rod contact surfaces.



Valve check

If the below shown values are out of the limits of the component wear, replace it

Intake valves:

Characteristic

Coupling clearance between valve and guide (WEAR LIMIT)

0.05 mm (0.0020 in)

Valve stem distortion (MEASURED ON 45°)

0.03 mm (0.0012 in)

Valve stem diameter (MINIMUM WEAR VALUE)

5.95 mm (0.2342 in)

Valve head eccentricity (MAXIMUM ALLOWED VALUE)

0.05 mm (0.0020 in)

Outlet valves:

Characteristic

Coupling clearance between valve and guide (WEAR LIMIT)

0.06 mm (0.0024 in)

Valve stem distortion (MEASURED ON 45°)

0.03 mm (0.0012 in)

Valve stem diameter (MINIMUM WEAR VALUE)

5.92 mm (0.2331 in)

Valve head eccentricity (MAXIMUM ALLOWED VALUE)

0.05 mm (0.0020 in)

Inspecting the springs and half-cones

- Check that the upper spring caps and the half-cones show no signs of abnormal wear.
- Check the unloaded spring length.

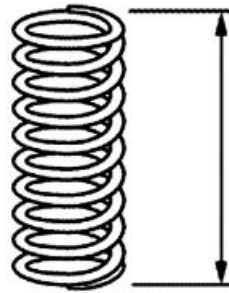

Characteristic

Spring free length (WEAR LIMIT)

45.9 mm (1.81 in)

Adjusting valve clearance

- Bring the piston of the left cylinder to top dead centre making sure that the reference mark on the crankshaft gear and on the timing system shaft are aligned.

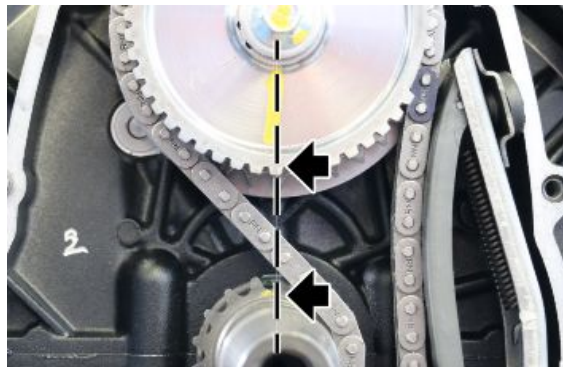

- Use a feeler gauge to check that the clearance between the valve and the set screw corresponds with the indicated values. The corresponding intake and outlet valve clearances are different than what is indicated below, proceed with adjusting them.



Characteristic

Intake valve clearance

0.10 mm (0.0039 in)

Exhaust valve clearance

0.15 mm (0.0059 in)

- Loosen the lock nut, adjust the clearance by acting on the adjuster until reaching the prescribed values
- Tighten the lock nut

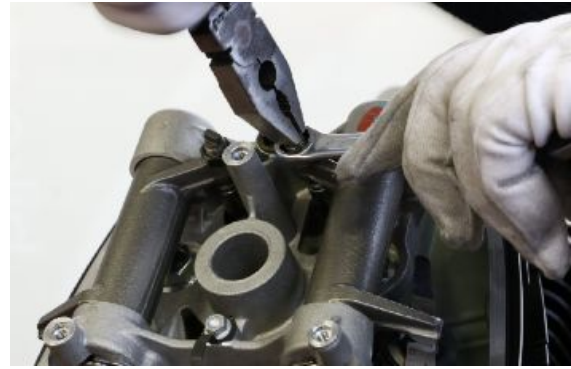

Timing

Rimozione ruota fonica

- Remove the timing system cover.
- Remove the rotor.
- Remove the screw fastening and washer of the tone wheel.

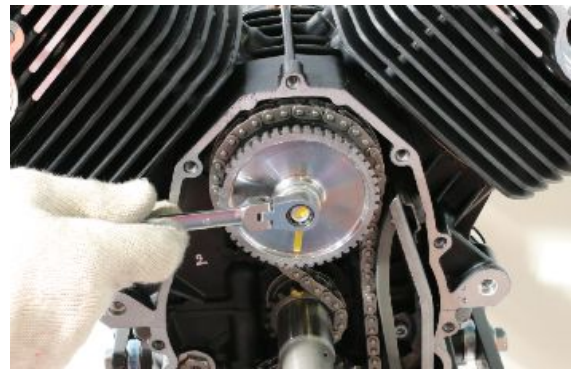

- Remove the tone wheel



Removing the chain tensioner

- Remove the timing system cover
- Remove the rotor
- Remove the chain tensioner fixing screw recovering the washer

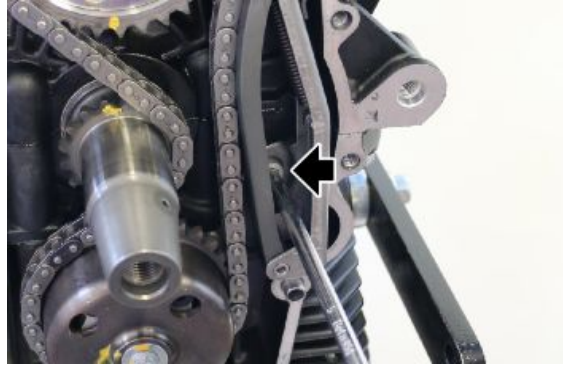

- Remove the chain tensioner



Chain removal

- Remove the timing system cover, the rotor and the tone wheel.
- Remove the three fixing screws of the timing gear.

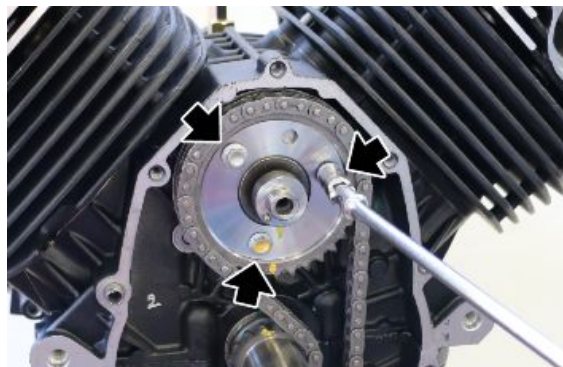

- Remove the fixing screw with relative washer for the oil pump gear.



- Remove the timing chain, removing the camshaft gear and the oil pump gear at the same time



Rimozione piattello blow-by

- Remove the timing system cover, the rotor and tone wheel complete with spacer
- Remove the blow-by cap



Removing the camshaft

WARNING

THE BUCKET TAPPETS MUST BE REMOVED IN ORDER TO DISASSEMBLE THE CAMSHAFT.

- Remove the timing system cover, the rotor, the tone wheel, the timing system with gear and the blow-by cap.
- Remove the two fixing screws of the camshaft.

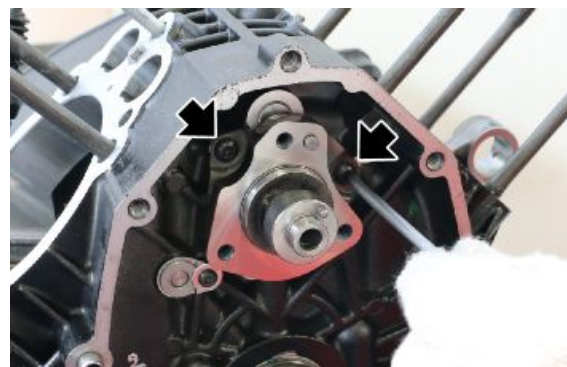

- Remove the camshaft extracting it from the crankcase.

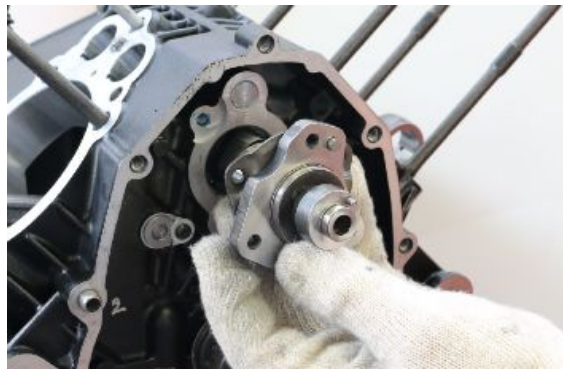

Installing the camshaft

- Insert the camshaft into the crankcase.



- Place the two fixing screws and tighten them to the prescribed torque.

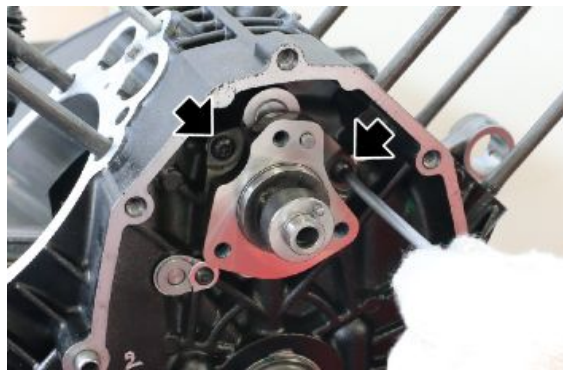

Installazione piattello blow-by

- Place the blow-by cap on the camshaft making the holes and the special timing plug match



Installazione catena

- For the installation of the timing chain, it is necessary to carry out the "Timing" procedure, therefore consult the specific chapter.

See also

[Timing](#)

Installing the phonic wheel

- Fit the tone wheel checking the correct positioning on the camshaft, using the centring plug



- Insert the screw complete with washer to fasten the tone wheel and tighten it to the prescribed torque.



Cam timing

Timing

- Bring the piston of the left cylinder to top dead centre making sure that the reference mark on the crankshaft gear is up on the perpendicular axis and that the rocker have clearance



- Having positioned the blow-by cap, fit the timing chain together with timing system gear and oil pump gear.

WARNING

PRIOR TO POSITIONING THE TIMING CHAIN WITH GEAR, ALIGN AS MUCH AS POSSIBLE THE MILLING PRESENT ON THE OIL PUMP PIN WITH THE GEAR OF THE PUMP ITSELF, TO ALLOW THE INSERTION OF THE SAFETY PLUG.

**CAUTION**

CHECK THE CORRECT INSTALLATION USING THE ALIGNMENT OF THE REFERENCE NOTCHES ON THE CRANKSHAFT AND ON THE TIMING SYSTEM GEAR

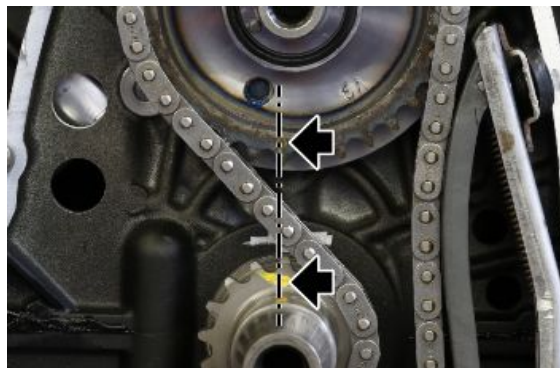

- Using a thin tool, refine the alignment of the oil pump pin with the milling on the gear of the pump itself.



- Fit the safety plug.



- Fit the knurled washer and after placing the nut, tighten it to the prescribed torque



- Position the three fixing screws of the timing gear and tighten to the prescribed torque.

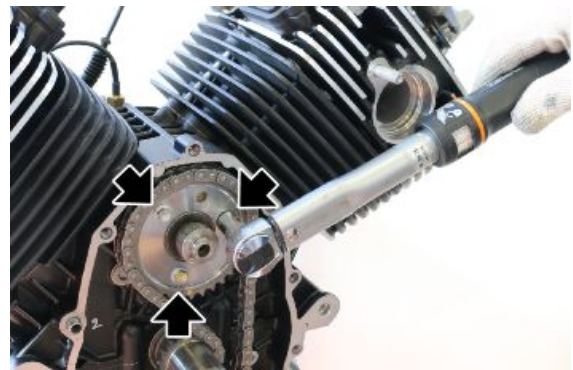

- Position the tone wheel and after inserting the fixing screw with washer, tighten to the prescribed torque.



- Turn the crankshaft manually checking that there is no jamming. If jamming does occur, repeat the timing operation

Cylinder-piston assembly

Removing the cylinder

- Remove the nut with relevant washer of the cylinder to the crankcase



- Slide off the cylinder from the stud bolts.



- Remove the gasket from the stud bolts



Disassembling the piston

- Remove one of the two retainer rings from the pin paying attention that it does not fall inside the engine



- Before removing the pin, check the mounting clearance between pin and piston. Replace it if the value is out of the limits
- Slide off the pin



Characteristic

Mounting clearance between piston and pin

0.01 mm (0.0004 in)

- Remove the piston

CAUTION

DURING SERVICING, CLEAN OFF ANY DEPOSITS FROM PISTON CROWN AND CIRCLIP GROOVES



Checking the cylinder

- After checking for scoring, check cylinder surface wear using a dial gauge graduated in hundredths of a millimetre.
- Measure the inner diameter of the cylinders at three different heights, turn the dial gauge (graduated in hundredths of a millimetre) 90° and repeat the measurements; set the dial gauge graduated in hundredths of a millimetre to zero using a ring gauge before measuring.

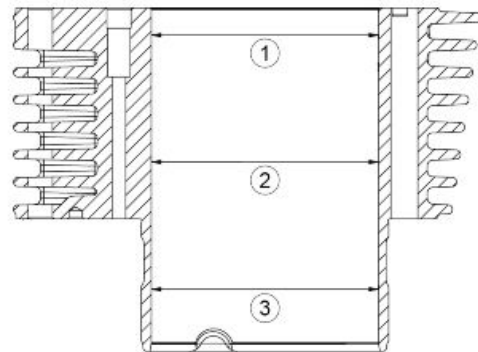

Key:

1. 1st measurement
2. 2nd measurement
3. 3rd measurement

CYLINDERS CONTROL

| Type | Allowed diameter | Assembly clearance between piston and cylinder |
|------|-------------------------------------|--|
| G | 84.000-84.007 mm (3.3071-3.3073 in) | 0.040-0.054 mm (0.0016-0.0021 in) |

| Type | Allowed diameter | Assembly clearance between piston and cylinder |
|------|-------------------------------------|--|
| H | 84.007-84.014 mm (3.3074-3.3076 in) | 0.040-0.054 mm (0.0016-0.0021 in) |
| L | 84.014-84.021 mm (3.3076-3.3079 in) | 0.040-0.054 mm (0.0016-0.0021 in) |
| M | 84.021-84.028 mm (3.3079-3.3082 in) | 0.040-0.054 mm (0.0016-0.0021 in) |

Checking the piston

- Measure the piston skirt diameter (1) with a micrometer from the piston lower border (2)=10 mm (0.39 in).
- Replace the cylinder, the piston and the piston ring all together if not complying with specifications.

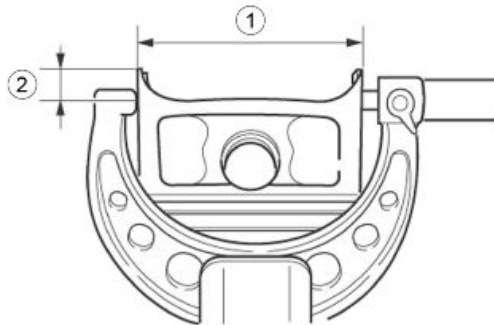

INSPECTING PISTONS

| Type | Allowed diameter | Assembly clearance between piston and cylinder |
|------|-------------------------------------|--|
| G | 83.953-83.960 mm (3.3052-3.3055 in) | 0.040-0.054 mm (0.0016-0.0021 in) |
| H | 83.960-83.967 mm (3.3055-3.3058 in) | 0.040-0.054 mm (0.0016-0.0021 in) |
| L | 83.967-83.974 mm (3.3058-3.3061 in) | 0.040-0.054 mm (0.0016-0.0021 in) |
| M | 83.974-83.981 mm (3.3061-3.3063 in) | 0.040-0.054 mm (0.0016-0.0021 in) |

Inspecting the wrist pin

PIN

- Clean off combustion residues from the piston crown and from the area above the top ring.
- Check for cracks on the piston and for compression on the piston sliding surface (seizing); Replace the piston if required.
- Measure the pin outside diameter (1) and if not complying with specifications; replace the pin.

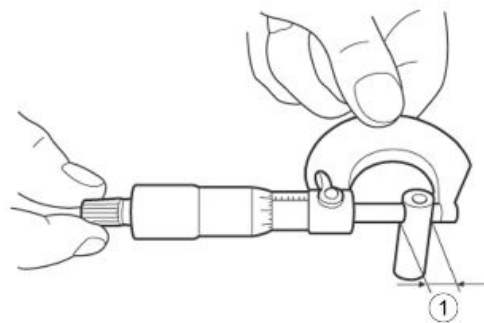

Characteristic

Pin external diameter (MINIMUM WEAR VALUE)

19.996 mm (0.7872 in)

Inspecting the piston rings

- Clean off any carbon deposits from the grooves in the piston rings and from the rings themselves.
- Measure the piston ring side clearance and replace the piston and the piston rings all together if not complying with specifications.

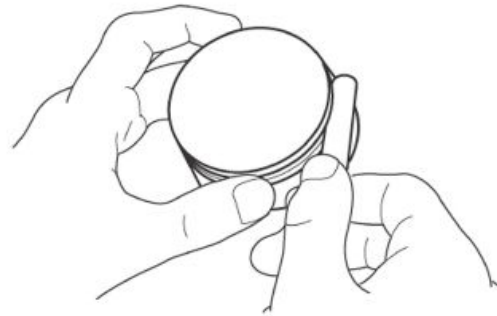

SEAL RING CLEARANCE (MAXIMUM WEAR VALUES)

| Type | Maximum clearance between the rings and cables on the piston | Maximum opening of the rings mounted on the piston |
|-------------------|--|--|
| Upper ring | 0.07 mm (0.0028 in) | 0.10-0.30 mm (0.0039-0.0118 in) |
| Intermediate ring | 0.06 mm (0.0024 in) | 0.35-0.55 mm (0.0138-0.0217 in) |
| Oil scraper ring | 0.18 mm (0.0071 in) | 0.20-0.70 mm (0.0079-0.0276 in) |

- Fit the piston ring to the cylinder.
- Level the installed piston ring with the piston crown.
- Measure piston ring port and replace it if not complying with specifications.

CAUTION

IT IS NOT POSSIBLE TO MEASURE THE CLEARANCE OF THE END OF THE OIL SCRAPER RING: IF THERE IS EXCESSIVE PLAY, REPLACE THE THREE ELASTIC RINGS.

- Insert the piston rings paying attention to their mounting direction and end gap arrangement; the end gaps must be approximately 180 degrees from each other.

Fitting the piston

- Place the piston on the connecting rod notch

CAUTION

MOUNTING POSITION IS INDICATED BY AN ARROW POINTING IN THE DIRECTION OF TRAVEL



- Insert the pin



- Insert the retainer ring

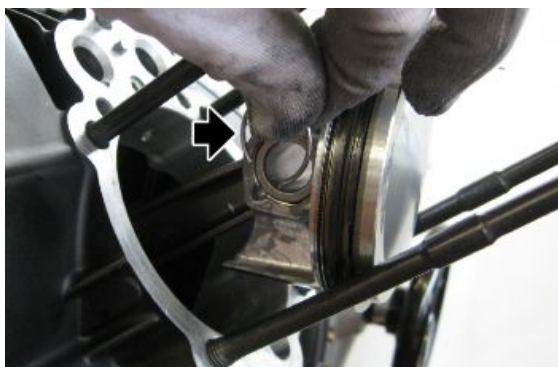

Installing the cylinder

- Check that the piston ring end gaps are approximately 120 degrees from each other.
- Fit a new gasket



- Place the appropriate ring clamp on the piston
- Place the cylinder so that the piston correctly enters the seat and as soon as the segments zone is exceeded remove the ring clamp



Specific tooling

020128Y Piston ring compressor

- After fitting the cylinder it is necessary to check the piston projection for correct head gasket selection.
- Fit a dial gauge on the specific tool and set it to zero on a horizontal plane.



Specific tooling

020996Y Piston protrusion measuring tool

- Fit the tool together with the dial gauge on the cylinder and tighten the fixing nuts.
- Detect the deviation on the dial gauge



Specific tooling

020996Y Piston protrusion measuring tool

CAUTION

THE PISTON PROJECTION MUST BE DETECTED BY FITTING THE GASKET BETWEEN CRANK-CASE AND CYLINDER. BEFORE THE DETECTION TIGHTEN THE CYLINDER UNTIL THE GASKET IS COMPLETELY WOUND

HEAD GASKET SELECTION

| Piston projection | Gasket thickness |
|---------------------------------|--|
| 0.40-0.58 mm (0.0157-0.0228 in) | 0.6 +/- 0.05 mm (0.0236 +/- 0.0020 in) |
| 0.20-0.40 mm (0.0079-0.0157 in) | 0.8 +/- 0.05 mm (0.0315 +/- 0.0020 in) |
| 0.02-0.20 mm (0.0008-0.0079 in) | 1.0 +/- 0.05 mm (0.0394 +/- 0.0020 in) |

- Once the correct gasket has been identified, position the washer with the relevant nut on the base of the cylinder and tighten to the prescribed torque.



Installing the cylinder head

- Insert the flame trap of the secondary air valve



- Insert the reed valve



- Fit the cover of the secondary air valve and tighten the screws to the prescribed torque



- Fit the engine oil pressure sensor, only in the left head and tighten it to the prescribed torque



- Place the gasket



- Place engine head into place



- Place the three rubber O-Rings, particularly apply grease to the O-Ring that will be inserted in the stud bolt in order to avoid damaging it

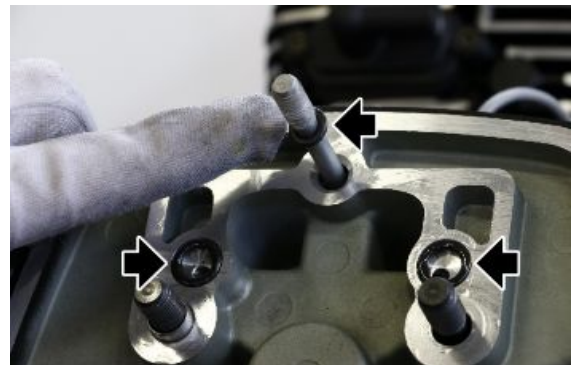

- Position the cam tower in its seat



- Following a cross order "A-C-B-D" screw the fixing nuts of the cam tower to the prescribed torque

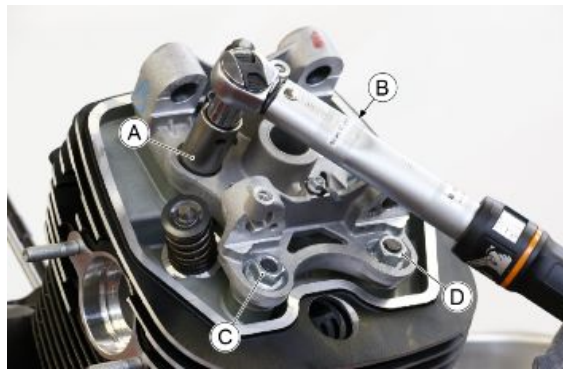

- Insert and tighten the compensation nut of the cam tower to the prescribed torque

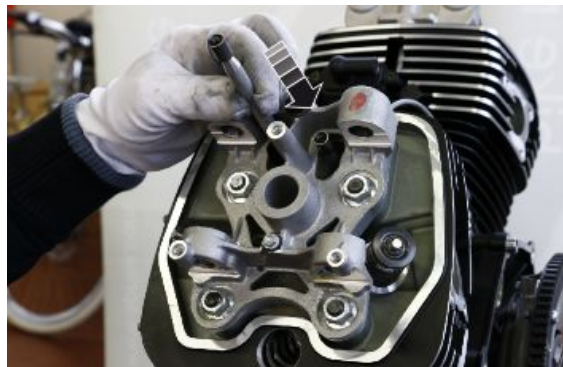

- Insert the rocker rods

**CAUTION**

PRIOR TO POSITIONING THE ROCKERS, CHECK THAT THE CALIBRATED PAD ON THE INTAKE VALVE IS INSERTED.

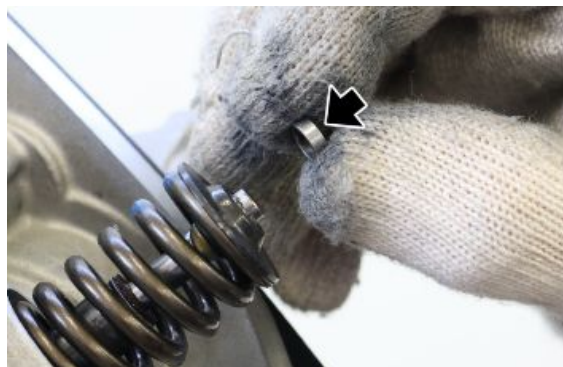

- Place the rocker in its seat by inserting the Belleville spring at the same time

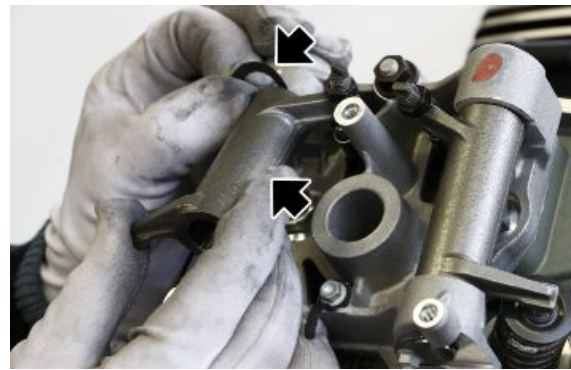

- Using the rocker shim centring pin, align the rocker and the Belleville spring with the pin seat for easy insertion

Specific tooling

020995Y Rocker arm centring pin

- Insert the rocker pin retainer fork on the pin and insert it in the seat

CAUTION

SLOWLY INSERT THE ROCKER PIN UNTIL THE FORK REACHES THE SUPPORT POINT ON THE CAM TOWER. THE INSERTION OF THE ROCKER PIN WITHOUT THE FORK REACHES A NON-CONTROLLED DEPTH

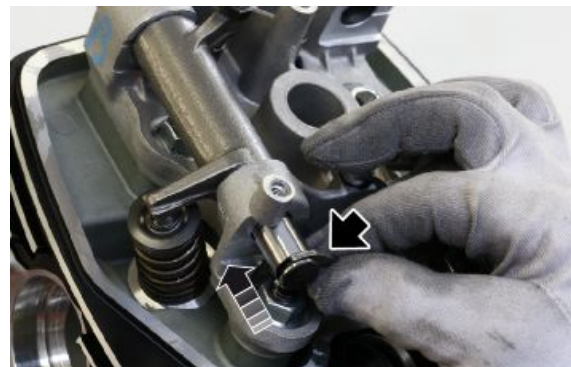

- Insert and tighten the fixing screw of the rocker pin lock fork to the prescribed torque

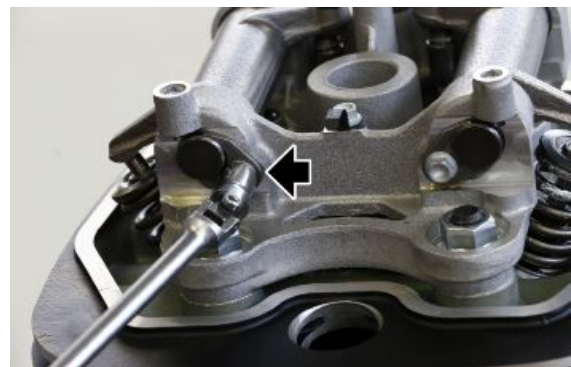

- Insert and tighten the spark plug to the prescribed torque



Installing the head cover

- Fit the gasket on the head cover



- Place the head cover together with the gaskets on the seats of the fixing screws



- Place the cover fixing screws and tighten them to the prescribed torque

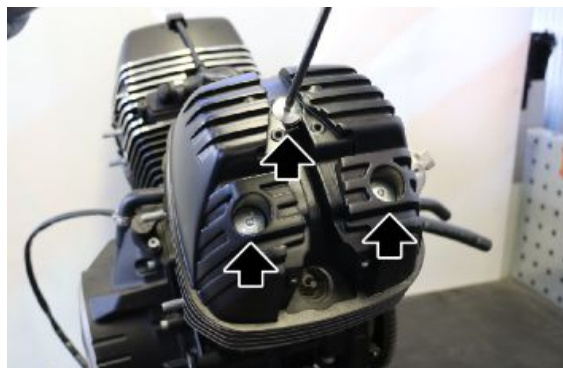

Crankcase - crankshaft

Splitting the crankcase halves

- Remove the bucket tappets, the oil sump, the filter and the overpressure valve.
- Unscrew and remove the six external nuts and their washers.

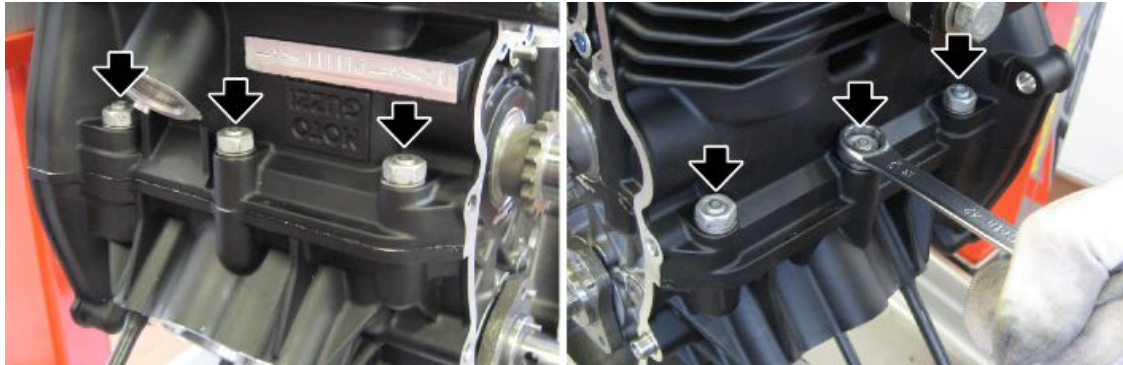

- Undo and remove the four long nuts from the inside of the crankcase.

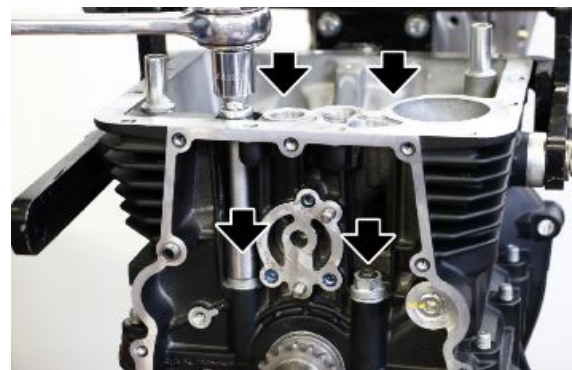

- Remove the upper crankcase being careful not to damage its mating face



- Remove the crankshaft together with connecting rods and small ends



Removing the crankshaft

- Remove the crankshaft connecting rods.
- Unscrew the oil plug and thoroughly clean the oilway and oil passages delivering oil to connecting rods and main journals.

See also

[Disassembling the connecting rod](#)

Disassembling the connecting rod

- Remove the screws and separate the connecting rod from the small end paying attention to the reference signs and the mounting direction.



- Remove the small ends from the connecting rods.

CAUTION

REPEAT THE PROCEDURE FOR THE OTHER CONNECTING ROD

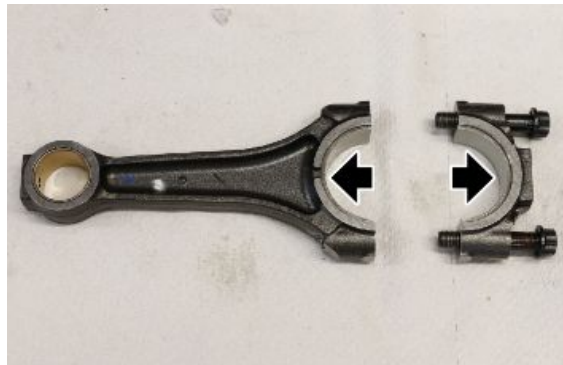

Inspecting the crankcase halves

- Check that the mating faces are not damaged, dented or scored. Remove the liquid gasket residues.
- Check that the threads of the stud bolts are not dented or stripped; if they are, replace the stud bolt or stud bolts.
- Blow all oil galleries of the two crankcase halves with compressed air.

Inspecting the crankshaft components

- Smear the thread of the cap with threadlocker and tighten the cap firmly.
- Blow with compressed air to clean the lubrication passage seats.

CAUTION

THE CRANKSHAFT IS NITRIDED AND CANNOT BE GROUND; IF WORN, TAPERED OR DEEPLY SCORED, THE CRANKSHAFT MUST BE REPLACED

CRANKSHAFT CHECK - LIMIT VALUES

| Specification | Desc./Quantity |
|---|-----------------------|
| Main journal diameter on timing system side (WEAR LIMIT VALUE) | 40.004 mm (1.5750 in) |
| Main bushing seat diameter on timing system side (MAXIMUM WEAR VALUE) | 43.67 mm (1.7193 in) |
| Thickness for main bushing on timing system side (MAXIMUM WEAR VALUE) | 1.805 mm (0.0711 in) |
| Main journal diameter on clutch side (MINIMUM WEAR VALUE) | 43.007 mm (1.6932 in) |
| Main bushing seat diameter on clutch side (WEAR LIMIT VALUE) | 47.142 mm (1.8560 in) |
| Total thickness for main bushing on clutch side (MINIMUM WEAR VALUE) | 2.04 mm (0.0803 in) |
| Crankshaft thrust height (MAXIMUM WEAR VALUE) | 24.81 mm (0.9768 in) |
| Crankcase thrust height (MINIMUM WEAR VALUE) | 2.3 mm (0.0905 in) |
| Thickness of the thrust half-bearings on main bushing on clutch side (MINIMUM WEAR VALUE) | 2.31 mm (0.0909 in) |
| Diameter of crank pin (MINIMUM WEAR VALUE) | 39.995 mm (1.5746 in) |

The maximum parallelism deviation of the two crankshaft axes (connecting rod pin and main journals on flywheel side and timing system side) should not exceed 0.02 mm (0.0009 in) at 40 mm (1.5748 in) distance.

Checking the connecting rod

- Check using a micrometer the measure of the connecting rod pin orthogonal axes in the working area of the small ends, check the measure of the small ends seats on the timing system side and on the flywheel side.
- Assemble the connecting rod without small ends and tighten the connecting rod screws to the prescribed torque. Measure the outer diameter of small ends seats with a dial gauge graduated in hundredths of a millimetre and the thickness of both small ends with a round tip micrometer.
- Check the bushings pressed in the small end of the connecting rod for notches due to seizing or deep scoring; replace as required.

CONNECTING ROD CHECK

| Specification | Desc./Quantity |
|---|-----------------------|
| Diameter connecting rod head seat (MAXIMUM WEAR VALUE) | 43.67 mm (1.7193 in) |
| Thickness of connecting rod head small ends (MINIMUM WEAR VALUE) | 1.807 mm (0.0711 in) |
| Diameter of the small end with pressed and bored bushing (MAXIMUM WEAR VALUE) | 20.015 mm (0.7880 in) |

Assembling the connecting rod

- Before assembly, take careful note of the reference markings and the correct direction of installation.

- Connecting rods are available in two selections (A/blue - B/white, identified respectively by a white or blue dot in the zone indicated by the letter X in the drawing). These must be assembled correctly with the crankshaft, which is categorised into two different selections in relation to crankpin size (A/blue - B/white, identified respectively by a white or blue dot in the zone indicated by the letter Y in the drawings), using the appropriate bushing.

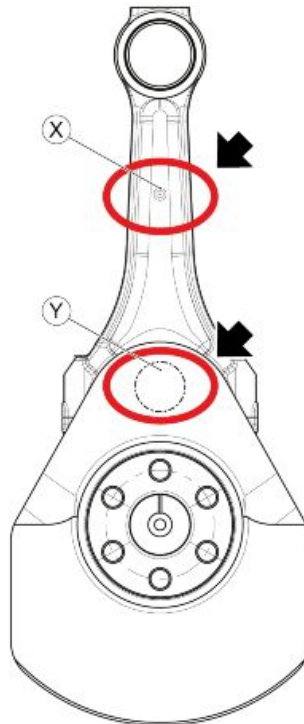

CONNECTING ROD HEAD BUSHING CLASSES

| Selection class | Thickness |
|-----------------|-----------------------------------|
| Red | 1.807-1.811 mm (0.0711-0.0713 in) |
| Blue | 1.811-1.815 mm (0.0713-0.0715 in) |
| Yellow | 1.815-1.819 mm (0.0715-0.0716 in) |

CONNECTING ROD/CRANKSHAFT CLASSES

| Selection class | Connecting rod big end diameter | Crankshaft diameter |
|-----------------|-------------------------------------|-------------------------------------|
| A (light blue) | 43.657-43.664 mm (1.7188-1.7191 in) | 39.995-40.003 mm (1.5746-1.5749 in) |
| B (white) | 43.664-43.670 mm (1.7191-1.7193 in) | 40.003-40.011 mm (1.5749-1.5752 in) |

CONNECTING ROD/CRANKSHAFT ASSEMBLY CLASSES

| Connecting rod selection class | Blue crankpin marking | White crankpin marking |
|--------------------------------|-----------------------|------------------------|
| A (light blue) | blue-blue | red-red |
| B (white) | yellow-yellow | blue-blue |

- The radial play between the connecting rod and the crankshaft must be within the following range: 0.045-0.069 mm (0.0018-0.0027 in)
- The identifying color point of the connecting rod selection must be oriented for both connecting rods towards the clutch side.

- Before assembly, take careful note of the coupling classes.
- Assemble the connecting rod on the crankpin in the crankcase, tightening the screws to the indicated torque.

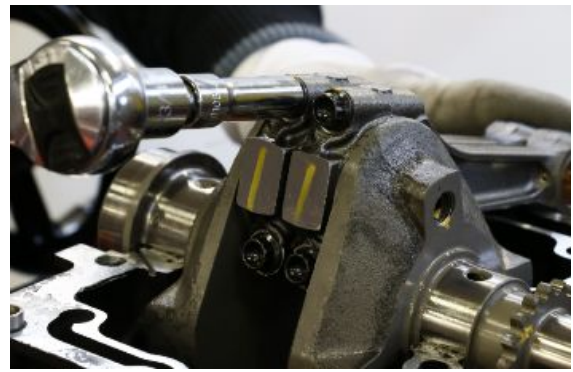

Refitting the crankcase halves

- Insert the small ends timing system side and flywheel side on both crankcases paying attention to lubricate them

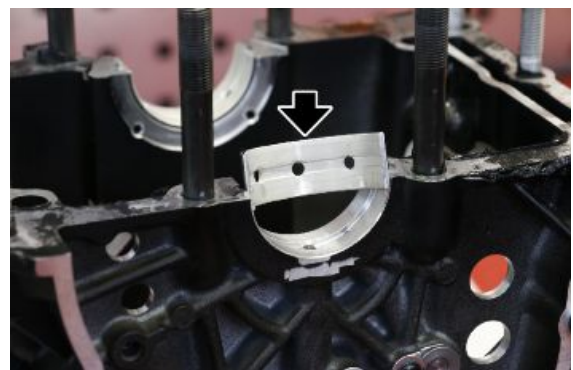

- With the help of grease, place the thrusts on the upper crankcase from the flywheel side, paying attention to lubricate them in the friction area

CAUTION

THE MOUNTING DIRECTION OF THE THRUSTS IS UNIQUE

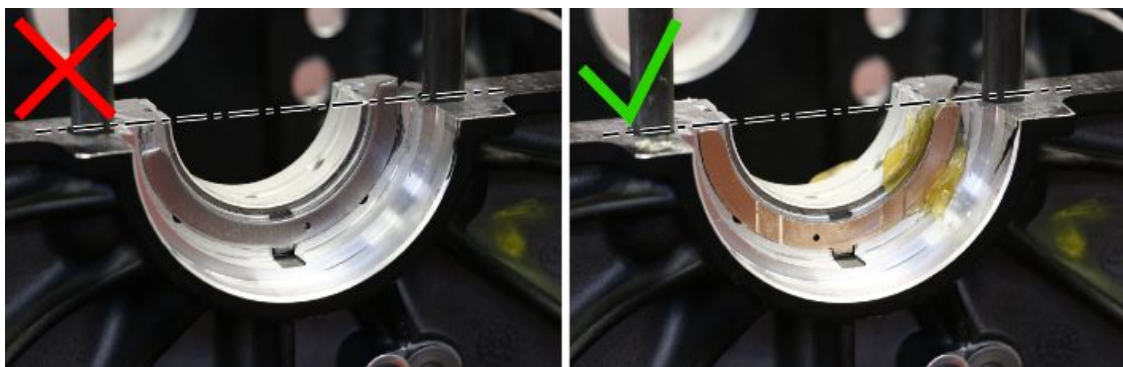

- Insert the seal ring (after lubricating it) on the crankshaft and the assembly onto the engine crankcase making sure that the connecting rods locate correctly into their seats.



- Smear the crankcases mating faces with the threebond

- Grasp the crankshaft assembly with the upper crankcase keeping the two components together, rotate them and lay them on the lower crankcase.



- Insert and screw the four long nuts and the six external nuts together with washers..
- Tighten all nuts to the prescribed torque proceeding with the cross order

Removing

- Remove the timing system complete with oil pump gear
- Using a hairdryer, heat the fixing base of the three oil pump screws.



- Remove the three fixing screws of the oil pump.

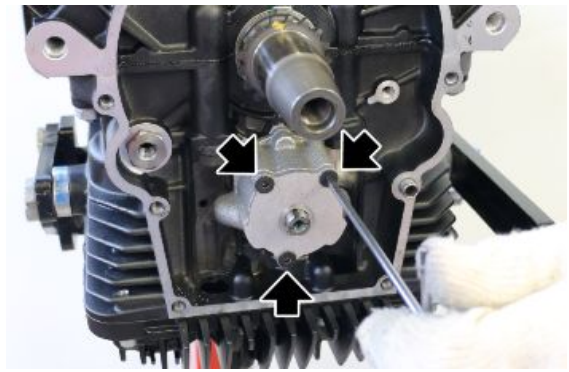

- Remove the complete pump from the crankcase.



- Remove the cover (1) from the pump (2).

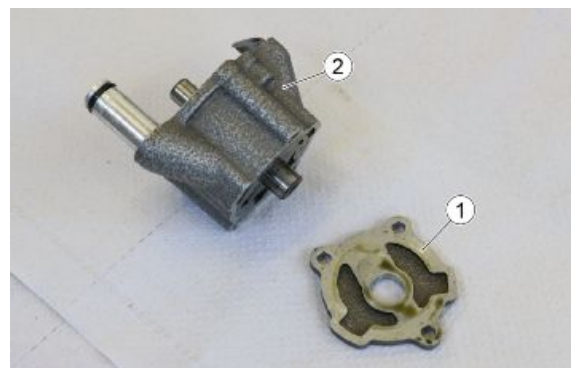

- Working on the oil pump gear side, remove the external rotor (3).



- Remove the internal rotor (4).



- Remove the safety pin (5) from the pump drive shaft.



- Working from the opposite side of the oil pump, extract the pump drive shaft (6) removing the internal rotor (7) and the external rotor (8).



Inspection

OIL PUMP BODY

Check that the faces and inner seats of the oil pump body are not scored, damaged or dented.

Pump body specifications:

OIL PUMP BODY

| Description | Values |
|---|-----------------------|
| External rotors seat diameter (MAXIMUM WEAR VALUE) | 40.675 mm (1.6014 in) |
| Diameter hole for pump drive shaft (MAXIMUM WEAR VALUE) | 15.995 mm (0.6297 in) |

EXTERNAL ROTORS

Check that the inner and outer surfaces and the flat faces are not scored, damaged or dented; if they are, replace both rotors of the side in question.

Data of the external rotors:

EXTERNAL ROTOR (ROTOR SIDE)

| Description | Values |
|--|----------------------|
| External diameter (WEAR LIMIT VALUE) | 40.54 mm (1.5961 in) |
| Internal diameter (MAXIMUM WEAR VALUE) | 24.23 mm (0.9539 in) |
| Thickness of seat (MAXIMUM WEAR VALUE) | 12.07 mm (0.4752 in) |

EXTERNAL ROTOR (CRANKCASE SIDE)

| Description | Values |
|--|----------------------|
| External diameter (WEAR LIMIT VALUE) | 40.54 mm (1.5961 in) |
| Internal diameter (MAXIMUM WEAR VALUE) | 24.23 mm (0.9539 in) |
| Thickness of seat (MAXIMUM WEAR VALUE) | 14.07 mm (0.5539 in) |

INTERNAL ROTOR

Check that the inner and outer surfaces and the flat faces are not scored, damaged or dented; if they are, replace both rotors of the side in question.

Data of the internal rotors:

INTERNAL ROTOR (ROTOR SIDE)

| Description | Values |
|--|-----------------------|
| External diameter (MAXIMUM WEAR VALUE) | 29.749 mm (0.1712 in) |
| Internal diameter (MAXIMUM WEAR VALUE) | 12.018 mm (0.4731 in) |
| Thickness (MINIMUM WEAR VALUE) | 11.97 mm (0.4713 in) |

INTERNAL ROTOR (CRANKCASE SIDE)

| Description | Values |
|--|-----------------------|
| External diameter (MAXIMUM WEAR VALUE) | 29.749 mm (0.1712 in) |
| Internal diameter (MAXIMUM WEAR VALUE) | 12.018 mm (0.4731 in) |
| Thickness (MINIMUM WEAR VALUE) | 13.97 mm (0.5500 in) |

OIL PUMP DRIVE SHAFT

Check shaft and thread for damage; check the keyway for burrs and make sure the head the runs in the rotor is not damaged; replace the shaft if needed.

Shaft specifications:

OIL PUMP DRIVE SHAFT

| Description | Values |
|--|-----------------------|
| Diameter for pump body seat (MINIMUM WEAR VALUE) | 11.989 mm (0.4720 in) |
| Diameter seat for roller bearings (MINIMUM WEAR VALUE) | 9.991 mm (0.3933 in) |

Installing

- Working from the rear side of the oil pump, insert the pump drive shaft (1) the internal rotor (2) and the external rotor (3).



- Working from the front of the oil pump, insert the internal rotor retaining pin (4).



- Insert the internal rotor (5) paying attention that the pin enters the machining seat.



- Insert the external rotor (6) paying attention to the punch mark that must be facing outwards.



- After inserting the cover, position the complete oil pump in place.



- Insert the three oil pump retaining screws and tighten them to the pre-defined tightening torque.

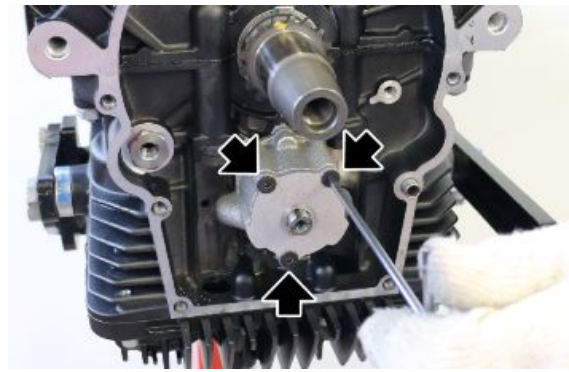

Oil sump

Removing the oil sump

- Remove the engine oil filter fixing screw



- Remove the engine oil filter



- -Remove the 14 fastening screws of the oil sump



- Remove the oil sump



- Remove the gasket



- Remove the rose pipe



- Remove the cap and the relative copper gasket

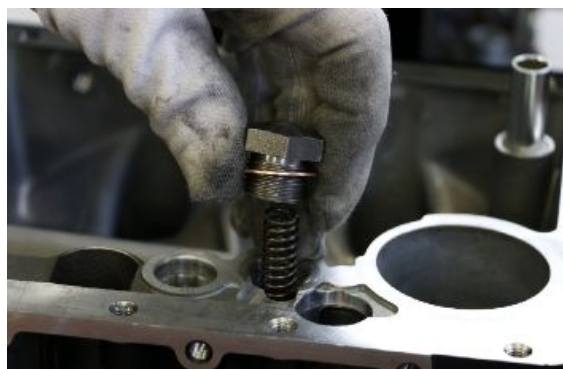

- Remove the spring



- Remove the overpressure valve



Refitting the oil sump

- Install the overpressure valve in the engine crankcase



- Insert the spring and afterwards the cap provided with a new copper gasket, tighten it to the prescribed torque



- Insert the rose pipe



- Place the gasket and insert the oil sump cover



- Insert and tighten the 14 fastening screws of the oil sump to the prescribed torque



- Insert the engine oil filter together with the cover



- Insert and tighten the locking screw of the engine oil filter to the prescribed torque



C

Chain: 56

Chain tensioner: 56

Clutch: 26, 27, 38, 40, 41

Crankcase: 72–74, 77

Crankshaft: 72, 74

Cylinder: 46, 51, 62, 63, 66, 68

D

Desmodromic drum: 27

F

Forks: 28

H

Head cover: 45, 72

O

Oil sump: 83, 85

P

Pistons:

Primary shaft: 16

S

Secondary shaft: 20

Starter motor: 37