

## **MOTO GUZZI WOULD LIKE TO THANK YOU**

for choosing one of its products. We have compiled this booklet to provide a comprehensive overview of your vehicle's quality features. Please read it carefully before riding the vehicle for the first time. It contains information, tips and precautions for using your vehicle. It also describes features, details and devices to assure you that you have made the right choice. We believe that if you follow our suggestions, you will soon get to know your new vehicle well and that it will continue to give you satisfactory service for many years to come. This booklet forms an integral part of the vehicle; should the vehicle be sold, it must be transferred to the new owner.

# **V85 TT - V85 TT Travel E5**



The instructions in this manual have been prepared to offer mainly a simple and clear guide to its use; it also describes routine maintenance procedures and regular checks that should be carried out on the vehicle at an **authorised Moto Guzzi Dealer or Workshop**. The booklet also contains instructions for simple repairs. Any operations not specifically described in this booklet require the use of special tools and/or particular technical knowledge; for these operations, please take your vehicle to an **authorised Moto Guzzi Dealer or Workshop**.



### **Personal safety**

Failure to completely observe these instructions will result in serious risk of personal injury.



### **Safeguarding the environment**

Sections marked with this symbol indicate the correct use of the vehicle to prevent damaging the environment.



### **Vehicle intactness**

The incomplete or non-observance of these regulations leads to the risk of serious damage to the vehicle and sometimes even the invalidity of the guarantee

*The symbols illustrated above are very important. They are used to highlight parts of the booklet that should be read with particular care. The different symbols are used to make each topic in the manual simple and quick to locate. Before starting the engine, read this booklet thoroughly and the "SAFE RIDING" section in particular. Your safety as well as other's does not only depend on the quickness of your reflexes and agility, but also on how well you know your vehicle, the state of maintenance of the vehicle itself and your knowledge of the rules for SAFE RIDING. For your safety, get to know your vehicle well so as to safely ride and master it in road traffic IMPORTANT This booklet is an integral part of the vehicle, and must be handed to the new owner in the event of sale.*



# INDEX

<b>GENERAL RULES</b> .....	7	MGCT system(Moto Guzzi Controllo Trazione).....	79
Carbon monoxide.....	8	Immobilizer system operation.....	82
Fuel.....	8	Opening the saddle.....	84
Hot components.....	9	USB Port.....	85
Warning lights.....	9	Identification.....	86
Used engine oil and gearbox oil.....	10	Adjusting the windscreen.....	87
Brake fluid.....	11	<b>USE</b> .....	89
Battery hydrogen gas and electrolyte.....	11	Checks.....	90
Precautions general advice.....	12	Refuelling.....	92
<b>VEHICLE</b> .....	15	Rear shock absorbers adjustment.....	95
Arrangement of the main components.....	16	Rear shock absorbers setting.....	96
Dashboard.....	19	Front fork adjustment.....	98
Instrument panel.....	21	Front fork setting.....	99
Light unit.....	22	Justering af greb til forbremse.....	100
Digital lcd display.....	23	Rear brake pedal adjustment.....	101
Alarms.....	28	Clutch lever adjustment.....	101
Mapping selection.....	32	Running in.....	102
Control buttons.....	34	Starting up the engine.....	103
Advanced functions.....	35	Moving off / riding.....	106
Ignition switch.....	65	Stopping the engine.....	110
Locking the steering wheel.....	66	Parking.....	111
Horn button.....	67	Catalytic silencer.....	112
Switch direction indicators.....	68	Stand.....	113
High/low beam selector.....	69	Suggestion to prevent theft.....	114
Passing button.....	69	Safe driving.....	115
Daytime/night lights switch.....	70	Basic safety rules.....	116
Heated handgrip control.....	70	Load.....	120
Flasher button.....	71	<b>MAINTENANCE</b> .....	125
Start-up button.....	72	Foreword.....	126
Engine stop switch.....	72	Engine oil level check.....	126
Button Cruise Control.....	73	Engine oil top-up.....	128
Selector MODE.....	75	Engine oil change.....	128
System ABS.....	75	Engine oil filter replacement.....	128

Bevel gear pair oil level.....	129
Gearbox oil level.....	129
Tyres.....	129
Spark plug dismantlement.....	131
Removing the air filter.....	131
Checking the brake oil level.....	132
Braking system fluid top up.....	133
Battery removal.....	133
Checking the electrolyte level.....	135
Charging the battery.....	136
Long periods of inactivity.....	136
Fuses.....	137
Front light group.....	140
Headlight adjustment.....	141
Front direction indicators.....	142
Additional light.....	143
Bulb replacement.....	143
Rear optical unit.....	144
Rear turn indicators.....	144
Rear-view mirrors.....	144
Front and rear disc brake.....	146
Periods of inactivity.....	147
Cleaning the vehicle.....	149
Transport.....	154
<b>TECHNICAL DATA.....</b>	<b>157</b>
<b>PROGRAMMED MAINTENANCE.....</b>	<b>167</b>
Scheduled maintenance table.....	168
Recommended products.....	171

# V85 TT - V85 TT Travel E5



**Chap. 01**  
**General rules**

## Carbon monoxide

### CAUTION



**EXHAUST EMISSIONS CONTAIN CARBON MONOXIDE, A POISONOUS GAS WHICH CAN CAUSE LOSS OF CONSCIOUSNESS AND EVEN DEATH.**

### CAUTION



**CARBON MONOXIDE IS ODOURLESS AND COLOURLESS, THEREFORE IT CANNOT BE DETECTED BY SMELL, SIGHT OR OTHER SENSES. DO NOT BREATHE IN EXHAUST FUMES UNDER ANY CIRCUMSTANCES.**

## Fuel

### CAUTION



**FUEL USED TO DRIVE EXPLOSION ENGINES IS HIGHLY INFLAMMABLE AND CAN BECOME EXPLOSIVE UNDER SPECIFIC CONDITIONS. IT IS THEREFORE RECOMMENDED TO CARRY OUT REFUELLING AND MAINTENANCE PROCEDURES IN A VENTILATED AREA WITH THE ENGINE SWITCHED OFF. DO NOT SMOKE DURING REFUELLING OR NEAR FUEL VAPOUR. AVOID ANY CONTACT WITH NAKED FLAME, SPARKS OR OTHER HEAT SOURCES WHICH MAY CAUSE IGNITION OR EXPLOSION.**

**DO NOT ALLOW FUEL TO DISPERSE INTO THE ENVIRONMENT.**



**KEEP OUT OF THE REACH OF CHILDREN.**



**IF THE VEHICLE FALLS OR IS ON A STEEP INCLINE FUEL CAN LEAK.**

### **Hot components**

The engine and the exhaust system components get very hot and remain in this condition for a certain time interval after the engine has been switched off. Before handling these components, make sure that you are wearing insulating gloves or wait until the engine and the exhaust system have cooled down.

### **Warning lights**



**IF THE ALARM WARNING LAMPS ILLUMINATE DURING THE NORMAL ENGINE OPERATION, THIS MEANS THAT THE ELECTRONIC CONTROL UNIT HAS FOUND AN ABNORMALITY.**



**IF THE GENERAL ALARM WARNING LAMP FLASHES DURING THE NORMAL ENGINE OPERATION, THIS MEANS THAT THE OIL PRESSURE IN THE CIRCUIT IS INSUFFICIENT.**

**IN THIS CASE THE ENGINE MUST BE SHUT OFF IMMEDIATELY IN ORDER TO PREVENT POSSIBLE DAMAGE.**



**PERFORM THE MOTOR OIL LEVEL CHECK. IF THE INSUFFICIENT MOTOR OIL PRESSURE LIGHT REMAINS DESPITE THE ABOVE PROCEDURE BEING PERFORMED CORRECTLY, CONTACT AN AUTHORIZED Moto Guzzi Dealer TO HAVE THE SYSTEM CHECKED.**

## **Used engine oil and gearbox oil**

### **CAUTION**



**WHEN CARRYING OUT MAINTENANCE OPERATIONS, IT IS ADVISABLE TO WEAR PROTECTIVE IMPERMEABLE GLOVES.**

**THE ENGINE OR GEARBOX OIL MAY CAUSE SERIOUS INJURIES TO THE SKIN IF HANDLED FOR PROLONGED PERIODS OF TIME AND ON A REGULAR BASIS.**

**WASH YOUR HANDS CAREFULLY AFTER HANDLING OIL.**

**HAND THE OIL OVER TO OR HAVE IT COLLECTED BY THE NEAREST USED OIL RECYCLING COMPANY OR THE SUPPLIER.**

**DO NOT DISPOSE OF OIL IN THE ENVIRONMENT**

**KEEP OUT OF THE REACH OF CHILDREN.**

## Brake fluid



**BRAKE FLUID MAY BE HARMFUL TO PAINTWORK, PLASTIC AND RUBBER. WHEN SERVICING THE BRAKING SYSTEM PROTECT THESE COMPONENTS WITH A CLEAN CLOTH. ALWAYS WEAR PROTECTIVE GOGGLES WHEN SERVICING THESE SYSTEMS. BRAKE FLUID IS EXTREMELY HARMFUL TO THE EYES. IN THE EVENT OF ACCIDENTAL CONTACT WITH THE EYES, RINSE THEM IMMEDIATELY WITH PLENTY OF COLD, CLEAN WATER AND SEEK MEDICAL ADVICE.**

**KEEP OUT OF THE REACH OF CHILDREN.**

## Battery hydrogen gas and electrolyte

### CAUTION



**THE BATTERY ELECTROLYTE IS TOXIC, CORROSIVE AND AS IT CONTAINS SULPHURIC ACID, IT CAN CAUSE BURNS WHEN IN CONTACT WITH THE SKIN. WHEN HANDLING BATTERY ELECTROLYTE, WEAR TIGHT-FITTING GLOVES AND PROTECTIVE APPAREL. IN THE EVENT OF SKIN CONTACT WITH THE ELECTROLYTIC FLUID, RINSE WELL WITH PLENTY OF CLEAN WATER. IT IS PARTICULARLY IMPORTANT TO PROTECT YOUR EYES BECAUSE EVEN TINY AMOUNTS OF BATTERY ACID MAY CAUSE BLINDNESS. SEEK SPECIALISED MEDICAL ATTENTION IMMEDIATELY IN THE EVENT OF CONTACT WITH THE EYES. THE BATTERY RELEASES EXPLOSIVE GASES; KEEP IT AWAY FROM FLAMES, SPARKS, CIGARETTES OR ANY OTHER HEAT SOURCES. ENSURE ADEQUATE VENTILATION WHEN SERVICING OR RECHARGING THE BATTERY.**

**KEEP OUT OF THE REACH OF CHILDREN.**

**BATTERY LIQUID IS CORROSIVE. DO NOT POUR IT OR SPILL IT, PARTICULARLY ON PLASTIC COMPONENTS. ENSURE THAT THE ELECTROLYTIC ACID IS COMPATIBLE WITH THE BATTERY TO BE ACTIVATED.**

## **Precautions general advice**

### **DANGER OF OVERHEATING**

- WHEN THE VEHICLE IS STATIONARY, DO NOT KEEP THE ENGINE RUNNING MORE THAN NECESSARY, THIS MAY CAUSE EXCESSIVE OVERHEATING. IN EXTREME CASES, RISK OF FIRE. WHEN THE VEHICLE IS STATIONARY, DO NOT UNNECESSARILY RUN THE ENGINE.
- START IMMEDIATELY AFTER IGNITION, MAKING SURE TO RIDE A SHORT INITIAL DISTANCE AT LOW RPM.
- AFTER USE, AS SOON AS PARKED, THE ENGINE MUST BE IMMEDIATELY TURNED OFF.
- AFTER USE, DO NOT PLACE OBJECTS IN CONTACT WITH THE VEHICLE, WHEN IT IS STILL HOT, AS THEY COULD IGNITE (E.G. PROTECTIVE FABRICS, JACKET, ETC.).

### **HANDLING**

- DO NOT ALTER ANY PART OF THE MOTORCYCLE (FOR EXAMPLE, ENGINE CONTROL UNIT, THROTTLE VALVES, CLUTCH, EXHAUST SYSTEM, ETC.). THIS MAY DAMAGE THE COMPONENTS INVOLVED, MAY CAUSE MALFUNCTION OF THE SAFETY RELATED FUNCTIONS AND RENDER THE WARRANTY VOID.

### **RISK OF BURNING**

IN CASE OF ENGINE OR EXHAUST SYSTEM OVERHEATING WHILE DRIVING, PAY PARTICULAR ATTENTION TO THE FOLLOWING:

- RISK OF BURNING.

- AFTER STOPPING THE VEHICLE, MAKE SURE THAT NO PERSON OR OBJECT TOUCHES THE ENGINE AND THE EXHAUST SYSTEM.

Unless otherwise specified in this Use and Maintenance Manual, do not remove any mechanical or electrical component.

**CAUTION**

**SOME CONNECTORS IN THE VEHICLE MAY BE ACCIDENTALLY SWAPPED AND MAY COMPROMISE NORMAL VEHICLE OPERATION IF INCORRECTLY INSTALLED.**



# V85 TT - V85 TT Travel E5



**Chap. 02**  
**Vehicle**

## Arrangement of the main components (02\_01, 02\_02)

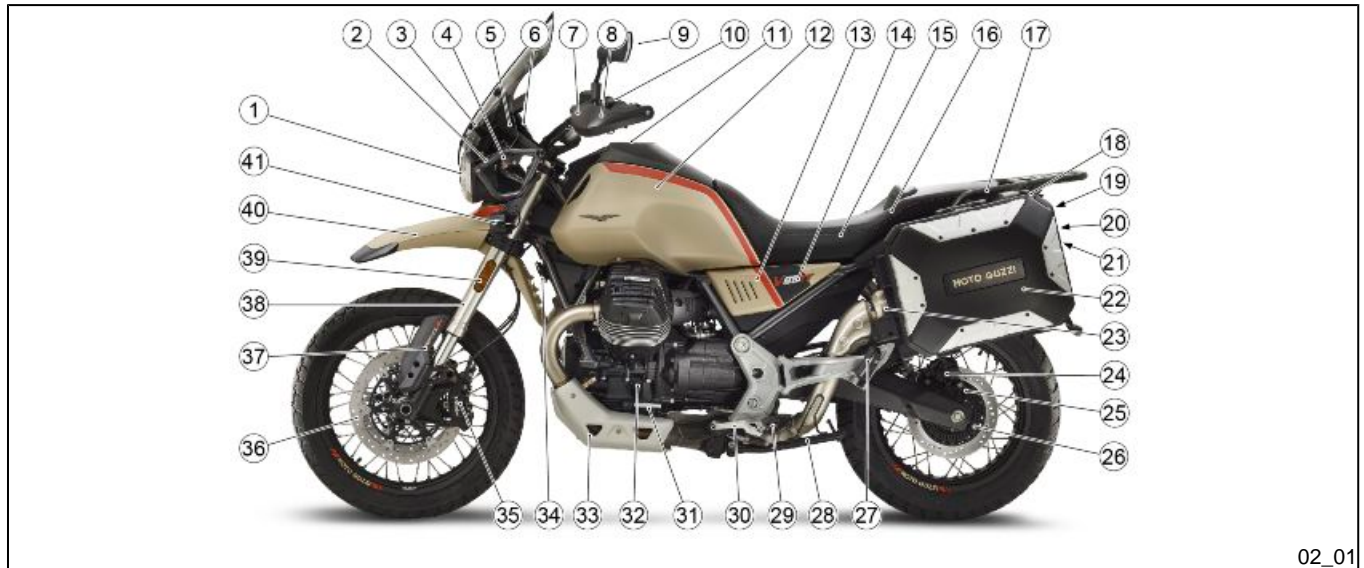

02\_01





02\_02

**Key:**

1. Headlamp
2. Headlight support frame
3. Adjustable windshield
4. Front left turn indicator
5. USB port
6. Instrument panel
7. Left hand guard
8. Clutch lever
9. Left rear-view mirror
10. Left light switch
11. Fuel tank cap
12. Fuel tank
13. Air filter

14. Left side fairing
15. Main fuses
16. Two-seater saddle
17. Accessories support frame
18. Taillight
19. Seat lock
20. Licence plate light
21. Rear left turn indicator
22. Left case (where required)
23. Silencer
24. Rear brake calliper
25. Rear tone wheel sensor
26. Rear tone wheel
27. Passenger left footrest
28. Side stand
29. Left rider footrest
30. Gear shift lever
31. Engine oil level inspection port
32. Engine oil filler cap
33. Sump guard
34. Horn
35. Front left brake calliper
36. Left front brake disc
37. Left fork guard
38. Left fork
39. Left hand reflector
40. Front mudguard
41. Left fog light (where required)
42. Rear right turn indicator
43. Secondary fuses
44. Right side fairing
45. Accelerator control
46. Right light switch
47. Right rear-view mirror
48. Front brake lever
49. Right hand guard
50. Front right turn indicator
51. Right fog light (if applicable)

52. Right hand reflector
53. Right fork (adjustable)
54. Front tone wheel
55. Front tone wheel sensor
56. Front right brake calliper
57. Rear brake oil tank
58. Rear brake lever
59. Right rider footrest
60. Rear shock absorber (adjustable)
61. Right passenger footrest
62. Right case (where applicable)

## **Dashboard (02\_03)**

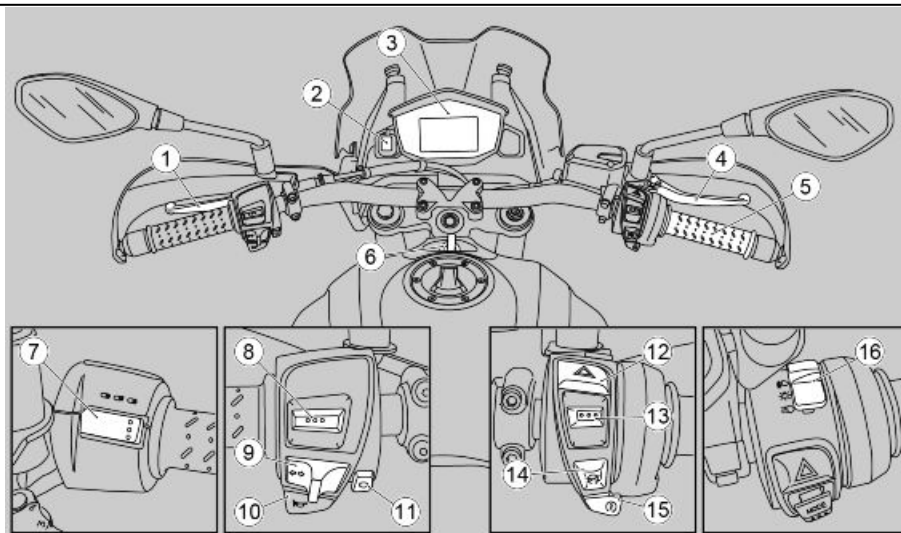

02\_03

**Key:**

1. Clutch control lever
2. USB port
3. Instruments and gauges
4. Front brake lever
5. Throttle grip
6. Ignition switch /steering lock
7. High beam/passing light switch
8. Cruise control button
9. Turn signal switch
10. Horn button
11. Heated hand grips
12. Turn indicator switch
13. MODE selector switch

14. Motor cut-out switch
15. Starter button
16. Daytime lights/taillights/additional headlamps switch



## Instrument panel (02\_04, 02\_05)

### Key:

1. Multifunctional digital display box.
2. Indicator lights.

The instrument panel has an immobilizer system which prevents start-up if the system does not identify a key which has been stored previously.

The vehicle is supplied with two keys already programmed. The instrument panel accepts a maximum of four keys at the same time: contact an Authorised **Moto Guzzi** dealer to enable these keys or to disable a key that has been lost. When the vehicle is delivered and approximately ten seconds after the key is turned ON, the instrument panel remembers a personal five-digit code that has been entered.

To enter the personal code, see the "Advanced functions" chapter

The far left of the display shows a value when using the MODE selector that varies from 0 to 9. Press the centre of the MODE selector to confirm each of the five figures. Once confirmed, the display shows the code in a fixed manner, this is so the user can check the code that has been entered. To remove the screen showing the code that has been entered, carry out a KEY OFF- KEY ON cycle. In the future you can always change the last code entered. This request is no longer displayed once the personal code is entered.

It is important to remember the personal code because:

- the vehicle can be started if the immobilizer system is faulty
- the instrument panel need not be replaced should the ignition switch be changed
- new keys can be programmed

#### NOTE

IF THE PERSONA CODE IS NOT MEMORISED AND THE VEHICLE IS USED, THE MESSAGE DISAPPEARS AFTER 10 SECONDS BUT REAPPEARS WITH EACH KEY ON.

#### NOTE

THE FACTORY SET CODE IS COMPOSED OF FIVE ZEROES.

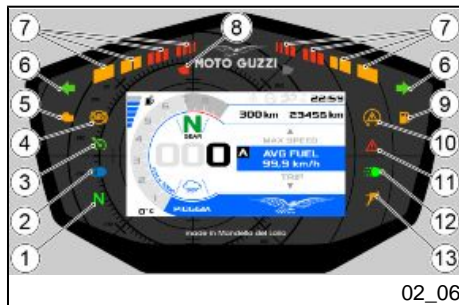

### Light unit (02\_06)

Key:

1. Neutral indicator light, green.
2. High beam indicator light, blue.
3. Cruise control indicator light, green.
4. ABS indicator light, orange.
5. MI indicator light, orange.
6. Turn indicator light, green.
7. Overspeed threshold/shift light indicator light, white/orange/red. MGCT indicator lights, only orange
8. Immobilizer indicator light, red
9. Low fuel indicator light, orange.
10. MGCT indicator light, orange.
11. General warning light, red
12. Daytime light indicator light, green.
13. Side stand indicator light, orange.

## Digital lcd display (02\_07, 02\_08, 02\_09, 02\_10, 02\_11, 02\_12, 02\_13)

### NOTE

THE DASHBOARD IS PROVIDED WITH A TWILIGHT SENSOR THAT, BASED ON THE AMBIENT LIGHTING, CAN PASS FROM DAYLIGHT MODE TO NIGHT TIME MODE, CHANGING THE COLOUR OF THE BACKGROUND WHEN "AUTO" (AUTOMATIC) MODE IS SET IN THE ADVANCED FUNCTIONS.

- Turning the ignition switch to 'KEY ON', the following illuminate on the dashboard for about two seconds:
  - A dynamic graphic presentation.
  - All indicator lights on.

Using the MODE selector it is possible to move between the various information available in the "trip journal".

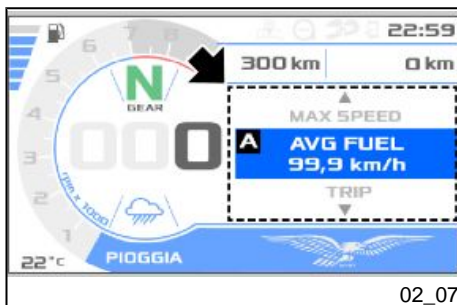

The following information can be seen in the digital display





- 8) Remaining km/mi of the journey.
- 9) Presence of underpowered map indicator (35kW).
- 10) Clock (can be displayed both in 24H mode, as well as 12H mode without AM / PM indicated).
- 11) Odometer.
- 12) Journal of the trip computer.
- 13) Info Pop-up.
- 14) Cruise control.
- 15) ABS system indication on front wheel only in "OFF ROAD" mode only.
- 16) Riding mode selected.
- 17) Ambient temperature (Can be displayed in C° or in F°).
- 18) Ice warning indicator (visible from -15 C° (5 F °) to +3 C° (37.4 F°)) / Battery warning indicator (voltage between the poles too low).

**Where the MGMP ECU is present:**

- 19) GPS/Navigator (where active)
- 20) Data transmission with smartphone.
- 21) Rider/passenger intercom.
- 22) Audio transmission with smartphone for calling, sending vocal commands and playing music.



### MAINTENANCE ICON

When a maintenance interval threshold is exceeded, an icon with a spanner is shown.

This indicator may be reset once the scheduled service has been completed by an **authorised Moto Guzzi Dealer or service centre.**

### ICE WARNING

When the outdoor temperature is less than or equal to 3 °C (37.4 °F), until at least -15 °C (5 °F) the ice alarm symbol appears on the display, alternating with the battery alarm (if active ).

### NOTE

**THE FOLLOWING INDICATION IS NOT VISIBLE IN THE NAVIGATION SCREEN.**

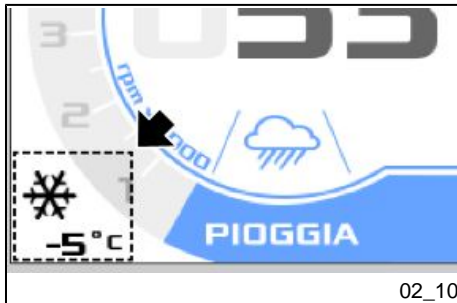

### ICE HAZARD WARNING

At temperatures of 3 °C (37.4 °F) and below, down to a minimum detected temperature of -15 °C (5 °F), the ice hazard warning icon is shown on the display. If the ice hazard icon and the low battery voltage icon are active simultaneously, they are displayed in alternation.

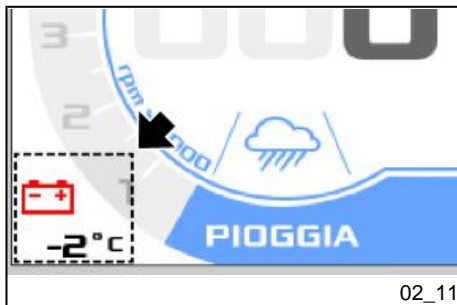

02\_11

### BATTERY WARNING

The lighting of the battery symbol, visible in the lower left corner of the digital display, indicates a problem in the battery charging system, alternating with the ice alarm (if active).

#### NOTE

**THE FOLLOWING INDICATION IS NOT VISIBLE IN THE NAVIGATION SCREEN.**

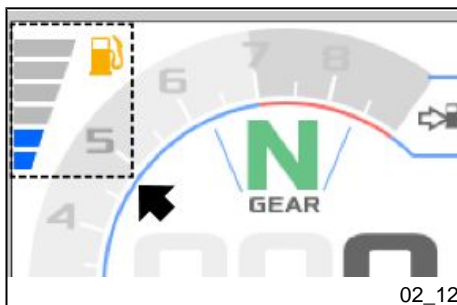

02\_12

### FUEL LEVEL

The fuel level in the tank is represented on the display by a number of bars.

When the fuel level drops below the third mark, the symbol in the digital display turns orange and the dedicated warning light comes on.

#### NOTE

**IF WHEN THE KEY IS INSERTED THE FUEL RESERVE LIGHT FLASHES, THIS MEANS THAT THE SENSOR IS BROKEN.**

**IF THE FUEL RESERVE SENSOR DOES NOT WORK PROPERLY DURING WHEN RUNNING, THE LEVEL REFERENCE BARS WILL NOT BE VISIBLE ON THE DIGITAL DISPLAY, THEREFORE GO TO AN Official Moto Guzzi dealer.**

#### NOTE

**THE INDICATED FUEL LEVEL MAY VARY AND NOT BE DISPLAYED ACCURATELY IF THE MOTORCYCLE IS INCLINED (E.G. WHEN THE MOTORCYCLE IS PLACED ON THE SIDE STAND, OR IF VEHICLE IS RIDDEN ON LONG STRETCHES OF UPHILL OR DOWNHILL ROAD).**



02\_13

With the key set to "KEY OFF" the general alarm warning light flashes to indicate activation of the locking system. To reduce battery consumption the light stops flashing after about 48 hours.



02\_14

## Alarms (02\_14, 02\_15, 02\_16, 02\_17, 02\_18, 02\_19, 02\_20, 02\_21)

In the event of a fault, the digital display will show the cause.

Contact an Authorised **Moto Guzzi** Dealer as soon as possible.

### SERVICE ALARM

In case of failure found in the instrument panel or in the electronic control unit, the instrument panel signals the failure by displaying the word SERVICE and the red general warning light turns on.



02\_15

If there is an immobilizer failure at ignition, the instrument panel requests you to enter a user code. If the code is entered correctly, the instrument panel signals the failure by displaying the word SERVICE and the red general warning light turns on.

### URGENT SERVICE ALARM

A serious failure is signalled by a fast flashing (two flashes per second) of the general warning light and by the words URGENT SERVICE on the digital display. Contact an Authorised **Moto Guzzi** Dealer as soon as possible. In these cases, the ECU activates a safety procedure limiting vehicle performance in order to allow the rider to go to an Authorised **Moto Guzzi** Dealer at a reduced speed. Depending on the type of failure, performance can be limited in three ways: a) by reducing the maximum torque pro-

duced; b) by keeping the engine at idle speed but slightly accelerated (during this operation, the throttle control is disabled); c) the engine rpm is steady at around 3000 rpm; Under these conditions the throttle control provides limited management of the torque.

#### NOTE

**WHEN THE "URGENT SERVICE" ERROR APPEARS ON THE DIGITAL DISPLAY, THE FOUR ARROWS FLASH FOR 30 SEC. TO WARN THE VEHICLES BEHIND OF A POTENTIALLY HAZARDOUS SITUATION UNTIL THE TURN INDICATOR IS ACTIVATED TO ALLOW THE DRIVER TO PULL OVER.**

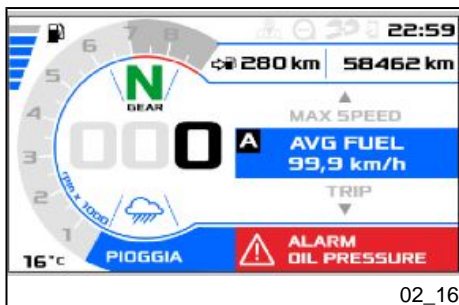

#### Oil failure

If a fault is detected with the oil pressure, the digital display shows "ALARM OIL PRESSURE".

#### CAUTION

**THE SIGNAL IS ACCOMPANIED BY THE RED GENERAL WARNING LIGHT FLASHING.**



**STOP THE VEHICLE AND CONTACT AN Approved Moto Guzzi dealer AS SOON AS POSSIBLE.**

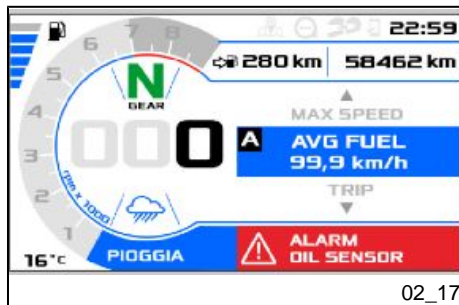

If a fault is detected with the oil pressure sensor, the digital display shows "ALARM OIL SENSOR".

#### CAUTION

THE SIGNAL IS ACCOMPANIED BY THE RED GENERAL WARNING LIGHT TURNING ON.

#### WARNING

TAKE YOUR VEHICLE TO AN Official Moto Guzzi Dealer AS SOON AS POSSIBLE.

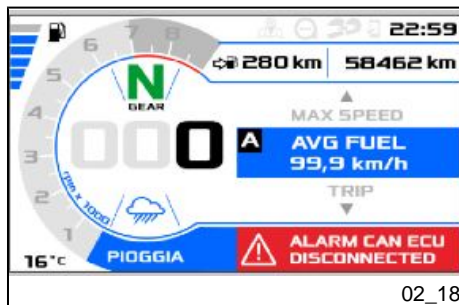

#### Electronic control unit disconnected alarm

If there is no connection, the instrument panel signals the fault by displaying "ALARM CAN ECU DISCONNECTED" and lighting up the general alarm red warning light.

#### NOTE

THE MESSAGE "ALARM CAN ECU DISCONNECTED" REMAINS ON THE DIGITAL DISPLAY AND THE HAZARD WARNING LIGHTS WILL CONTINUE TO FLASH (TO WARN OTHER ROAD USERS BEHIND THE VEHICLE OF POTENTIAL DANGER) UNTIL THE RIDER ACTIVATES THE RIGHT HAND TURN SIGNAL TO INDICATE THAT THEY ARE ABOUT TO PULL OVER AND STOP.

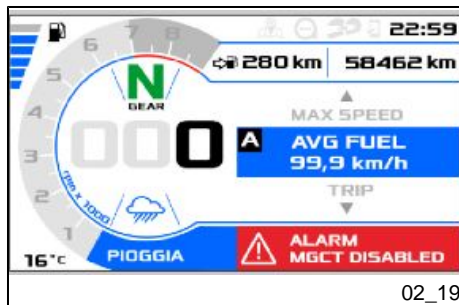

#### MGCT alarm disabled

the alarm disabling the MGCT system is activated when there is a problem that can cause the system itself to be disabled.

#### WARNING

DRIVE CAREFULLY AND CONTACT AN Official Moto Guzzi Dealer AS SOON AS POSSIBLE.

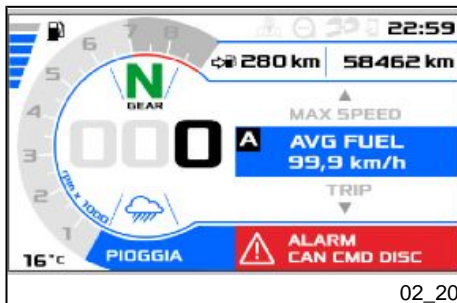

### CAN line disconnection from light switch alarm

The alarm disconnecting the interface line of the LH light switch is activated when there is a problem that can cause the light switch itself to be disabled.

When this error occurs, the arrows, cruise control and heated hand grips (if present) do not work.

#### CAUTION

**THE SIGNAL IS ACCOMPANIED BY THE RED GENERAL WARNING LIGHT TURNING ON.**

#### WARNING

**DRIVE CAREFULLY AND CONTACT AN Official Moto Guzzi Dealer AS SOON AS POSSIBLE.**

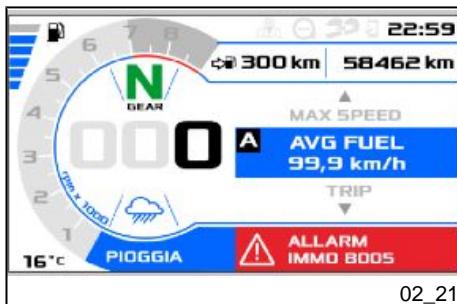

### Immobilizer alarms

For the immobilizer alarms, refer to the "Operating of the immobilizer system" paragraph. The error code may vary.

If an alarm is generated, you must enter the user code to start the vehicle.

#### CAUTION

**THE SIGNAL IS ACCOMPANIED BY THE RED GENERAL WARNING LIGHT TURNING ON.**

#### WARNING

**DRIVE CAREFULLY AND CONTACT AN Official Moto Guzzi Dealer AS SOON AS POSSIBLE.**

## Mapping selection (02\_22, 02\_23, 02\_24)

### CAUTION

IN NAVIGATOR MODE THE DISPLAY OF THE ACTIVE "RIDING MODE" WILL NOT BE VISIBLE.

The engine control unit has 5 different selectable "riding modes" for managing the electronic accelerator, displayed as follows in the lower left part of the digital display:

- OFF ROAD (OFF ROAD)
- SPORT (SPORT)
- STRADA (ROAD)
- PIOGGIA (RAIN)
- CUSTOM (CUSTOM)

The **ROAD** mode is designed for a touristic use of the vehicle.

The **SPORT** mode is designed for a more dynamic use of the vehicle.

The **CUSTOM** mode can be configured by the user, as shown in the "ADVANCED FUNCTIONS" section.



The **OFF ROAD** mode is not suitable for road use. It is designed for use on variable low-grip surfaces.

### CAUTION

THE USE OF THIS MODE IT IS RECOMMENDED ON LOW-GRIP SURFACES. IT IS RECOMMENDED FOR OFF-ROAD USE.

THE TRACTION CONTROL IS LITTLE INVASIVE.

ONLY IN THIS MODE DOES THE ABS SYSTEM STAY ACTIVE EXCLUSIVELY FOR THE FRONT WHEEL AND THE DEDICATED SYMBOL APPEARS ON THE DISPLAY TO REMIND THE RIDER TO TAKE PARTICULAR CARE.





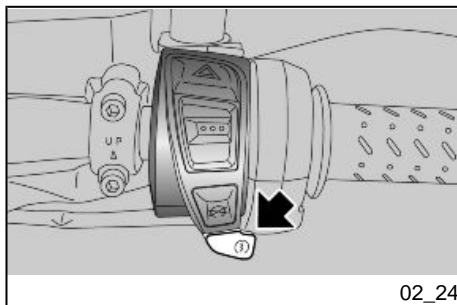

The **RAIN** mode is designed for use of the vehicle on wet surfaces or in conditions of poor grip. The system provides the torque smoothly to prevent loss of grip. In this mode, the vehicle performance is limited, and therefore, the maximum speed cannot be reached.

**EVEN IN THIS MODE, ALWAYS USE PARTICULAR CAUTION WHEN RIDING IN POOR GRIP CONDITIONS.**

Passing through the various riding modes is carried out using the starter button that, 3 seconds after the engine has started, acquires the function of "Riding mode selection button".

**CAUTION**

**THE RIDING MODE SELECTION PROCEDURE IS ACTIVE ONLY WITH THE ENGINE STARTED AND THE THROTTLE RELEASED. THIS PROCEDURE CAN ALSO BE CARRIED OUT WITH THE MOTORCYCLE MOVING AND THE THROTTLE RELEASED.**

**RIDING MODES MAY ALSO BE PRESELECTED WHILE THE THROTTLE IS OPEN. IN THIS CASE, THE NEW MODE IS ONLY EFFECTIVELY IMPLEMENTED WHEN THE THROTTLE IS CLOSED AGAIN. THE ICON FLASHES WHEN A NEW MODE IS PRESELECTED AND PENDING IMPLEMENTATION.**

To change the riding mode proceed as follows:

- By pressing the button for the first time, the symbol of the riding mode currently applied will be flashing.
- pressing the button again within 1.5 seconds from the first time, the next riding mode selected will be flashing. If the button is not pressed again within 1.5 seconds (which would select the next available riding mode), and the throttle grip is not used, the new riding mode is shown in a fixed manner on the display, indicating that the new riding mode selection has been implemented.

**CAUTION**

**IF THE THROTTLE IS OPENED WHILE THE NEW RIDING MODE IS SHOWN IN FLASHING MODE ON THE DISPLAY (I.E. MODE IS PRESELECTED ONLY AND PENDING IMPLEMENTATION BY THE ECU), THE PRESELECTED NEW RIDING**

**MODE WILL NOT BE EFFECTIVELY IMPLEMENTED UNTIL THE THROTTLE GRIP IS RELEASED.**

**IF A NEW RIDING MODE IS SELECTED WHILE THE THROTTLE IS OPEN, THE NEW RIDING MODE REQUESTED WILL BE SHOWN IN FLASHING MODE UNTIL THE THROTTLE GRIP IS RELEASED.**

## Control buttons (02\_25, 02\_26, 02\_27)

### CONTROL BUTTONS

- Push the "MODE" selector up or down to scroll and view the name given in the display in the trip log.
- Hold down the centre of the "MODE" selector to reset the data except for the "FUEL" function.

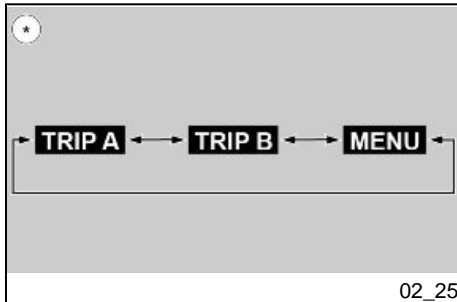

### Trip A and Trip B

Two trip logs are available (\*).

Hold down the centre of the "MODE" selector to display cyclically TRIP A, TRIP B and the MENU.

In both trip logs, briefly press the "MODE" selector up or down to display the following information (\*\*):

- (1) TRIP
- (2) FUEL
- (3) AVG FUEL
- (4) AVG SPEED
- (5) MAX SPEED
- (6) TIME

In all the functions, holding down the centre of the "MODE" selector clears the information stored in the active TRIP except for the "FUEL" function.

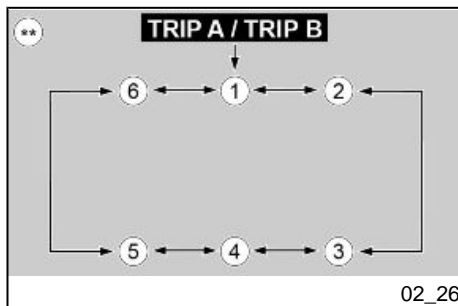

**Advanced functions (02\_27, 02\_28, 02\_29, 02\_30, 02\_31, 02\_32, 02\_33, 02\_34, 02\_35, 02\_36, 02\_37, 02\_38, 02\_39, 02\_40, 02\_41, 02\_42, 02\_43, 02\_44, 02\_45, 02\_46, 02\_47, 02\_48, 02\_49, 02\_50, 02\_51, 02\_52, 02\_53, 02\_54, 02\_55, 02\_56, 02\_57, 02\_58, 02\_59, 02\_60, 02\_61, 02\_62, 02\_63, 02\_64, 02\_65, 02\_66, 02\_67, 02\_68, 02\_69, 02\_70, 02\_71, 02\_72, 02\_73, 02\_74, 02\_75, 02\_76, 02\_77)**

The advanced functions consist of two entries: **MENU** and **CUSTOM MODE**. It is possible to scroll between the two entries by shortly pressing the MODE button in the middle.

### MENU

After having been selected, the configuration menu can be immediately accessed, with the vehicle stationary, by long pressing the MODE selector in the middle directly from the main screen.

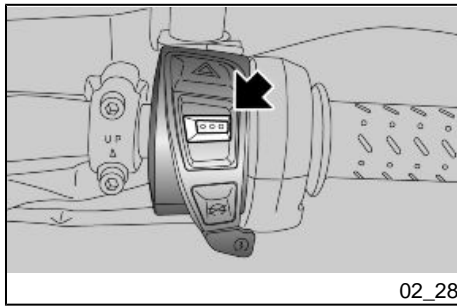

The flow diagram listed below shows the menu structure.

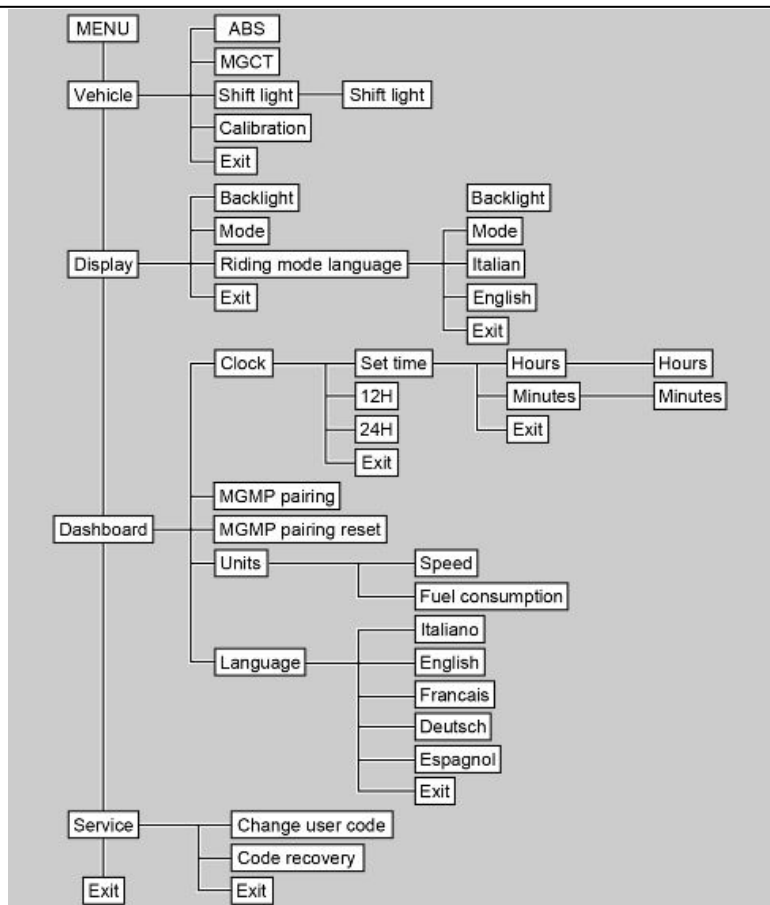

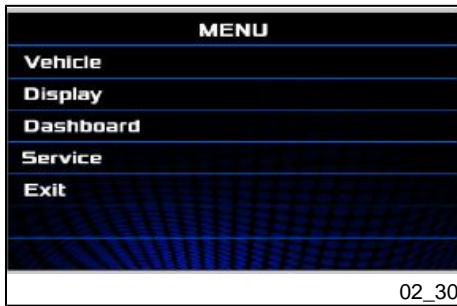

The menu is composed of the following entries:

- 1) Vehicle
- 2) Display
- 3) Dashboard (Dashboard)
- 4) Service (Service)
- 5) Exit (Exit)



### 1) Vehicle

The "Vehicle" menu consists of the following entries:

- 1.1) ABS
- 1.2) MGCT (Moto Guzzi Traction Control)
- 1.3) Shift light (Shift light)
- 1.4) Calibration (Calibration)
- 1.5) Exit (Exit)

The functions of the "Vehicle" menu are described in the following paragraphs.

To return to the main "MENU", select "Exit" on the menu and press the MODE selector briefly in the middle.

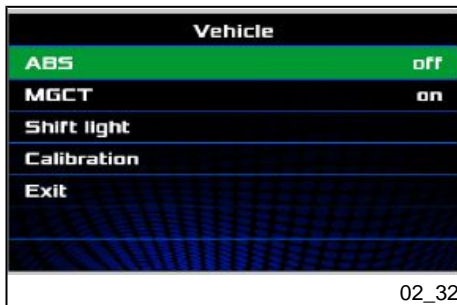

02\_32

### 1.1) ABS

This function allows you to disable the ABS system that is normally active "On".

Briefly pressing the MODE selector in the middle deactivates the function ("Off") and pressing it again reactivates it ("reactivate").

Disabling is possible only when the vehicle is in "OFF ROAD" mode. If the riding mode is changed, ABS reactivates.

To return to the "MENU", briefly press the MODE selector in the middle on "Exit"

#### CAUTION

**IT IS DISABLED ONLY TEMPORARILY, WHEN THE KEY IS INSERTED THE SYSTEM IS ALWAYS ACTIVE.**

#### CAUTION

**DISABLING IS POSSIBLE ONLY WHEN THE VEHICLE IS IN "OFF ROAD" MODE. IF THE RIDING MODE IS CHANGED, ABS REACTIVATES.**

**IF DISABLED, THE ABS INDICATOR LIGHT STAYS ON STEADY.**

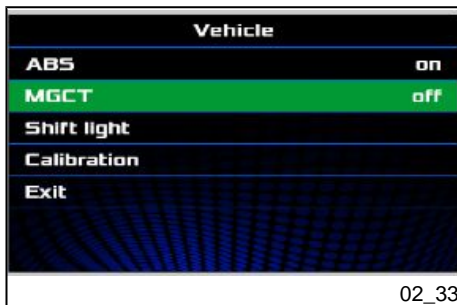

02\_33

### 1.2) MGCT (Moto Guzzi Traction Control)

This function allows to disable the MGCT system that is normally active "On".

Briefly pressing the MODE selector in the middle deactivates the function ("Off") and pressing it again reactivates it ("reactivate").

To return to the "MENU", briefly press the MODE selector in the middle on "Exit"

#### CAUTION

**IT IS DISABLED ONLY TEMPORARILY, WHEN THE KEY IS INSERTED THE SYSTEM IS ALWAYS ACTIVE.**



### 1.3) Shift light (Shift light)

This function allows you to set the rpm threshold that lights up the relative warning lights when exceeded.

Briefly pressing the MODE selector in the middle highlights the function in red and by moving it up or down it is possible to modify the threshold.

To exit the modification function, briefly press the MODE selector in the middle.

To return to the main "MENU", select "Exit" on the menu and press the MODE selector briefly in the middle.



### 1.4) Calibration (Calibration)

When the Calibration function is selected (with the vehicle at a standstill), a screen appears with the following description in the bottom right of the display:

Calibration running Speed not correct

#### CAUTION

**THE MGCT INDICATOR LIGHT TURNS ON TO INDICATE THAT THE SYSTEM IS DISABLED**



To calibrate the MGCT system (Moto Guzzi Control Traction) ride along a flat straight road in second gear at a speed of 30 +/- 2 km/h (18.64 +/- 1.24 mph) for about 10 seconds, until the digital display shows a message "Calibration running Hold speed".





If the calibration is successful, the following message will be displayed "Calibration done Key OFF".

#### NOTE

**WHEN THE "Calibration done Key OFF" SCREEN DISAPPEARS FROM THE DISPLAY, TO COMPLETE THE CALIBRATION PROCEDURE STOP THE VEHICLE AND SWITCH OFF THE PANEL FOR AT LEAST 60 SECONDS.**

**THIS ALLOWS THE CALIBRATION TO BE STORED IN THE MEMORY.**

#### NOTE

**THE CALIBRATION OPERATION IS USED TO OPTIMISE THE MGCT FUNCTION IN CASE OF A CHANGE IN TYRE TYPE.**

#### NOTE

**TURN THE IGNITION SWITCH OFF TO ABORT THE CALIBRATION PROCEDURE.**

**DURING CALIBRATION, THE MGCT SYSTEM IS AUTOMATICALLY REACTIVATED (IF PREVIOUSLY DEACTIVATED).**

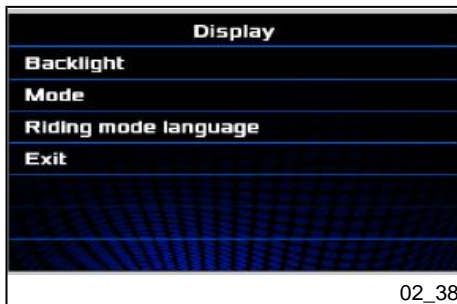

## 2) Display

The "Display" menu consists of the following:

- 2.1) Backlight
- 2.2) Mode
- 2.3) Riding mode language
- 2.4) Exit

The functions of the "Display" menu are shown in the paragraphs below.

To return to the main "MENU", select "Exit" on the menu and press the MODE selector briefly in the middle.

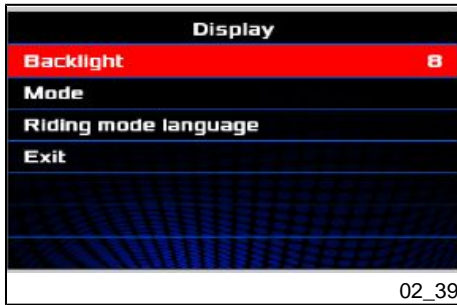

### 2.1) Backlight (Backlight)

This function allows you to change the backlight of the digital display, from a minimum value of 1 to a maximum value of 10.

Lightly pressing the middle of the MODE selector highlights the "Backlight" function in red. Briefly moving the MODE selector upward or downward, the intensity of the backlight increase or decreases.

Pressing the MODE selector again confirms the value selected and exits the modification function.

To return to the "Display" menu, select "EXIT" on the menu and press the MODE selector briefly in the middle.

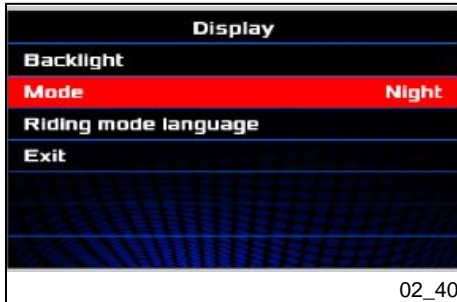

### 2.2) Mode (Mode)

This function allows you to change the display mode of the digital display:

- AUTO.
- DAY (Day).
- NIGHT (Night).

Lightly pressing the middle of the MODE selector highlights the "Mode" function in red. Briefly shifting the MODE selector to the left or right, it is possible to select the preferred mode.

Pressing the MODE selector again confirms the selection and exits the modification function.

To return to the "Display" menu, select "EXIT" on the menu and press the MODE selector briefly in the middle.

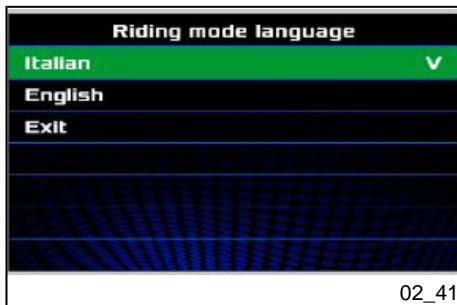

### 2.3) Riding mode language

This function allows to change the display language of the riding mode in the digital display:

- Italian.
- English.
- Exit.

Briefly moving the MODE selector up or down, the preferred language can be selected and confirmed with the side check mark "V".

To return to the "Display" menu, select "EXIT" on the menu and press the MODE selector briefly in the middle.



### 3) Dashboard (Dashboard)

The "Dashboard" menu consists of the following:

- 3.1) Clock (Clock).
- 3.2) MGMP pairing (MGMP pairing).
- 3.3) MGMP pairing reset.
- 3.4) Units (Units).
- 3.5) Languages (Languages).
- 3.6) Exit (Exit).

The functions of the "Dashboard" menu are shown in the paragraphs below.

To return to the main "MENU", select "Exit" on the menu and press the MODE selector briefly in the middle.



### 3.1) Clock (Clock)

The "Clock" menu is composed of the following:

- 3.1.1) Set time (Set time)
- 3.1.2) 12H
- 3.1.3) 24H
- 3.1.4) Exit (Exit)

The functions of the "Clock" menu are shown in the paragraphs below.

To return to the main "MENU", select "Exit" on the menu and press the MODE selector briefly in the middle.



#### 3.1.1) Set time (Set time)

This menu allows you to set the clock and is divided in turn into the following entries:

- 3.1.1.1) Hours (Hours)
- 3.1.1.2) Minutes (Minutes)
- 3.1.1.3) Exit (Exit)

The functions of the "Set time" menu are shown in the paragraphs below.

To return to the "Clock" menu, select "Exit" on the menu and press the MODE selector briefly in the middle.



### 3.1.1.1) Hours (Hours) / 3.1.1.2) Minutes (Minutes)

To edit and as a result modify the value of one of the two selected functions, press the MODE selector briefly in the middle. The background of the selected function turns red.

Briefly moving the MODE selector up or down, it is possible to change the value.

To exit the modification function, press the MODE selector briefly.

To return to the "Clock" menu, select "Exit" on the menu and press the MODE selector briefly in the middle.

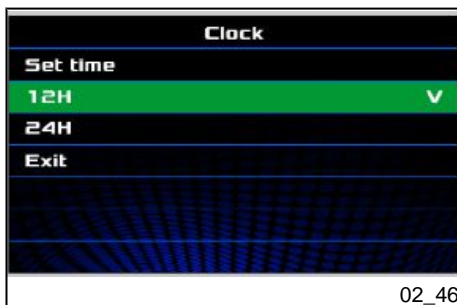

### 3.1.2) 12H / 3.1.3) 24H

To render active the time display format, 12H or 24H, briefly press the middle of the MODE selector at the format desired. The confirmation of the desired selection is indicated by the side check mark "V".

To return to the "Dashboard" menu, select "Exit" on the menu and press the MODE selector briefly in the middle.

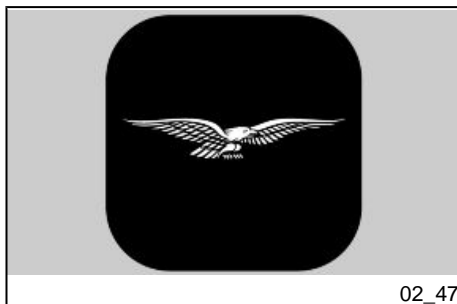

### 3.2) MGMP pairing (where required)

The vehicle is equipped with the "MOTO GUZZI MIA" control unit that communicates with the smartphone via Bluetooth. Using the specific "MOTO GUZZI" application installed on the smartphone, it is possible to exchange data with the vehicle and manage multimedia contents. Once a connection is established correctly between the control unit and the smartphone, the following functions can be directly managed by the digital display of the vehicle:

- manage phone calls;
- manage audio playback;
- GPS navigation.

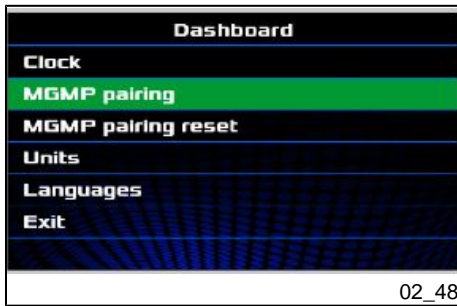

Highlight the "MGMP pairing" function and briefly press the MODE selector in the middle.



The message confirming that pairing with the smartphone is enabled appears on the digital display. Enable the bluetooth search on your smartphone, select the "BT-ROUTER" device, if required, enter the password "0000" and press on pair.



The "BT-ROUTER" device will be visible in the list of associated devices on the smartphone. Wait for the digital display to automatically connect the smartphone. **Do NOT force the connection from the telephone.** The smartphone icon on the display indicates active communication. **When requested, allow phone book and notifications sharing.** These enabling operations are necessary to display the caller's name on the display.

#### NOTE

**UPON THE FIRST PAIRING BETWEEN THE DISPLAY AND SMARTPHONE, MORE TIME MAY BE REQUIRED FOR THE SYNCHRONIZATION OF THE PHONE BOOK.**

THE CONNECTION BETWEEN THE SMARTPHONE AND VEHICLE WILL BE SIGNALLED BY THE LIGHTING OF THE SMARTPHONE ICON ON THE DISPLAY.



#### CONNECTION BETWEEN THE APPLICATION AND THE DIGITAL DISPLAY

Search for the **"MOTO GUZZI"** application in Play Store or App Store and install it. Register your account by following the instructions. Select **"allow"** for the position and notifications management requests.

#### BLUETOOTH HEADSET PAIRING

The multimedia functions can be used with the MODE selector, by pairing a bluetooth headset with the digital display via the **"MOTO GUZZI"** application. After pairing it will be possible to answer or reject calls, activate voice commands and control the music on the smartphone.



Activate the **"pairing"** mode of the bluetooth headset to be paired (refer to the instructions of the device itself). Press the Bluetooth icon on the main screen of the **"MOTO GUZZI"** application and perform a new search for devices until the headset is displayed. Select the bluetooth headset, check the **"Handsfree/driver headset"** option and press **"Pair"**. Successful pairing is indicated by the helmet icon displayed on the digital display. If the pairing is not successful, perform a new search.

Repeat the operation to connect a second device also. If this pairing procedure is successful, the 2nd helmet icon will be highlighted in blue on the digital display.



No multimedia function can be managed from the handlebar of the vehicle if there is no bluetooth headset, or if the headset is directly connected to the smartphone. **The Bluetooth headset can be paired with the vehicle only via the "MOTO GUZZI" application and it must be connected to the vehicle in order to correctly use the multimedia functions of the system. For this reason, the headsets that automatically connects to the smartphone are not compatible (Ex: Apple Airpod).**

**If pairing between Smartphone and Vehicle is not successful, proceed as follows:**

- restart the smartphone;
- turn the ignition key to "**OFF**" and then to "**ON**"; wait for the animation on the display to end.

If the smartphone icon on the display is not illuminated after approximately 1 minute, proceed as follows;

- open "**MOTO GUZZI**" and select "**Connect**";
- select your vehicle from the list of suggestions and follow the instructions on the device;
- once the Application is connected, select the Bluetooth icon that appears on the main screen;
- open the Bluetooth devices menu;
- select "**Configure**" and delete all paired devices, leaving the current device as the last one;
- make sure that the application icon on the display is off;
- turn the ignition key to "**OFF**" and then to "**ON**", then wait until the animation on the screen ends;
- the display must show the pop up "**No connected device**";
- repeat the pairing procedure from the start.



**NOTE**

PLEASE NOTE THAT TO CONNECT THE APP TO THE VEHICLE AGAIN, THE FOLLOWING WILL BE NECESSARY:

- ON iOS, DELETE THE PREVIOUSLY INSTALLED APP AND REINSTALL IT.
- ON ANDROID, SIMPLY DELETE THE APPLICATION DATA FROM THE APP MANAGEMENT MENU (THIS WILL RETURN THE APPLICATION TO THE INITIAL CONDITION AND THE LOGIN AND FIRST CONNECTION TO THE VEHICLE MUST BE PERFORMED AGAIN).
- IN CASE OF CONNECTION TO A NEW VEHICLE, IT IS NECESSARY TO REMOVE THE PREVIOUS BT-ROUTER FROM THE ASSOCIATED DEVICES.

**NOTE**

IT IS RECOMMENDED TO PAIR A MAXIMUM OF 2 SMARTPHONES AND 2 HEADSETS TO THE SAME VEHICLE, TO OPTIMIZE THE OPERATION OF THE SYSTEM.

IN THE CASE OF PAIRING THE SECOND SMARTPHONE, NOTE THAT THE SECOND ONE WILL REQUIRE A LONGER TIME (MORE THAN 30 SECONDS) CONNECT TO THE "BT-ROUTER". ONCE THE SMARTPHONE IS CONNECTED TO THE "BT-ROUTER", THE OPERATING SYSTEM WILL REQUEST ACCESS TO THE PHONE BOOK AND TO THE NOTIFICATIONS; ACCEPT TO DISPLAY THE NAMES OF THE CALLERS ON THE DISPLAY.

**Required operation for iOS 10.0 versions or higher**

If the "BT-ROUTER" device does not automatically request permission to share notifications, the following procedure is necessary:

- Enter the menu: "Settings" > "Bluetooth" > "Phone devices";
- select "BT-ROUTER", select "Info", enable the options manually.

**INTERCOM AND VOCAL COMMANDS MANAGEMENT**

The "MOTO GUZZI" system manages the connection between the intercom and smartphone upon activation by the user.



**FOR SAFETY REASONS, IT IS RECOMMENDED TO CARRY OUT THE ACTIVATION / DEACTIVATION PROCEDURES WITH THE VEHICLE AT A STANDSTILL.**



To activate the "INTERCOM" function, from the main screen it is necessary to move the MODE selector down.

An "INTERPHONE ACTIVATED" pop-up will be shown for a limited time on the digital display.



Subsequently, the sound level can be adjusted using the MODE selector, before the pop-up disappears.

At this point, the "interphone" icon will switch on.



A further downward movement of the MODE selector deactivates the connection, showing the message "INTERPHONE DEACTIVATED" on the digital display.



To activate the "VOICE" function which allows using the smartphone, by giving voice commands via the handsets (e.g. Siri or Google Assistant), long press the activation button of the heated hand grips.



**THE "VOICE" FUNCTION CANNOT BE ACTIVATED IF THE "INTERCOM" FUNCTION IS ALREADY ACTIVATED.**

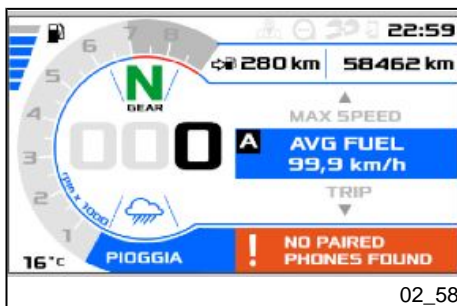

### 3.3) MGMP pairing reset

This function is used to reset the pairing function, and therefore allows removing all previously memorized devices.

#### NOTE

**PERFORM A KEY OFF/ON TO VALIDATE THE OPERATION. UPON KEY ON, THE MESSAGE "NO PAIRED PHONES FOUND" WILL BE SHOWN (TELEPHONE NOT PAIRED).**



### 3.4) Units (Units)

This menu allows you to change the settings for displaying the units and is divided as follows:

- 3.4.1) Speed (Speed)
- 3.4.2) Fuel consumption (Fuel consumption)
- 3.4.3) Temperature (Temperature)
- 3.4.4) Exit (Exit)

To return to the "Dashboard" menu, select "EXIT" on the menu and press the MODE selector briefly in the middle.



#### 3.4.1) Speed (Speed)

To render active the desired units, expressed in km/h or in MPH, select the unit and briefly press the MODE selector in the middle. The confirmation of the selection is indicated by the side check mark "V"

To return to the "Units" menu, select "Exit" on the menu and press the MODE selector briefly in the middle.

#### NOTE

**IF THE UNIT OF MEASURE SET AT THE FACTORY HAS BEEN CHANGED, THE SPEED'S UNIT OF MEASURE WILL FLASH FOR 30 SECONDS EACH TIME THE KEY IS ENGAGED.**

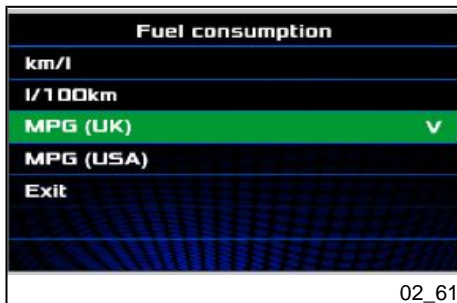

### 3.4.2) Fuel consumption (Fuel consumption)

To render active the desired units, regarding fuel consumption, after having selected it, briefly press the MODE selector in the middle. The confirmation of the selection is indicated by the side check mark "V"

To return to the "Units" menu, select "Exit" on the menu and press the MODE selector briefly in the middle.

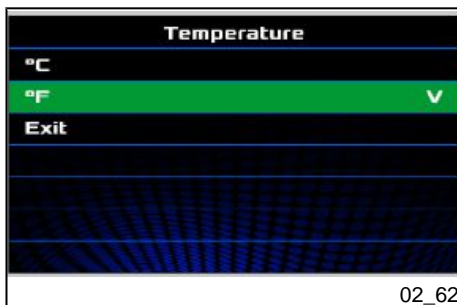

### 3.4.3) Temperature (Temperature)

To render active the desired units, regarding ambient temperature, briefly press the MODE selector in the middle at the desired value. The confirmation of the selection is indicated by the side check mark "V".

To return to the "Units" menu, select "Exit" on the menu and press the MODE selector briefly in the middle.



### 3.5) Languages (Languages)

This menu allows you to set the display language of the dashboard.

To render active the desired language, briefly press the MODE selector in the middle at the desired language. The confirmation of the selection is indicated by the check mark "V".

To return to the "Units" menu, select "Exit" on the menu and press the MODE selector briefly in the middle.



#### 4) Service (Service)

The "Service" menu consists of the following:

- 4.1) Change user code (Change user code)
- 4.2) Code recovery (Code recovery)
- 4.3) EXIT (Exit)

The functions of the "Service" menu are shown in the paragraphs below.

To return to the main "MENU", select "Exit" on the menu and press the MODE selector briefly in the middle.



#### 4.1) Change user code (Change user code)

This function may be used to modify the existing code (you must be in possession of the code itself in order to do this). The user code enables engine start even in the event of an immobiliser system fault. The user code is set by default as five zeros (00000) on a new vehicle, and the message "INSERT CODE" is shown on the display for ten seconds.

This function allows you to change the code itself and remove this message.

On the value to the leftmost of the display a value from 0 to 9 will be shown (which can be modified by moving the MODE selector upward or downward). Press the centre of the "MODE" selector briefly to confirm the selection. Repeat the operation for all the digits. Once the code is confirmed, the new code is shown steadily on the display to let the user verify that the code has been entered correctly. Turn the ignition off and then on again to unlock the dashboard. The last code set may be modified again in future. Access the setting mode again, enter the last user code used (OLD CODE), then enter a new user code (NEW CODE) as described previously.



#### 4.2) Code recovery (Code recovery)

This function must be used should it be necessary to change the user code when the user no longer remembers the current code. Both keys stored in the vehicle memory are needed to access this function.

When the function is activated, by pressing briefly on the middle of the MODE selector, the screen "INSERT KEY 1" is displayed to signal the recognition request of the first key. Insert the key. If the correct key is recognised within twenty seconds, the message "INSERT KEY 2" is shown on the display. Insert the second key. If the second key is also recognised within twenty seconds, the dashboard resets the user code to the default code (five zeros - 00000). Enter the new user code following the "CHANGE USER CODE " procedure.



#### CUSTOM MODE

After having been selected, the custom mode function, can be immediately accessed by long pressing the MODE selector directly from the main screen.

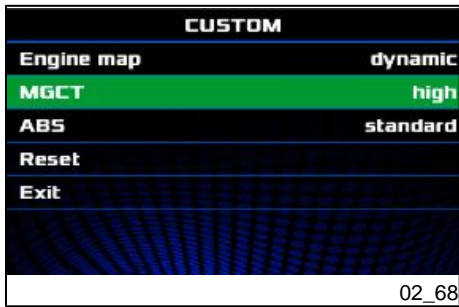

This function is used to set the parameters of the RIDING MODE, which can be selected with the function "MAPPING SELECTION".

The parameters to be selected are:

- 1) Engine map (Engine map)
- 2) MGCT (Moto Guzzi Controllo Trazione)
- 3) ABS
- 4) Reset
- 5) Exit (Exit)

To scroll through the various entries, press the MODE selector up/down. To exit the "Custom Mode" function, select EXIT and briefly press the MODE selector in the middle position.



### 1) Engine map

This function allows to adjust the power supply level, regulated by the engine control unit. The available options are: DYNAMIC, STANDARD and SOFT.

To adjust the parameter, once "Engine map" has been selected, briefly press the MODE selector in the middle. The parameter will then be displayed in red with the set value shown on the side. Change the parameter by pressing the MODE selector up/down.

Press the MODE selector briefly in the middle to return to the parameters selection screen.





## 2) MGCT (Moto Guzzi Controllo Trazione)

This function allows to adjust the traction control level. The available options are: DE-ACTIVATED, LOW, INTERMEDIATE and HIGH.

To adjust the parameter, once "MGCT" has been selected, briefly press the MODE selector in the middle. The parameter will then be displayed in red with the set value shown on the side. Change the parameter by pressing the MODE selector up/down.

Press the MODE selector briefly in the middle to return to the parameters selection screen.

### NOTE

**In case of selecting LOW, the message "Only for off-road" appears in the display.**

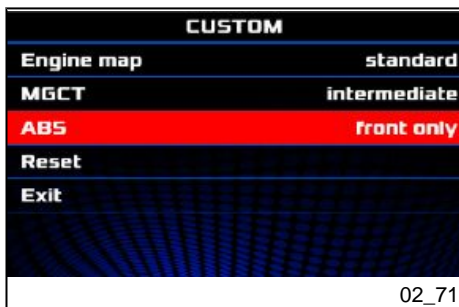

## 3) ABS

This function allows to adjust the operation level of the ABS system. The available options are: ONLY FRONT and STANDARD.

To adjust the parameter, once "ABS" has been selected, briefly press the MODE selector in the middle. The parameter will then be displayed in red with the set value shown on the side. Change the parameter by pressing the MODE selector up/down.

Press the MODE selector briefly in the middle to return to the parameters selection screen.

### NOTE

**It is not possible to deactivate this parameter with this function. If you want to deactivate this entry, refer to the "menu" section within the "ADVANCED FUNCTIONS".**

**If the option ONLY FRONT is selected, the message "rear ABS deactivated" appears in the display.**

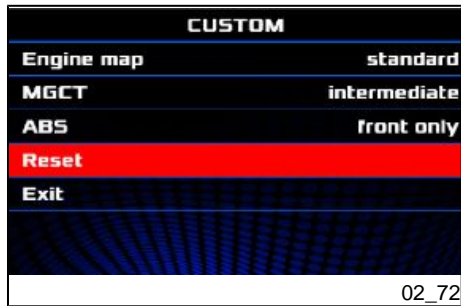

#### 4) RESET

This function allows to restore all parameters of the mapping "CUSTOM MODE" to the original values.

To reset the parameters, once the "RESET" entry has been selected, briefly press the MODE selector in the middle, then select "YES" and confirm with briefly pressing the MODE selector.

To return to the "ADVANCED FUNCTIONS" screen, select "Exit" on the menu and press the MODE selector briefly in the middle.

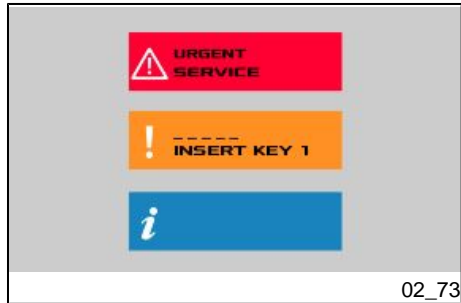

#### SYSTEM MESSAGES "MOTO GUZZI MIA"

The «MOTO GUZZI MIA» system communicates with the user through messages that can be viewed on the graphic panel of the digital display. Depending on the message type, the graphic panel shows the icon, colours and the specific message. The image opposite displays:

- Text alarms, contact an **Authorised Service Centre**;
- Warning messages;
- Info messages.

#### NOTE

**THE MODE SELECTOR COMMANDS ARE IGNORED WHEN A POPUP IS PRESENT ON THE DISPLAY. TO RESTORE THE STANDARD USE, IT IS NECESSARY TO REMOVE THE POPUP FROM THE DISPLAY FIRST.**



02\_74

## CALL MANAGEMENT

To use phone features, view caller notifications and identifiers, it is necessary to:

- pair the smartphone with the "MOTO GUZZI MIA" system via Bluetooth, as previously described;
- install and log in to the "MOTO GUZZI" application with your account on the smartphone;
- pair a bluetooth headset to the "MOTO GUZZI MIA" system via the «MOTO GUZZI» application;
- allow sharing of the phone book and notifications when the smartphone is paired with the "MOTO GUZZI MIA" system.
- The corresponding three icons are shown on the digital display. Please note that on iOS systems the message notifications will be displayed **ONLY** at the second connection of the smartphone to the vehicle.

## NOTE

**WHEN A SMARTPHONE CONNECTS WITH THE «MOTO GUZZI MIA» SYSTEM (BT-ROUTER), AUDIO IS AUTOMATICALLY ROUTED TO THE MOTO GUZZI MIA SYSTEM. IF THERE IS NO HEADSET CONNECTED TO THE "MOTO GUZZI MIA" SYSTEM, THE AUDIO FUNCTION OR MUSIC PLAYBACK CANNOT BE MANAGED, THEREFORE THE SMARTPHONE AUDIO MUST BE MANUALLY ROUTED TO THE DESIRED DEVICE (E.G. SPEAKERS/TELEPHONE MICROPHONE).**

The following information appears on the digital display:

- call in progress;
- call ended;
- voice control active.

## **MODE SELECTOR FUNCTIONS FOR CALL MANAGEMENT**

Accept incoming call	CENTRAL BUTTON BRIEF PRESS
End an active call	CENTRAL BUTTON LONG PRESS
Reject incoming call	CENTRAL BUTTON LONG PRESS
Cancel outgoing call	CENTRAL BUTTON LONG PRESS
Clear most recent missed call popup (with NO call in progress)	CENTRAL BUTTON BRIEF PRESS
Redial last missed call number (with NO call in progress)	CENTRAL BUTTON LONG PRESS
Increase volume (with call in progress)	BRIEF PRESS UPWARD
Lower volume (with call in progress)	BRIEF PRESS DOWNWARD

### **MANAGING A SECOND CALL**

If the smartphone paired with the "MOTO GUZZI MIA" system is capable of receiving a second incoming call, a number of functions for managing a second call are available.

A popup appears on the digital display showing the identification details of the current and of the new incoming call are displayed in alternation (at intervals of approximately 1 second).

If the second incoming call is not accepted, a pop-up appears at the end of the ongoing conversation with details of the missed call.

## **FUNCTIONS OF MODE SELECTOR FOR MANAGING SECOND CALL**

Accept incoming call and put current call on hold	CENTRAL BUTTON BRIEF PRESS
Reject incoming call and continue current call	CENTRAL BUTTON LONG PRESS



### **MUSIC PLAYBACK MANAGEMENT**

To use the functions of the music player, the following must be performed:

- pair the smartphone with the "MOTO GUZZI MIA" system via Bluetooth, as previously described;
- install and log in to the "MOTO GUZZI" application with your account on the smartphone;
- pair a bluetooth headset to the "MOTO GUZZI MIA" system via the «MOTO GUZZI» application.

The corresponding three icons are shown on the digital display.

### **NOTE**

**WHEN A SMARTPHONE CONNECTS WITH THE «MOTO GUZZI MIA» SYSTEM (BT-ROUTER), AUDIO IS AUTOMATICALLY ROUTED TO THE MOTO GUZZI MIA SYSTEM.**

**IF THERE IS NO HEADSET CONNECTED TO THE "MOTO GUZZI MIA" SYSTEM, THE AUDIO FUNCTION OR MUSIC PLAYBACK CANNOT BE MANAGED, THEREFORE THE SMARTPHONE AUDIO MUST BE MANUALLY ROUTED TO THE DESIRED DEVICE (E.G. SPEAKERS/TELEPHONE MICROPHONE).**

The following information appears on the digital display:

- track playing;
- playback paused;
- playback interrupted.

Use the MODE selector to manage audio playback as shown in the table:

### **MODE SELECTOR FUNCTIONS FOR MUSIC MANAGEMENT**

Play track	CENTRAL BUTTON BRIEF PRESS
Increase audio volume (with audio playback in progress)	BRIEF PRESS UPWARD
Lower audio volume (with audio playback in progress)	BRIEF PRESS DOWNWARD
Next music track	LONG PRESS UP
Previous audio track	LONG PRESS DOWN
Play / pause	CENTRAL BUTTON BRIEF PRESS
Exit audio playback mode	CENTRAL BUTTON LONG PRESS
Intercom activation (when music is NOT active)	LONG PRESS DOWN



02\_76

## GPS NAVIGATION

Combined with the "MOTO GUZZI" application, the "MOTO GUZZI MIA" system allows the display of GPS indications on the digital display. By means of pictograms, distance and travel time data, the desired destination can be reached.

Refer to the navigation guide by accessing the "MOTO GUZZI" application with your account. The navigation icon appears on the digital display after setting the destination address.

The GPS directions screen is accessed by pressing the MODE selector UPWARDS.

### NOTE

**BY SETTING THE DESTINATION ADDRESS VIA THE "MOTO GUZZI" APPLICATION, THE DIGITAL DISPLAY AUTOMATICALLY DISPLAYS THE INDICATION SCREEN.**

### NOTE

**"SHORT PRESS": PRESS THE BUTTON AND RELEASE WITHIN 0.5 SECONDS;**

**"PRESS AND HOLD": PRESS THE BUTTON AND HOLD FOR AT LEAST 2 SECONDS.**

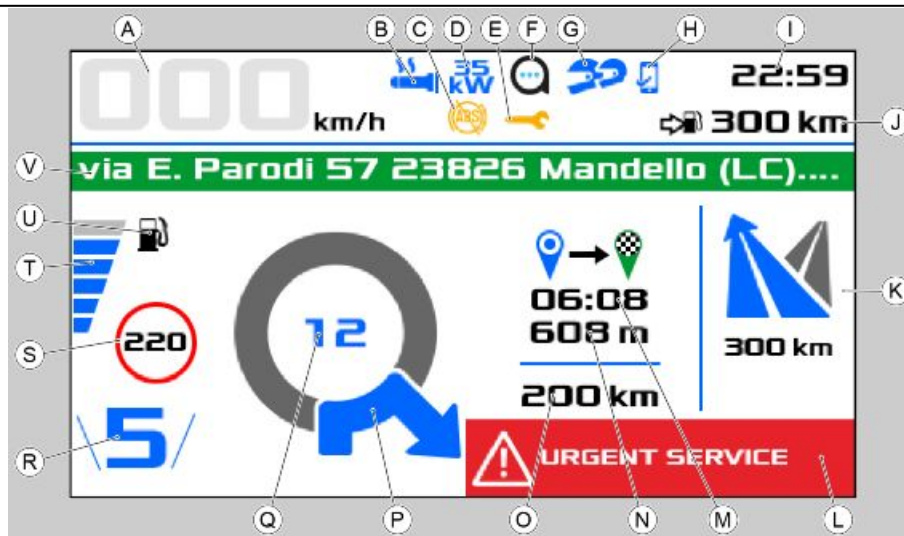

02\_77

#### Navigation screen key:

- A = speed (speedometer) (viewable in km/h or in mph);
- B = heated hand grips (where required);
- C = ABS system indicator only on front wheel in the "OFF ROAD" mode only;
- D = Presence of underpowered map indicator (35kW);
- E = service icon;
- F = data link with smartphone;
- G = rider/passenger intercom;



**H** = audio link with smartphone used to make calls, use voice commands and play music;

**I** = clock (time viewable in 24 or 12 hour format, without AM / PM indication);

**J** = remaining km/mi of current journey;

**K** = symbol of manoeuvre after next manoeuvre, and relative distance;

**L** = information pop-up;

**M** = time remaining to arrival at destination;

**N** = distance remaining to arrival at destination;

**O** = distance relative to indication "P";

**P** = next manoeuvre symbol;

**Q** = number of exit to take from roundabout;

**R** = gear selected (displayed only with engine running and vehicle moving);

**S** = speed limit applicable on current road;

**T** = fuel gauge;

**U** = fuel reserve icon;

**V** = destination address;

## **Ignition switch (02\_78)**

The ignition switch is on the front of the fuel tank where the steering headstock is.

The vehicle is supplied with two keys (one is the spare key).

The lights can only be switched off with the ignition switch turned to OFF.

**NOTE**

THE KEY IS USED IN THE IGNITION/STEERING LOCK SWITCH, THE KEYHOLE FOR THE FUEL TANK CAP, AND FOR THE SADDLE COMPARTMENT.

**NOTE**

THE LIGHTS COME ON AUTOMATICALLY AFTER THE ENGINE STARTS.

**NOTE**

KEEP THE SPARE KEY IN DIFFERENT PLACE, NOT WITH THE VEHICLE.

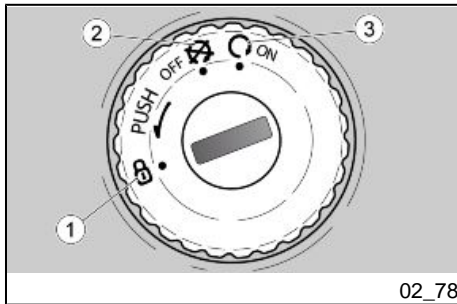

**LOCK (1):** The steering is locked. It is not possible to start the engine or switch on the lights. The key can be extracted

**OFF (2):** The engine and lights cannot be set to work. The key can be extracted.

**ON (3):** The engine can be started. The key cannot be extracted.

**Locking the steering wheel (02\_79)**

**TO PREVENT THE LOSS OF CONTROL, NEVER TURN THE KEY TO THE "LOCK" POSITION WHILE THE VEHICLE IS RUNNING.**

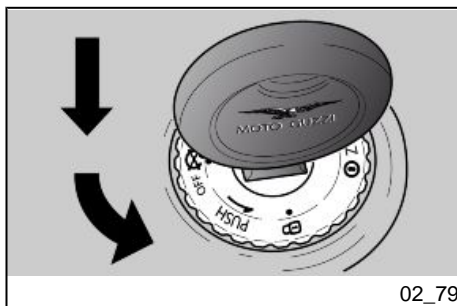

### To lock the steering:

- Turn the handlebar fully to the left.
- Turn the key to «OFF».
- Push in the key and turn it anticlockwise (to the left), steer the handlebar slowly until the key is set to «LOCK».
- Extract the key.

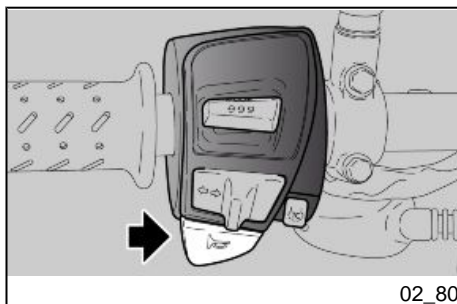

### Horn button (02\_80)

Press it to activate the horn.

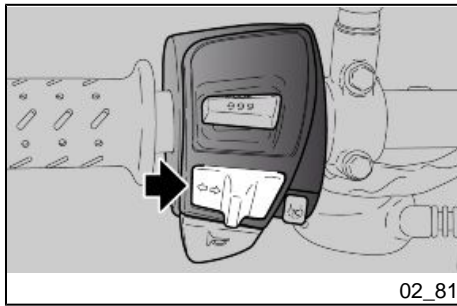

## Switch direction indicators (02\_81)

Move the switch to the left to indicate a left turn; move the switch to the right to indicate a right turn. Pressing the switch deactivates the turn indicator.

### CAUTION

**IF THE INDICATOR LIGHT WITH ARROWS FLASHES QUICKLY, IT MEANS THAT ONE OR BOTH TURN SIGNALS LIGHT BULBS ARE BURNT OUT.**

The turn indicators have a self-cancelling function that implements the following logic.

With the vehicle at standstill (speed = zero), the turn indicators continue flashing indefinitely.

With the vehicle in motion, the turn signals self-cancel when one of the two following conditions is met:

- After a time (t) = 40 sec.
- After riding 500 m (0.31 mi)

If the vehicle speed reaches zero during this period, the time and distance counts are reset and start again from zero when the vehicle starts moving once again.

Switching on the opposite side turn indicators without pressing the switch in the intermediate reset position causes both the time and distance counters to reset and recommence from zero.

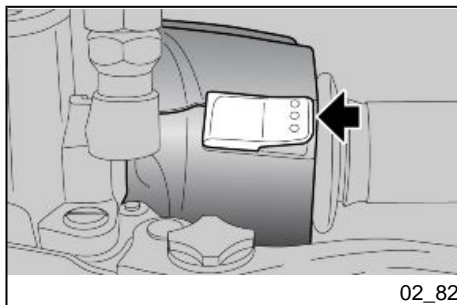

## High/low beam selector (02\_82)

In the mode with daytime lights activated:

- the light switch functions are disabled except for the high beam flasher function
- In the right hand position the high beam flashes in case of danger or emergency.

In the mode with night lights activated:

- the switch in the central position keeps the daylight running lights, the instrument panel lights and the low beam on.
- In the left hand position the high beam is activated.
- In the right hand position the high beam flashes in case of danger or emergency.

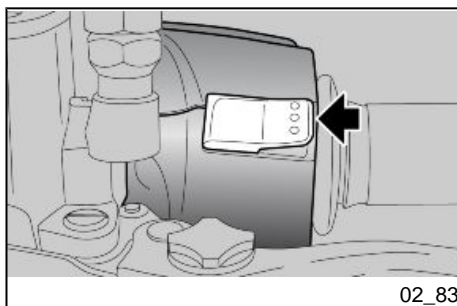

## Passing button (02\_83)

Press the button to flash the high beam headlamp to signal danger or an emergency.

Releasing the switch deactivates the high beam flash.

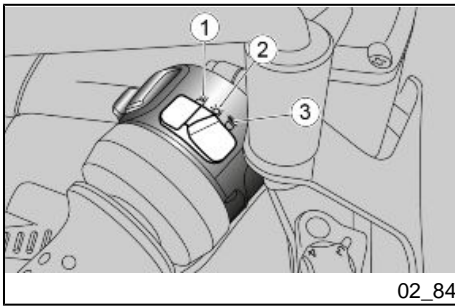

### Daytime/night lights switch (02\_84)

- Directing the switch downward, the rider (1) activates the night lights
- Directing the switch to the central position (2) turns on the high beam/low beam night lights
- Directing the switch forwards (3) activates the high beam/low beam lights and, where provided, the fog lights.

### Heated handgrip control (02\_85, 02\_86)

(WHERE AVAILABLE)

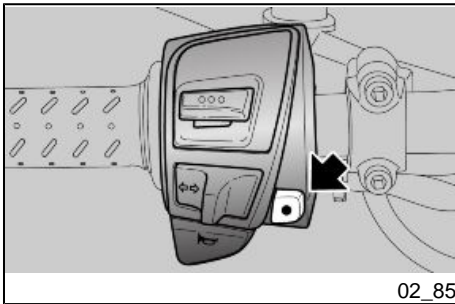

The activation, deactivation and heat level of the grips takes place through a short press of the control.



The heat intensity has 3 levels and is cyclically activated from level 1 (minimum intensity) to level 3 (maximum intensity), on each short press of the control. Subsequently at level 3 with another short press on the command the function is deactivated.

If the key is switched to the OFF position, upon restarting the function will be deactivated.

#### NOTE

**THE HEATING OF THE GRIPS, AS WELL AS THE LEVEL OF CHOSEN INTENSITY, IS POSSIBLE ONLY WITH THE ENGINE RUNNING AND ABOVE 2000 rpm**

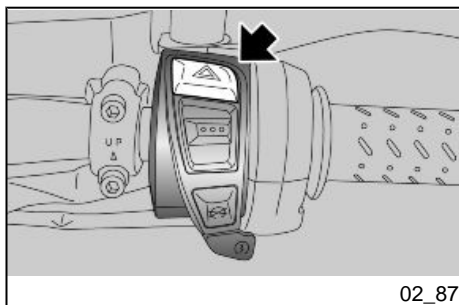

#### Flasher button (02\_87)

The HAZARD system is only available at key ON. By pressing the button, the four turn indicators and their warning lights on the panel are turned on at the same time. Pressing again deactivates the system. The HAZARD light remains on even after extracting key but it cannot be deactivated.

If the key is switched to the OFF position, upon restarting the function will be deactivated.

#### CAUTION

**IF A TURN INDICATOR IS SWITCHED ON WHILE THE HAZARD SYSTEM IS ACTIVE, THE HAZARD SYSTEM IS DISABLED TEMPORARILY UNTIL THE TURN INDICATOR IS RESET.**

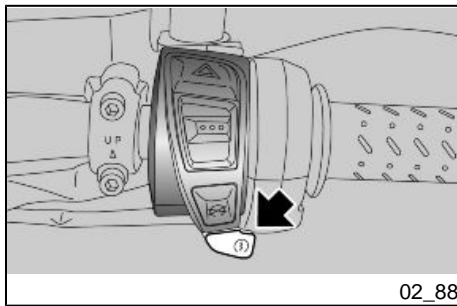

### Start-up button (02\_88)

With the key in the ignition and turned to ON, when the button is pressed, the starter motor will start the engine



**AFTER A FEW SECONDS FROM THE ENGINE START-UP, THE START-UP BUTTON ASSUMES THE MAPPING CHANGE FUNCTION.**

### Engine stop switch (02\_89)

**CAUTION**



**DO NOT OPERATE THE ENGINE STOP SWITCH WHILE RIDING THE VEHICLE.**

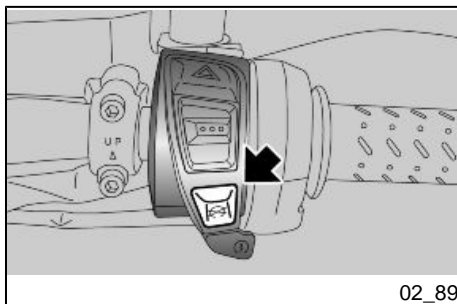

It acts as a safety or emergency switch.

Press this switch to stop the engine.



## Button Cruise Control (02\_90, 02\_91)

### CAUTION

**IN NAVIGATOR MODE THE DISPLAY OF THE SPEED SET VIA THE CRUISE CONTROL WILL NO LONGER BE VISIBLE.**

**THE CRUISE CONTROL WILL CONTINUE TO OPERATE REGULARLY.**

**THE ACTIVATION MODE OF THE DEDICATED INDICATOR WILL BE UN-CHANGED.**



Cruise control is an electronic system that keeps the vehicle at a constant speed selected by the rider.

To turn the system (switching from OFF to ON state) it is required to centrally press the cruise control selector with a long press (longer than 1 second), the system power is indicated by the warning light on the instrument cluster in flashing mode.

The system can be used in certain ranges of speeds for the gears from the second to the sixth, even during deceleration and with the throttle grip released.

#### Minimum:

- 30 km/h (18.64 mph) for second gear
- 35 km/h (21.75 mph) for third gear
- 40 km/h (24.85 mph) for fourth gear
- 55 km/h (34.18 mph) for the fifth and sixth gears

#### Maximum:

- 60 km/h (37.28 mph) for second gear
- 85 km/h (52.82 mph) for third gear
- 110 km/h (68.35 mph) for fourth gear
- 135 km/h (83.89 mph) for fifth gear
- 175 km/h (108.74 mph) for sixth gear

After reaching the desired speed, the system can be activated (transition to SET state) by a short central press (less than 1 second) of the cruise control selector under the following conditions:

- The engaged gear cannot be less than the third and even in neutral;
- The brakes should not be operated;

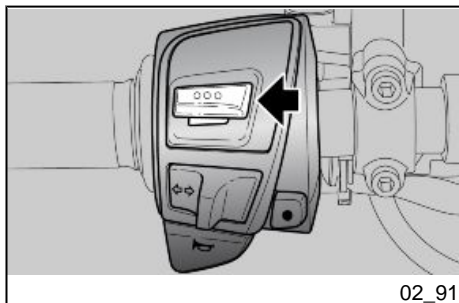

- The clutch must not be operated;
- The speed conforms to the limit established for each gear

The indicator lamp on the instrument cluster lights continuously to indicate that the system is active.

The rider may now release the throttle grip, as the system will automatically maintain the set speed.

It is possible to increase or decrease the cruising speed by a short press (less than 0.6 seconds) of the cruise control switch up or down (increase / decrease the speed of 2 km/h (1.24 mph)) or via a long press (from 1 to 20 seconds) up or down (increase / decrease in the constant speed). The throttle may be used to increase speed temporarily by up to 30 km / h (18.64 mph) for the second, third, and fourth gear and 40 km/h (24.85 mph) for the fifth and sixth gear with respect to the selected speed without turning off the system (e.g. passing). If the increase in speed exceeds 30 km/h (18.64 mph) for the third, fourth and fifth gear and 40 km/h (24.85 mph) for the sixth gear, it will cause a system deactivation (change from SET to ON, flashing light). Released the throttle grip, the motorcycle will return to the selected cruising speed. For each gear, exceeding the maximum limit of 20 Km/h (12.43 mph) causes the system to deactivate (switching from SET to ON status, or at flashing warning light).

The system is deactivated (change from SET to ON status) if any of the following conditions:

- By operating the clutch;
- Operating the front/rear brake;
- On every possible gear shift;
- Pressing with a short central pressure the left selector;
- If the engine rpm limiter is activated;
- If the tracking control is activated;
- If climbs or particularly steep descents appear;
- Turning the throttle grip in the direction of contrary rotation

It is possible to reactivate the system, always respecting the conditions described above, via a long press (more than 0.6 seconds) of the selector if you want to reconfirm the last cruising speed used (RESUME function), or, by pressing the cruise control

switch with a central prolonged press (greater than 0.6 seconds) to set a new cruising speed.

The system turns off completely (change from SET to the OFF state), then the stored speed is lost and the instrument cluster light goes off, if any of the following conditions are present:

- The cruise control selector is pressed centrally for long (more than 0.6 seconds);
- Run-off interrupter activated;
- Engine stop (Key-OFF);
- In case of malfunction of any device related to the cruise control.

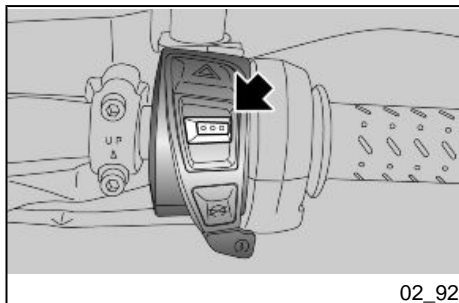

02\_92

### Selector MODE (02\_92)

It allows you navigate through the functions of the instrument panel.

### System ABS (02\_93, 02\_94)

The ABS system is a device that prevents wheel locking in case of an emergency braking, thus increasing vehicle stability when braking, compared with a conventional braking system.

The ABS system improves vehicle control provided that the physical limits of vehicle grip on the road are not exceeded. The rider is fully responsible for riding at a suitable



speed based on weather and road conditions, always leaving an appropriate safety margin.

Under no circumstances can the ABS system compensate for the rider's misjudgment or improper use of brakes.

#### NOTE

**WHEN THE ABS STARTS WORKING, A PULSING IS FELT ON THE BRAKE LEVER.**



**THE ANTI-LOCK BRAKING SYSTEM OF THE WHEEL DOES NOT PREVENT FALLS WHILE CORNERING.**

**AN EMERGENCY BRAKING WITH THE VEHICLE INCLINED, HANDLEBAR TURNED, ON UNEVEN OR SLIPPERY ROADS, OR WITH POOR GRIP, CREATES A LACK OF STABILITY DIFFICULT TO HANDLE. RIDE CAREFULLY AND SENSIBLY AND ALWAYS BRAKE GRADUALLY.**

**DO NOT SPEED RECKLESSLY. THE VEHICLE GRIP ON THE ROAD IS SUBJECT TO LAWS OF PHYSICS WHICH NOT EVEN THE ABS SYSTEM CAN ELIMINATE.**

In **OFF ROAD** mode, the ABS system is automatically deactivated for the rear wheel.

#### CAUTION

**ONLY IN THIS MODE DOES THE ABS SYSTEM STAY ACTIVE EXCLUSIVELY FOR THE FRONT WHEEL AND THE DEDICATED SYMBOL APPEARS ON THE DISPLAY TO REMIND THE RIDER TO TAKE PARTICULAR CARE.**

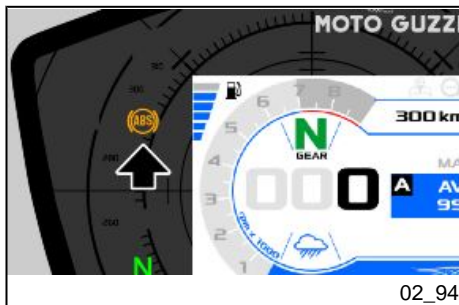

Upon starting the vehicle, after the initial instrument panel check, the ABS indicator light flashes until a speed of 5 kph (3.11 mph) is exceeded and then it switches off or continues to flash even after exceeding the speed of 5 kph (3.11 mph).

If the ABS indicator light continues flashing or is permanently on, a failure has been detected and the ABS has been automatically deactivated.

In this case carry out the following operations:

- stop the vehicle;
- OFF-ON key;
- ride over 5 km/h (3.11 mph): the ABS indicator light must be turned off;
- ABS is functioning.

If the ABS disabled indication remains:

#### NOTE

**IF THIS OCCURS, CONTACT AN Authorised Moto Guzzi dealer**

#### NOTE

**THE ABS HAS BEEN DESIGNED AND DEVELOPED, LIKE THE REST OF THE VEHICLE, ALSO FOR OFF ROAD USE.**

**IF THE VEHICLE IS USED ON PARTICULARLY ROUGH ROADS, THE ABS SYSTEM MAY BE AUTOMATICALLY DISABLED; IN ANY CASE, THE BRAKING SYSTEM WORKS PERFECTLY WELL AS A TRADITIONAL NON-ABS BRAKING SYSTEM WITH NORMAL BRAKING.**

**IN ORDER TO REACTIVATE THE SYSTEM JUST SHUT OFF AND START THE VEHICLE UP AGAIN AND RIDE OVER 5 km/h (3.11 mph).**



**THE ABS SYSTEM ACTS ON BOTH THE FRONT AND REAR WHEELS BY OBTAINING INFORMATION FROM THE ROTATION/ LOCKING TONE WHEELS. ALWAYS CHECK THAT THE TONE WHEEL IS CLEAN, AND REGULARLY CHECK THAT THE DISTANCE FROM THE SENSOR IS CONSTANT ON ALL 360 DEGREES. SHOULD THE WHEELS BE REMOVED AND REFITTED, IT IS VERY IMPORTANT TO CHECK THAT THE DISTANCE BETWEEN TONE WHEEL AND**

**SENSOR IS THE ONE SPECIFIED. FOR CHECKING AND ADJUSTMENT, CONTACT AN Authorised Moto Guzzi Garage.**



**IN THE CASE OF A MOTORCYCLE WITH THE ABS SYSTEM, BRAKE PADS WITH FRICTION MATERIALS THAT ARE NOT TYPE APPROVED WILL JEOPARDISE BRAKING, DRASTICALLY REDUCING RIDING SAFETY.**

#### **NOTE**

**THE SYSTEM'S SENSORS, HAVING A SIGNIFICANT ACCURACY OF READING THE TONE WHEELS, MAY GENERATE, A MOTORCYCLE STOPPED AND THE ENGINE RUNNING, INDICATION OF SPEED OF SOME km / h (mph) ON THE DIGITAL DISPLAY.**

**SUCH BEHAVIOUR IS TO BE CONSIDERED NORMAL AND DOES NOT CREATE MALFUNCTIONS IN THE SYSTEM.**



**IF THE GAP FOR ONE OR BOTH SENSORS IS NOT WITHIN THE TOLERANCE INDICATED BELOW, TAKE THE MOTORCYCLE TO AN Authorised Moto Guzzi Dealer**

#### **Characteristic**

**Distance between tone wheel and front sensor**

0.1 - 2.00 mm (0.004 - 0.079 in)

**Distance between tone wheel and rear sensor**

0.1 - 2,00 mm (0.004 - 0.079 in)

## MGCT system(Moto Guzzi Controllo Trazione) (02\_95)

The MGCT system is a device that helps the rider during acceleration in manoeuvres with the aim to increase the stability of the vehicle, especially on slippery surfaces or in conditions that can cause sudden slippage of the rear wheel. In these situations, the MGCT automatically intervenes by reducing engine output within the limit imposed by the grip conditions, contributing significantly to the maintenance of stability of the vehicle. The rider is entirely responsible for riding at an appropriate speed in relation to the weather, road conditions, vehicle load and state of the tyres, and allowing for an adequate margin of safety, taking into consideration that the physical limits of vehicle grip on the road never have to be exceeded. Under no circumstances can MGCT compensate for any rider error or improper use of the throttle.

### CAUTION



**THE MGCT SYSTEM DOES NOT PREVENT FALLING IN TURNS.**

**ACCELERATING SUDDENLY WHILE THE VEHICLE IS INCLINED OR WITH THE HANDLEBARS TURNED WILL PUT THE VEHICLE IN AN UNSTABLE STATE THAT IS EXTREMELY DIFFICULT TO RECTIFY.**

**DO NOT SPEED RECKLESSLY. LIMITS OF GRIP ARE DETERMINED BY LAWS OF PHYSICS, WHICH EVEN THE MGCT SYSTEM CANNOT OVERCOME.**

### WARNING

**THE MGCT SYSTEM IS BASED ON THE RECOGNITION OF SPEED DIFFERENCES BETWEEN FRONT AND REAR WHEEL. FOR THE SYSTEM TO PERFORM CORRECTLY IN ALL CONDITIONS, THE PROCEDURE MUST BE PERFORMED EACH TIME A TYRE IS REPLACED EVEN IF ONLY ONE OF THE TYRES IS REPLACED.**

**TO CALIBRATE, CARRY OUT THE PROCEDURE OUTLINED IN THE "ADVANCED FUNCTIONS" CHAPTER**



To deactivate the MGCT system, see the "Advanced functions" chapter.

The MGCT system indicator lights consist of orange warning lights on the upper part of the instrument panel and an orange MGCT indicator light on the RH part.

#### Flashing mode:

- Off with the vehicle in gear: the system is working, but is not active (normal condition).
  - Flashing quickly with moving vehicle: the system is up and running (conditions of low grip and intervention to reduce engine power); we recommend the utmost caution because the grip limit has been exceeded; restore the vehicle safety conditions by gently reducing the throttle opening.
  - Permanently on with the vehicle in gear: the system is disabled and will not intervene in case of loss of grip.
    - If deactivation is intentional, we recommend reactivating the system as soon as possible.
    - If deactivation was NOT intentional, there is an MGCT failure: in this case you must contact an Authorised Service Centre for the diagnosis and reactivation of the system.
- To ensure maximum safety of the vehicle it is advisable to keep the system active. Deactivation may only be necessary if starting on very low grip surfaces (mud, snow, gravel) on which intervention of the MGCT could prevent the vehicle from moving.

#### CAUTION

**THE STATE OF THE MGCT SYSTEM CAN ONLY BE MODIFIED WHEN THE KEY IS SWITCHED TO ON.**

#### NOTE

**AT VEHICLE START-UP THE MGCT INDICATOR LIGHT FLASHES AT THE SAME FREQUENCY AS THE ABS INDICATOR LIGHT, INDICATING A DIAGNOSTIC PHASE OF THE SYSTEM. IN THE ABSENCE OF ERRORS, BOTH INDICATOR LIGHTS TURN OFF AT THE SAME TIME WHEN EXCEEDING 5 km/h (3.11 mph).**

**IN CASE OF ABSENCE OF FLASHING AT START-UP, THE SYSTEM MAY NOT WORKING, PLEASE CONTACT AN AUTHORISED SERVICE CENTRE.**



**WARNING**

IF DISABLED BY THE USER, THE MGCT SYSTEM KEEPS THE STATE OF INACTIVITY ONLY IF THE VEHICLE IS OFF BY USING THE ENGINE STOP SWITCH (RUN-OFF).

**CAUTION**

IT IS EMPHASISED THAT THE RIDING AUXILIARY SYSTEM CANNOT CHANGE THE PHYSICAL LIMITS OF GRIP AND IS NOT A SUBSTITUTE FOR PROPER MANAGEMENT OF POWER, BOTH ON STRAIGHT STRETCHES AND IN TURNS. THEREFORE, IT IS RECOMMENDED TO ALWAYS USE THE VEHICLE WITH THE UTMOST CARE AND IN ACCORDANCE WITH THE REGULATIONS IN FORCE.

**NOTE**

WHEN GOING OVER ROAD JOINTS, RAILS AND/OR ROADS FULL OF POT-HOLES, BRIEF ACTIVATION OF THE MGCT SYSTEM MAY OCCUR. SUCH EVENT APPEARS UNDER NORMAL OPERATION CONDITIONS OF THE VEHICLE.

**CAUTION**

A POOR STATE OF MAINTENANCE OF THE TYRES (PRESSURE TOO LOW OR FLAT TYRES/WEAR) CAN RESULT IN ABNORMAL OPERATION OF THE MGCT SYSTEM.

IN CASE OF REPEATED INTERVENTIONS OF THE MGCT SYSTEM, EVEN ON ROAD SURFACES WITH GOOD GRIP OR SMALL THROTTLE OPENINGS, IT IS NECESSARY TO CHECK FOR WEAR AND/OR THE STATE OF INFLATION OF TYRES FIRST. IF THE PROBLEM PERSISTS, DEACTIVATE THE MGCT SYSTEM AND CONTACT AN AUTHORIZED SERVICE CENTRE.

**CAUTION**

**IN THE EVENT OF MALFUNCTION OF THE BATTERY, THE ABS - MGCT SYSTEM TURNS OFF.**



**IF THE GAP FOR ONE OR BOTH SENSORS IS NOT WITHIN THE TOLERANCE INDICATED BELOW, TAKE THE MOTORCYCLE TO AN Authorised Moto Guzzi Dealer**

**Characteristic****Distance between tone wheel and front sensor**

0.1 - 2.00 mm (0.004 - 0.079 in)

**Distance between tone wheel and rear sensor**

0.1 - 2,00 mm (0.004 - 0.079 in)

**Immobilizer system operation (02\_96, 02\_97, 02\_98)**

For enhanced theft protection, the vehicle is equipped with an electronic immobilizer system that is activated automatically when the ignition key is removed.

Keep the second key in a safe place since it is not possible to make a copy if it gets lost. This would imply replacing numerous parts of the vehicle (besides the locks).

Each key in the grip has an electronic device - transponder - which modulates the radio frequency signal emitted by a special aerial inside the switch when the vehicle is started.

The modulated signal is the "password" by which the appropriate central unit recognises the key and only after this occurs, it allows the engine start-up.

#### CAUTION

**THE IMMOBILIZER SYSTEM CAN MEMORISE UP TO FOUR KEYS.**

**DATA STORAGE CAN ONLY BE PERFORMED BY A DEALER.**

**DATA STORAGE PROCEDURE CANCELS THE EXISTING CODES. THEREFORE, IF A CUSTOMER WANTS TO PROGRAM SOME NEW KEYS, S/HE SHOULD GO TO THE DEALER TAKING ALL THE KEYS S/HE WANTS TO ENABLE.**

In the event the instrument panel detects a fault with the immobilizer system when the key is connected, you will need to enter the user code to start the motorcycle. At the same time the indicator light appears on the instrument panel, the general red warning light will come on.



Once the code has been correctly entered, the error will be displayed on the screen. You can then start up the motorcycle and go immediately to an Authorised **Moto Guzzi** Dealership.

#### CAUTION

**PRESSING OR MOVING ANY CONTROL ON THE LEFT SWITCH CLUSTER, IT IS POSSIBLE TO REMOVE THE ERROR NOTIFICATION SCREEN, BUT THE SCREEN WILL BE VISIBLE AGAIN AFTER ABOUT 10 SECONDS.**

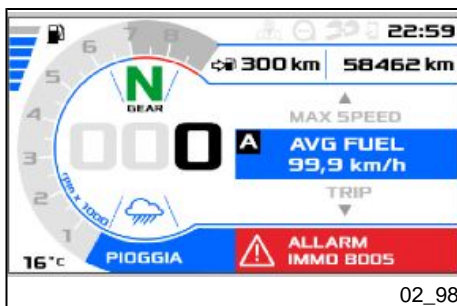

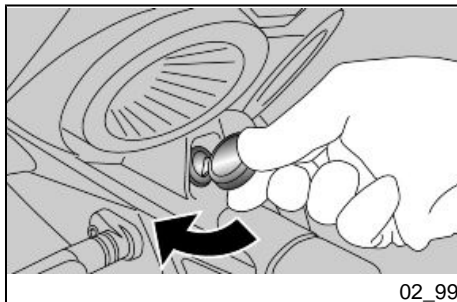

02\_99

### Opening the saddle (02\_99, 02\_100, 02\_101)

- Rest the vehicle on its stand.
- Insert the key in the saddle lock underneath the taillight.
- Turn the key clockwise.

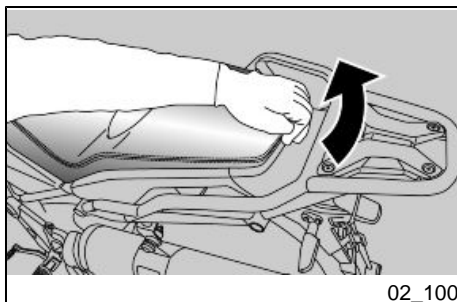

02\_100

- Press down lightly in the centre of the saddle rear seat to release the pin, lift and remove the saddle at the rear.

#### CAUTION

**BEFORE LOWERING AND LOCKING THE SADDLE, MAKE SURE THAT THE IGNITION KEY HAS NOT BEEN FORGOTTEN IN AN UNSUITABLE POSITION UNDER THE SADDLE.**

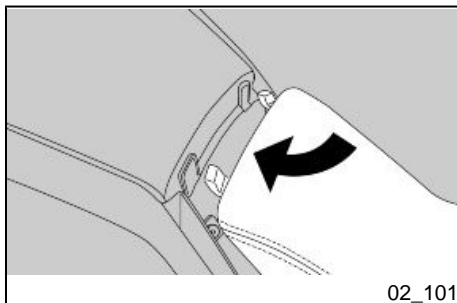

02\_101

#### To lock the saddle:

- Place the saddle's front part in its seat and lower the rear part.
- Press the rear part to trip the lock.



**BEFORE RIDING, MAKE SURE THAT THE SADDLE IS CORRECTLY LOCKED.**

**USB Port (02\_102)**

There is a USB socket on the LH side of the motorcycle, near the digital display.

To use it, remove the protection cap.



**TO AVOID THAT WATER AND/OR HUMIDITY CAN DAMAGE THE USB PLUG, DO NOT CONNECT ANY DEVICES IN CASE OF RAIN.**



**IF A USB DEVICE IS CONNECTED, ENSURE THE CORRECT POSITIONING OF THE CABLE TO AVOID THAT IT WILL BE SMASHED.**

The USB port is active once the key is turned to «ON».

**WARNING**

**PROLONGED USE OF THE PLUG SOCKET MAY RESULT IN PARTIAL DISCHARGE OF THE BATTERY.**

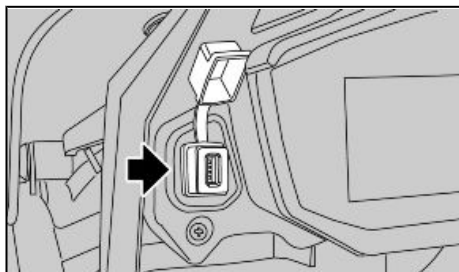

02\_102

**USB PORT**

Output voltage	(5.00+/-0.25) DC
Charging current	1A Max

## Identification (02\_103, 02\_104)

Write down the chassis and engine number in the specific space in this booklet. The chassis number is handy when purchasing spare parts.

### CAUTION



**THE MODIFICATION OF THE IDENTIFICATION CODES IS A SERIOUS PUNISHABLE CRIME. HOWEVER, THE LIMITED WARRANTY FOR NEW VEHICLES WILL BE VOID IF THE VEHICLE IDENTIFICATION NUMBER (VIN) HAS BEEN MODIFIED OR NOT PROMPTLY DETERMINED.**

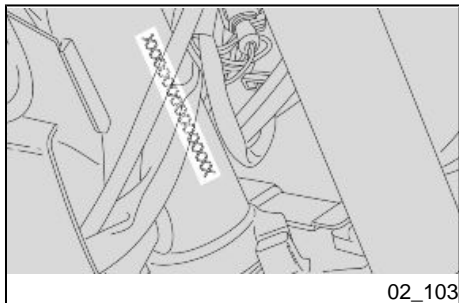

### CHASSIS NUMBER

The chassis number is stamped on the RH side of the headstock.

Chassis No. ....

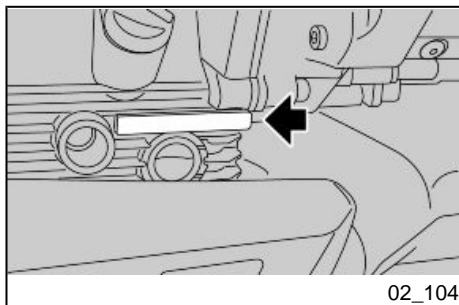

02\_104

### ENGINE NUMBER

The engine number is stamped on the left side, close to the engine oil filler plug.

Engine No. ....

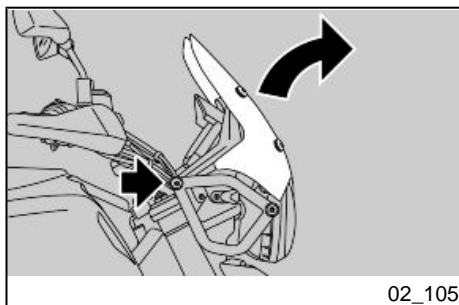

02\_105

### Adjusting the windscreen (02\_105)

The windshield can be manually adjusted as follows:

- Loosen the two screws on both sides.
- Adjust the windshield to the desired position and tighten the two screws.





# V85 TT - V85 TT Travel E5



**Chap. 03**  
**Use**

## Checks (03\_01)

### CAUTION

**BEFORE DEPARTURE, ALWAYS CARRY OUT A PRELIMINARY CHECK OF THE VEHICLE, FOR CORRECT AND SAFE OPERATION. FAILURE TO DO SO MAY LEAD TO SEVERE PERSONAL INJURY OR VEHICLE DAMAGE. DO NOT HESITATE TO CONTACT AN Official Moto Guzzi Dealer IF YOU DO NOT UNDERSTAND HOW SOME CONTROLS WORK OR IF MALFUNCTIONING IS DETECTED OR SUSPECTED. CHECKS DO NOT TAKE LONG AND RESULT IN SIGNIFICANTLY ENHANCED SAFETY.**

This vehicle has been programmed to indicate in real time any operation failure stored in the electronic control unit memory.



Every time the ignition switch is set to 'KEY ON', all the indicator lights come on for about two seconds.

### PRE-RIDE CHECKS

Front and rear disc brake

Check for proper operation. Check brake lever empty travel and brake fluid level. Check for leaks. Check

	brake pads for wear. If necessary top-up with brake fluid.
Throttle grip	Check that the rotation is smooth in both directions and that there is no jamming.
Engine oil	Check and/or top-up as required.
Wheels/ tyres	<p>Check that tyres are in good conditions. Check inflation pressure, tyre wear and potential damage.</p> <p>Remove any possible strange body that might be stuck in the tread design.</p>
Brake levers	<p>Check they function smoothly.</p> <p>Lubricate the joints and adjust the travel if necessary.</p>
Clutch lever	Check correct operation and empty travel. Check the condition of the cable on the handlebar and on the engine. The cable must be replaced if it shows any signs of fraying. Lubricate the joints if necessary.
Steering	Check that the rotation is uniform, smooth and there are no signs of clearance or slackness.
Side stand	Check that it slides smoothly and that it snaps back to its rest position upon spring tension. Lubricate couplings and joints if necessary.

Clamping elements	Check that the clamping elements are not loose.  Adjust or tighten them as required.
Fuel tank	Check level and refill if necessary.  Check the circuit for leaks or obstructions.  Check that the tank cap closes correctly.
Engine stop switch (ON - OFF)	Check function.
Lights, warning lights, horn, rear stop light switch and electrical devices	Check function of horn and lights. Replace bulbs or repair any faults noted.
Tone wheels	Check that the tone wheels are perfectly clean and in good conditions.

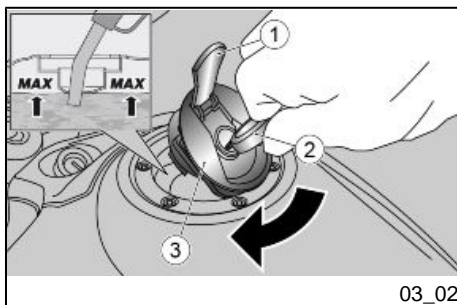

## Refuelling (03\_02, 03\_03)

To refuel:

- Lift the cover (1).
- Insert the key (2) into the fuel tank plug lock.
- Turn the key clockwise, pull and open the fuel filler cap (3).

**CAUTION**

**ALWAYS USE PETROL WITH A MAXIMUM OF 10% BIOETHANOL CONTENT (E10).**

**DO NOT USE PETROL WITH AN ETHANOL CONTENT HIGHER THAN 10%; THIS USE COULD DAMAGE THE FUEL SYSTEM COMPONENTS AND/OR COMPROMISE ENGINE PERFORMANCE.**

**Characteristic****Fuel tank capacity (including reserve)**

23 +/- 1 l (5.06 +/- 0.22 UK gal; 6.08 +/- 0.26 US gal)

**Fuel tank reserve capacity**

5 +/- 0.5 l (1.10 +/- 0.11 UK gal; 1.32 +/- 0.13 US gal)

**NOTE**

**DO NOT FILL THE TANK UP TO THE RIM; FUEL MAXIMUM LEVEL MUST ALWAYS BE BELOW THE LOWER EDGE OF THE FILLER NECK (SEE FIGURE).**

The EN16942 European standard requires the identification of the compatibility of the vehicles with the fuel type by means of a graphic symbol for consumer information. The symbols listed below facilitate the recognition of the correct fuel type to be used on your vehicle. Before refuelling, check the symbols located near the filler neck and compare them with the symbol shown on the filling pump.

**E5:** unleaded gasoline with 5% maximum Ethanol percent.

**E10:** unleaded gasoline with 10% maximum Ethanol percent.

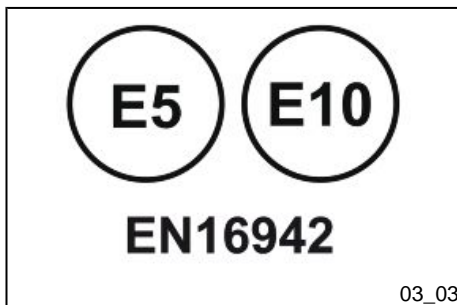

**The label on each pump dispenser shows only one value;** if for example it shows E5 it means that the petrol supplied is unleaded, with 5% ethanol.

**However, the label on the vehicle may show several values.** If, for example, it shows both E5 and E10 values, it means that the vehicle is compatible with gasoline containing maximum 10% Ethanol and thus the Customer may refuel either from a E5 dispenser or from a E10 dispenser (but not from an E85 dispenser).

- Refill.

#### CAUTION



**DO NOT ADD ADDITIVES OR ANY OTHER SUBSTANCES TO THE FUEL.  
WHEN USING A FUNNEL, ENSURE THAT IT IS PERFECTLY CLEAN.**



**DURING REFUELLING AVOID FUEL LEAKAGES, WHICH MAY CAUSE DAMAGE TO THINGS OR PERSONS AND FIRE HAZARD.**

**DURING REFUELLING, AVOID THE USE OF ELECTRIC DEVICES AND/OR MOBILE PHONES, BECAUSE FUEL VAPOURS MAY CAUSE DAMAGE TO OBJECTS AND/OR PERSONAL INJURIES.**

#### **After refuelling:**

- The cap can only be closed if the key (2) is inserted.
- Once the key (2) is inserted, press the cap to close it again.
- Remove the key (2).
- Close the cover (1).



**MAKE SURE THE CAP IS TIGHTLY CLOSED.**

### Rear shock absorbers adjustment (03\_04, 03\_05)

The shock absorber has an adjuster ring (1) in order to regulate the spring preload (2).

#### NOTE

**THE PRE-LOAD OF THE SHOCK ABSORBER CAN BE VARIED ACCORDING TO THE LOAD ON THE VEHICLE (PASSENGER OR HEAVY LOAD).**

#### CAUTION

**DO NOT FORCE THE ROTATION OF THE ADJUSTMENT SCREW BEYOND THE LIMIT STOP IN BOTH DIRECTIONS, IN ORDER TO PREVENT ANY DAMAGE.**

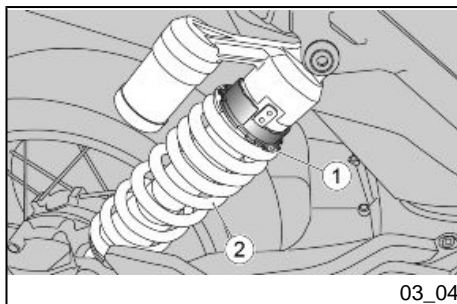

03\_04

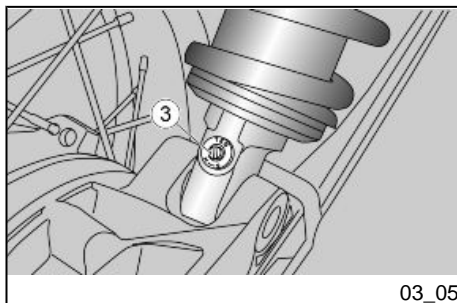

03\_05

An adjuster (3) is located on the bottom part of the shock absorber for rebound damping adjustment.

#### CAUTION

**DO NOT FORCE THE ROTATION OF THE ADJUSTMENT SCREW BEYOND THE LIMIT STOP IN BOTH DIRECTIONS, IN ORDER TO PREVENT ANY DAMAGE.**

### Spring pre-load

By adjusting the spring pre-load, the seat of the spring itself is moved. Carrying out the adjustment, you can decrease or increase the stiffness of the spring and therefore lower or raise the height of the rear of the vehicle. The spring pre-load is essential for the function performed by the rear shock absorbers. If the spring pre-load is not adjusted correctly, no other adjustment will be effective to obtain good shock absorber performance.

### Rebound braking

Rebound braking controls the energy absorption when the shock absorber is in the rebound phase. In other words, rebound braking adjusts the speed at which the shock absorber returns to the normal position after having been compressed.

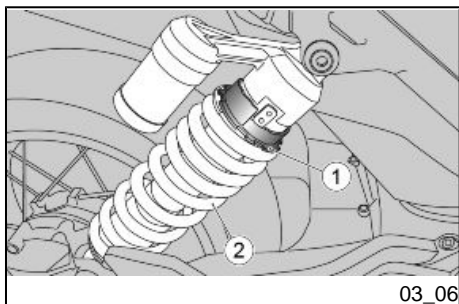

### Rear shock absorbers setting (03\_06, 03\_07)

#### Spring pre-load adjustment

Turn the adjuster ring (1) with a hook spanner to change the shock absorber spring preload (2) setting. Rotate the ring adjuster (1) clockwise to increase the pre-load or anticlockwise to decrease the pre-load.



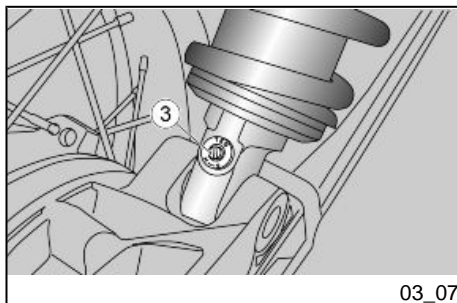

### Rebound braking adjustment

Rebound braking adjustment is carried out by rotating the adjuster (3) located on the bottom part of the shock absorber. Rotate the ring adjuster clockwise to increase rebound braking or anticlockwise to decrease rebound braking.

Follow the instructions given in the tables below for the vehicle setting that best suits the conditions of use.

### **RECOMMENDED SETTING**

<b>TYPE OF ADJUSTMENT</b>	<b>RIDER ONLY</b>	<b>RIDER + LUGGAGE AND TOP BOX OR RIDER + PASSENGER</b>	<b>RIDER + PASSENGER + LUGGAGE AND TOP BOX</b>
PRELOAD (RING NUT)	1 bar	3 bars	7 bars
HYDRAULIC DAMPING (ADJUSTER SCREW) - FROM FULLY CLOSED (*) OPEN (**)	2 turns	1 turn	0.5 turns

(\*) = clockwise

(\*\*) = anticlockwise

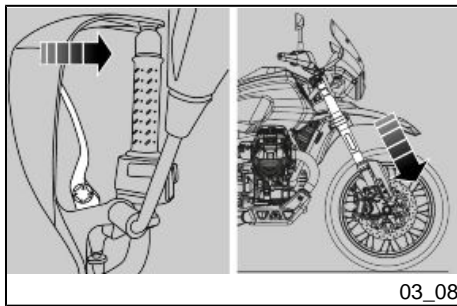

03\_08

### Front fork adjustment (03\_08, 03\_09)

Operating the front brake lever, press the handlebar repeatedly to send the fork fully down. The shock absorber should compress and extend smoothly with no signs of oil leakage on the stanchions.

Check the tightening of all the elements and the correct operation of the front and rear suspension joints.

#### CAUTION

**TO HAVE THE FRONT FORK OIL AND OIL SEALS REPLACED, CONTACT AN Authorised Moto Guzzi Dealer.**

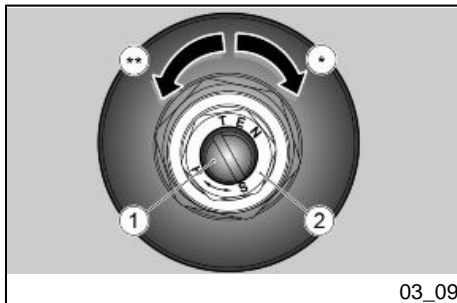

03\_09

The front suspension consists of a hydraulic fork connected to the headstock by means of two plates.

The right stem of the fork has an upper nut (2) for adjusting the spring pre-load and an upper adjustment screw (1) for adjusting the hydraulic braking in rebound.



**DO NOT FORCE THE ROTATION OF THE ADJUSTMENT SCREW BEYOND THE LIMIT STOP IN BOTH DIRECTIONS, IN ORDER TO PREVENT ANY DAMAGE.**

**WHEN SPRING PRE-LOAD IS INCREASED, REBOUND DAMPING MUST ALSO BE INCREASED TO PREVENT EXCESSIVE SUSPENSION KICKBACK WHEN RIDING.**

The standard front fork setting is adjusted to suit most high and low speed riding conditions, whether the vehicle is partially or fully loaded.

However, the setting can be modified for specific needs according to vehicle use.

**CAUTION**

FOR THE CORRECT SETTING PARAMETERS, READ THE PARAGRAPH "SETTING THE FRONT FORK" CAREFULLY.

IF NECESSARY, CONTACT AN Authorised Moto Guzzi Dealer.

**Front fork setting (03\_10, 03\_11)**

TO COUNT THE NUMBER OF CLICKS AND/OR REVOLUTIONS OF ADJUSTMENT SETTINGS ALWAYS START FROM THE MOST RIGID SETTING (WHOLE CLOCKWISE ROTATION OF THE SETTING).

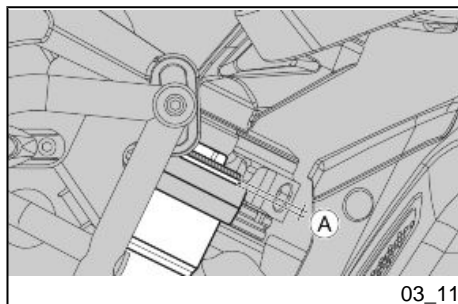
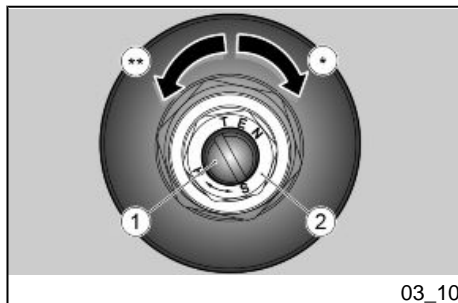

## RECOMMENDED SETTING

TYPE OF ADJUSTMENT	RIDER ONLY	RIDER + LUGGAGE AND TOP BOX OR RIDER + PASSENGER	RIDER + PASSENGER + LUGGAGE AND TOP BOX
PRELOAD (NUT) - FROM FULLY CLOSED (*) OPEN (**)	1 bar	1 bar	1 bar
HYDRAULIC DAMPING (ADJUSTER SCREW) - FROM FULLY CLOSED (*) OPEN (**)	10 clicks	10 clicks	10 clicks
STEMS (A) (***) PROTRUSION FROM TOP PLATE (EXCLUDING COVER)	1 notch	1 notch	1 notch

(\*) - Clockwise

(\*\*) - Anticlockwise

(\*\*\*) - this type of adjustment may only be made by an **Authorised Moto Guzzi Dealer**.

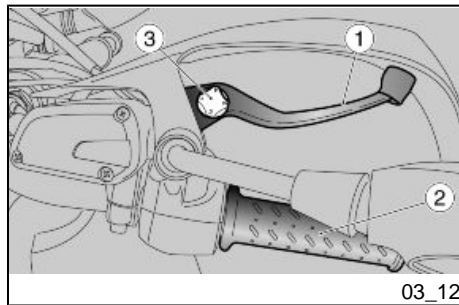

### Justering af greb til forbremse (03\_12)

It is possible to adjust the distance between the end of the lever (1) and the grip (2), turning the adjuster (3).

- Push the control lever (1) forwards and turn the adjuster (3) until the lever (1) is at the desired distance.
- Turning the adjuster anticlockwise, the lever (1) gets closer to the grip (2).

#### CAUTION

**IF THE FRONT BRAKE LEVER MUST BE REMOVED, CHECKED AND CHANGED BY AN Authorised Moto Guzzi Dealership**

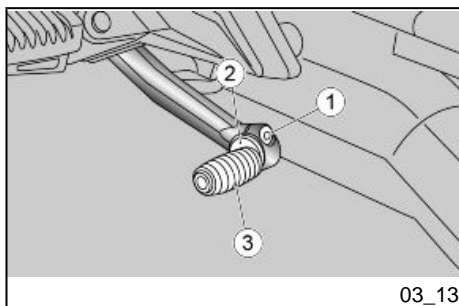

### Rear brake pedal adjustment (03\_13)

The control levers are positioned ergonomically when the vehicle is being assembled.  
if necessary, it is possible to customise the position of the levers.

- Rest the vehicle on its stand.
- Partially undo the screw (1).
- Turn the cam (2) finding the best position for the pedal (3).
- Tighten the screw (1) and check the cam is stable in position.

#### CAUTION

**TO ADJUST THE BRAKE LEVER CLEARANCE, CONTACT AN Authorised Moto Guzzi Dealer.**

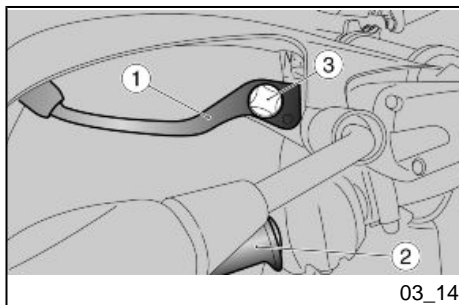

### Clutch lever adjustment (03\_14, 03\_15, 03\_16)

It is possible to adjust the distance between the end of the lever (1) and the grip (2), turning the adjuster (3).

- Push the control lever (1) forwards and turn the adjuster (3) until the lever (1) is at the desired distance.
- Turning the adjuster anticlockwise, the lever (1) gets closer to the grip (2).

Adjust the clutch when the engine stops or the vehicle tends to move forward even when clutch lever is operated and the gear engaged, or if the clutch "slides", resulting in acceleration delay considering the engine revs.

- In order to maintain a correct tension and an optimal clutch operation, it is necessary to check and if necessary provide tension to the cable:
- Urban use every 1,000 km (621.37 mi)

- Extra urban use every 5,000 km (3,106.86 mi)
- In any case, every time you detect that the clutch has disengaged before the standard factory setting.

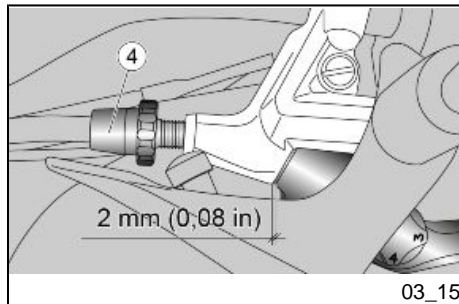

To adjust, do the following:

- Turn the set screw (4) with straight handlebar until the empty travel corresponding to the fixed abutment on the handlebar is 2 mm (0.08 in)
- Push the clutch control lever on the gearbox housing towards the rear wheel
- Pull the clutch control lever placed on the gearbox towards the opposite side (as in point 2) checking that the cable is not tightened.
- During the previous operation, check that the cable lug turns freely around its axis, regarding the clutch lever
- Tighten the set screw (4)
- If after the adjustment in point 1 it is not possible to ascertain the condition of "point 4", contact an Authorised **Moto Guzzi Dealer** to verify the proper operation of the clutch control.
- If the adjuster stroke (6) is not sufficient to ensure the required clearance, contact an Authorised **Moto Guzzi Dealer**

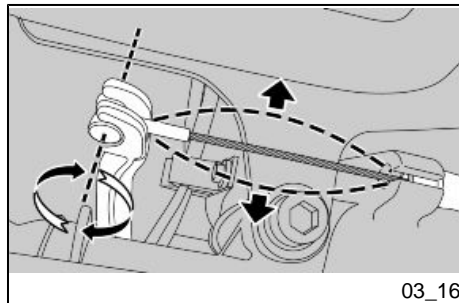

## Running in

Running in is essential to ensure the durability of the vehicle. During the first 1,500 Km (932.06 mi), observe the following rules to ensure the reliability and performance of the vehicle throughout its lifetime:

- Avoid full throttle starts and hard acceleration;

- Avoid exceeding 4500 rpm;
- Avoid hard or prolonged braking;
- Do not ride for prolonged periods at sustained high speed; preferably ride the motorcycle on varied routes with frequent, gentle acceleration and deceleration;
- Ride prudently to gradually gain familiarity with the motorcycle, testing progressively higher throttle apertures only as you gain confidence

**CAUTION**

**THIS VEHICLE IS EQUIPPED WITH A SINGLE DISC DRY CLUTCH. IN CERTAIN CONDITIONS, THE CLUTCH MAY EMIT A SLIGHT AND DISTINCTIVE ODOUR OF CLUTCH MATERIAL. THIS IS NORMAL AND IS NOT INDICATIVE OF A FAULT.**

**CAUTION**

**THE FULL PERFORMANCE OF THE VEHICLE IS ONLY AVAILABLE AFTER THE SERVICE AT THE END OF THE RUNNING IN PERIOD.**



**TO PREVENT THE RISK OF INJURY TO YOURSELF OR OTHERS AND/OR DAMAGE TO THE VEHICLE, TAKE THE YOUR MOTORCYCLE TO AN AUTHORISED Moto Guzzi DEALER AT THE SPECIFIED MILEAGE INTERVALS TO HAVE THE CHECKS LISTED IN THE MAINTENANCE SCHEDULE TABLE CARRIED OUT.**

### **Starting up the engine (03\_17, 03\_18, 03\_19)**

**This vehicle is extremely powerful and must be used carefully and driven with caution and respect for its power and potential.**

**Do not place objects inside the top fairing (between the handlebar and the instrument cluster), as this may impede the movements of the handlebar and obstruct visibility of the instruments.**



**EXHAUST FUMES CONTAIN CARBON MONOXIDE, AN EXTREMELY HARMFUL SUBSTANCE IF INHALED.**

**NEVER START THE ENGINE IN A CLOSED OR INSUFFICIENTLY VENTILATED SPACE.**



**FAILURE TO OBSERVE THIS WARNING COULD LEAD TO UNCONSCIOUSNESS AND EVEN DEATH DUE TO SUFFOCATION.**

#### **CAUTION**

**WITH THE SIDE STAND LOWERED, THE ENGINE MAY ONLY BE STARTED WITH THE GEARBOX IN NEUTRAL. IF YOU ATTEMPT TO ENGAGE THE GEAR, THE ENGINE WILL STOP.**

**WITH THE SIDE STAND RETRACTED, THE ENGINE MAY BE STARTED WITH THE GEARBOX IN NEUTRAL OR WITH THE GEAR ENGAGED AND THE CLUTCH LEVER OPERATED.**

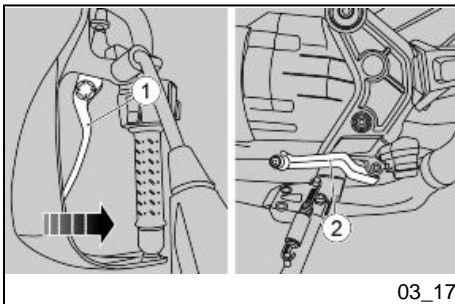

- Get on the motorcycle, assuming the correct driving posture.
- Make sure that the side stand has been fully retracted.
- Operate the front or rear brake (or both).
- Operate the clutch lever (1) and make sure that the transmission (2) is in neutral.



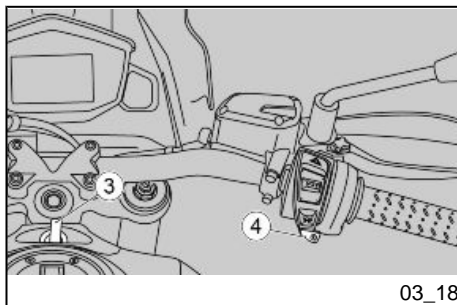

03\_18

- Turn the ignition switch (3) to "ON".

At this stage:

- The starting screen will be displayed on the digital display for about 2 seconds and then the screen with the standard parameters will appear.
- All the indicator lights on the instrument panel will come on for about 2 seconds.
- Press the starter button (4) once only.
- With the engine running normally, all the instant parameters will appear on the digital display.



**IF THE LOW FUEL WARNING LIGHT ON THE DASHBOARD TURNS ON, REFUEL THE VEHICLE AT ONCE.**



**INTENSE USE/ON THE TRACK IN RESERVE CAN DAMAGE THE ENGINE.**



**ON NEW VEHICLES, THE SHIFT LIGHT THRESHOLD IS SET TO 5200 RPM. RAISE THE THRESHOLD GRADUALLY UNTIL YOU HAVE BECOME FAMILIAR WITH THE VEHICLE AND THE RUN-IN HAS BEEN COMPLETED.**



A FEW SECONDS AFTER ENGINE START-UP, THE START-UP BUTTON ACTS AS A RIDING MODE CHANGE BUTTON.



IF THE GENERAL WARNING LIGHT ON THE INSTRUMENT PANEL COMES ON, IT MEANS THAT THE CONTROL UNIT HAS ENCOUNTERED A FAULT AND YOU MUST CONTACT AN Authorised Moto Guzzi Dealer.



DO NOT SET OFF SUDDENLY WHEN THE ENGINE IS COLD. RIDE AT LOW SPEED FOR SEVERAL KILOMETRES. THIS WILL ALLOW THE ENGINE TO WARM UP AND REDUCE POLLUTING EMISSIONS AND FUEL CONSUMPTION.

### Moving off / riding (03\_20, 03\_21, 03\_22)

#### CAUTION

THE ECU INSTALLED ON THIS MOTORCYCLE COMPENSATES FOR INCREASED ELECTRIC POWER CONSUMPTION BY TEMPORARILY RAISING THE IDLE SPEED; VARIATIONS IN ENGINE SPEED WITHIN THIS RANGE ARE THEREFORE NORMAL.



**IF THE LOW FUEL WARNING LIGHT ON THE INSTRUMENT PANEL TURNS ON, REFUEL THE VEHICLE AT ONCE.**

#### **WARNING**

**IF THE MOTORCYCLE TURNS OFF ACCIDENTALLY THE ECU ALLOWS A RESTART WITHIN THE NEXT 5 SECONDS. ONCE THIS PERIOD OF TIME HAS PASSED THE ECU WILL PREVENT STARTING FOR ANOTHER 3 SECONDS AND ONLY THEN WILL IT BE POSSIBLE TO START THE MOTORCYCLE.**

#### **CAUTION**

**WHEN TRAVELLING WITHOUT PASSENGERS, MAKE SURE THE PASSENGER FOOTRESTS ARE FOLDED UP.**

#### **CAUTION**

**PASSENGERS MUST BE SUITABLY INSTRUCTED ON HOW TO BEHAVE TO PREVENT DANGEROUS SITUATIONS WHEN RIDING.**

**BEFORE SETTING OFF, MAKE SURE THE STAND HAS BEEN COMPLETELY RETRACTED TO ITS POSITION.**

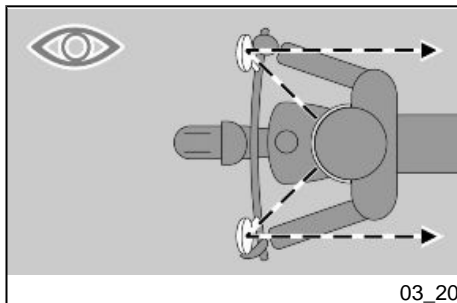

#### **To start:**

- Turn on the engine.
- Adjust the inclination of the rear-view mirrors to ensure proper visibility.

#### **CAUTION**



**WITH THE VEHICLE AT STANDSTILL, PRACTICE USING THE REAR-VIEW MIRRORS. THE MIRRORS ARE CONVEX, SO OBJECTS MAY SEEM FARTHER AWAY THAN THEY REALLY ARE. THESE MIRRORS OFFER A WIDE-ANGLE**

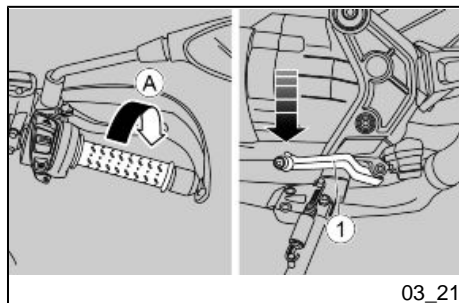

**VIEW AND ONLY EXPERIENCE HELPS YOU JUDGE THE DISTANCE SEPARATING YOU AND THE VEHICLE BEHIND.**

- With a closed throttle grip (Pos. A) and the engine idling, pull the clutch lever.
- Push the gearbox lever (1) downward to select the first gear.
- Release the clutch lever (activated during start-up).

#### CAUTION

**WHEN TURNING OFF THE VEHICLE, DO NOT RELEASE THE CLUTCH TOO QUICKLY OR SUDDENLY, AS THIS COULD CAUSE THE ENGINE TO STOP OR THE VEHICLE TO REAR UP ON THE BACK WHEEL. DO NOT ACCELERATE SUDDENLY WHEN RELEASING THE CLUTCH FOR THE SAME REASON.**

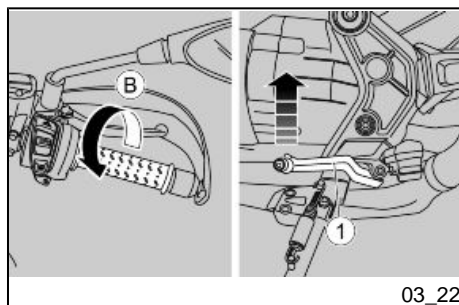

- Slowly release the clutch lever and accelerate by slightly turning the throttle grip at the same time (Pos. B).

The vehicle starts moving forward.

- For the first kilometres travelled, limit the speed in order to warm up the engine.
- Speed up by gradually turning the throttle grip (Pos. B) without exceeding the recommended revs.



**RIDE IN THE CORRECT GEAR AND SPEED FOR THE CONDITIONS.  
DO NOT OPERATE THE THROTTLE GRIP ABRUPTLY.**

- Release the throttle grip (Pos. A), operate the clutch lever and lift the gear control lever (1), release the clutch lever and accelerate.
- Repeat the last two operations and engage a higher gear.



**IT IS SUGGESTED TO GO UP TO A HIGHER GEAR THAN TO A LOWER GEAR:**

- When riding downhill and under braking, using engine compression to increase braking power.
- When going uphill, when the engaged gear does not suit the speed (high gear, moderate speed) and the number of engine revs falls.

#### **CAUTION**

**DOWNSHIFT ONE GEAR AT A TIME; WHEN SHIFTING TO A LOWER GEAR, DOWNSHIFTING MORE THAN ONE GEAR AT A TIME COULD OVERREV THE ENGINE; THAT IS, THE MAXIMUM RPM VALUE PERMITTED FOR THE ENGINE COULD BE EXCEEDED.**

- Release the throttle grip (Pos. A).
- If necessary, pull the brake levers gently and reduce speed.
- Operate the clutch lever and lower the gearshift lever (1) to engage a lower gear.
- Release the brake levers when it is operated.
- Release the clutch lever and accelerate moderately.



**IN ORDER TO AVOID CLUTCH OVERHEATING, SHUT THE ENGINE OFF AS SOON AS POSSIBLE ONCE THE VEHICLE HAS STOPPED AND AT THE SAME TIME THE GEAR IS ENGAGED AND THE CLUTCH LEVER OPERATED.**



**OPERATE THE FRONT OR THE REAR BRAKE ONLY SIGNIFICANTLY REDUCES THE BRAKING FORCE OF THE VEHICLE.**

**WHEN STOPPING UPHILL, DECELERATE COMPLETELY AND ONLY USE THE BRAKES TO MAINTAIN THE VEHICLE IN THE STOPPED POSITION.**

**USING THE ENGINE TO KEEP THE MOTORCYCLE STOPPED COULD CAUSE THE CLUTCH TO OVERHEAT. BRAKING CONTINUOUSLY WHEN DRIVING DOWNHILL COULD CAUSE THE BRAKE PADS TO OVERHEAT, WHICH REDUCES BRAKING AND LIMITS BRAKING POWER.**

**IT IS RECOMMENDED TO USE THE ENGINE COMPRESSION, DOWNSHIFTING AND USING BOTH BRAKES INTERMITTENTLY.**

**WHEN DRIVING DOWNHILL, NEVER RIDE WITH THE ENGINE TURNED OFF.**

**WHEN RIDING ON WET SURFACES OR SURFACES WITH POOR GRIP (SNOW, ICE, MUD, ETC.) USE MODERATE SPEED, AVOID SUDDEN BRAKING OR MANOEUVRES THAT MAY CAUSE TO A LOSS OF TRACTION AND POSSIBLY TO A FALL OR CRASH.**

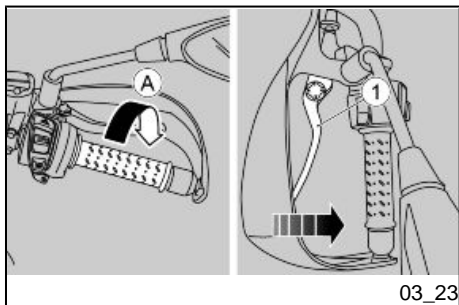

### Stopping the engine (03\_23)

- Release the throttle grip (Pos. A), brake gradually and simultaneously downshift to slow down.

**Once the speed is reduced, before stopping the vehicle:**

- Operate the clutch lever (1) so that engine does not shut off.

**When the vehicle is at a standstill:**

- Set the gearshift lever to neutral ("N" appears on digital display with green "N" indicator light on).
- Release the clutch lever (1).
- While at a temporary halt, keep at least one of the vehicle brakes held.

**CAUTION**

**WHENEVER POSSIBLE, AVOID ROUGH BRAKING, SUDDEN DECELERATION AND BRAKING IN EXCESS.**

**Parking**

It is very important to select an adequate parking spot, in compliance with road signals and the guidelines described below.

**CAUTION**

**PARK ON SAFE AND LEVEL GROUND TO PREVENT THE MOTORCYCLE FROM FALLING.**

**DO NOT LEAN THE VEHICLE AGAINST A WALL OR LAY IT ON THE GROUND.**

**ENSURE THAT THE VEHICLE AND, IN PARTICULAR, PARTS OF THE VEHICLE WHICH MAY BECOME HOT (ENGINE, EXHAUST SYSTEM, BRAKE DISCS) ARE NOT A HAZARD TO PERSONS OR CHILDREN. DO NOT LEAVE YOUR VEHICLE UNATTENDED WITH THE ENGINE ON OR THE KEY IN THE IGNITION SWITCH.**

**CAUTION**

**IF THE VEHICLE FALLS OR IS ON A STEEP INCLINE FUEL CAN LEAK.**

**FUEL USED TO DRIVE INTERNAL COMBUSTION ENGINES IS HIGHLY FLAMMABLE AND CAN BECOME EXPLOSIVE UNDER CERTAIN CONDITIONS.**



**DO NOT REST THE RIDER OR PASSENGER WEIGHT ON THE SIDE STAND.**

## Catalytic silencer

The vehicle has silencers with a "platinum - palladium - rhodium three-way" metal catalytic converter.

This device oxidises the CO (carbon monoxide) producing carbon dioxide, and the UHC (unburned hydrocarbons) producing water vapour and reduces NOx (nitrogen oxide) producing oxygen and nitrogen present in the exhaust fumes.



**DO NOT PARK THE VEHICLE NEAR DRY BRUSHWOOD OR IN PLACES EASILY ACCESSIBLE BY CHILDREN BECAUSE THE CATALYTIC CONVERTER REACHES HIGH TEMPERATURES DURING VEHICLE OPERATION; FOR THIS REASON, PAY UTMOST ATTENTION AND DO NOT TOUCH IT UNTIL IT HAS COMPLETELY COOLED DOWN.**



**DO NOT USE LEADED PETROL AS IT CAUSES IRREPARABLE DAMAGE TO THE CATALYTIC CONVERTER.**

Vehicle owners are warned that the law may prohibit the following:

- the removal of any device or element belonging to a new vehicle or any other action by anyone leading to render it non-operating, if not for maintenance, repair or replacement reasons, in order to control noise emission before the sale or delivery of the vehicle to the ultimate buyer or while it is used;
- using the vehicle after that device or element has been removed or rendered non-operating.

Check the exhaust silencer and the silencer pipes, ensuring there are no signs of penetrative corrosion and that the exhaust system works properly.

If the noise produced by the exhaust system increases, get immediately in touch with the Dealer or with a Moto Guzzi authorised repair shop.



**NOTE**

**DO NOT TAMPER WITH THE EXHAUST SYSTEM.**

**Stand (03\_24, 03\_25)**

**BEFORE SETTING OFF, MAKE SURE THE STAND HAS BEEN COMPLETELY RETRACTED TO ITS POSITION.**

**DO NOT REST THE RIDER OR PASSENGER WEIGHT ON THE SIDE STAND.**



**THE SIDE STAND MUST ROTATE FREELY. IF NECESSARY GREASE THE JOINT.**

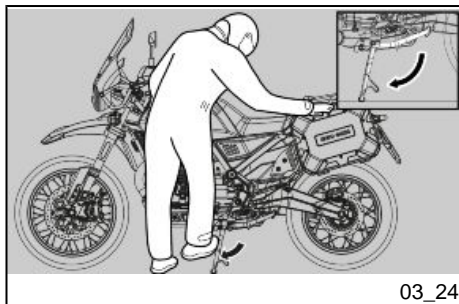

03\_24

**SIDE STAND**

If the stand has been folded up for any manoeuvre (for example, when the vehicle is in motion), place the vehicle on the stand again as follows:

- Grasp the left grip and put the right hand on the upper rear part of the vehicle.
- Push the side stand with your right foot to fully extend the stand.
- Lean the vehicle until the stand touches the ground.
- Turn the handlebar fully leftwards.

**CAUTION**

**MAKE SURE THE VEHICLE IS STABLE.**

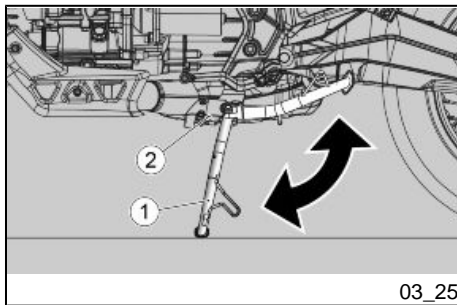

A safety switch (2) is installed on the side stand (1) to inhibit ignition or to stop the engine when a gear is engaged and the side stand (1) is lowered.

**CHECK THAT THE AREA AROUND THE SWITCH IS NOT DIRTY. CLEAN THE AREA IF NECESSARY AND CHECK ON THE INSTRUMENT PANEL THAT THE INDICATOR LIGHT COMES ON WHEN THE STAND IS LOWERED.**

**IF THE SIDE STAND INDICATOR LIGHT DOES NOT COME ON WHEN THE STAND IS LOWERED EVEN AFTER CLEANING, CONTACT AN Authorised Moto Guzzi Dealer.**

## Suggestion to prevent theft

### CAUTION

**WHEN USING A DISC LOCKING DEVICE, PAY UTMOST ATTENTION TO REMOVE IT BEFORE RIDING. FAILURE TO OBSERVE THIS WARNING MAY CAUSE SERIOUS DAMAGE TO THE BRAKING SYSTEM AND ACCIDENTS WITH CONSEQUENT PHYSICAL INJURIES OR EVEN DEATH.**

NEVER leave the ignition key in the lock and always use the steering lock. Park the vehicle in a safe place such as a garage or a place with guards. Whenever possible, use an additional anti-theft device. Make sure all vehicle documents are in order and the road tax paid. Write down your personal details and telephone number on this page to help identifying the owner in case of vehicle retrieval after a theft.

LAST NAME: .....

NAME: .....

ADDRESS: .....

TELEPHONE NO.: .....

**WARNING**

**IN MANY CASES, STOLEN VEHICLES CAN BE IDENTIFIED BY DATA IN THE USE / MAINTENANCE BOOKLET.**

**Safe driving**

Some simple tips are provided below that will enable you to use your motorcycle on a daily basis in greater safety and peace of mind. Your mechanical knowledge and ability are the foundation for safe driving. We recommend trying out the motorcycle in traffic-free zones to familiarise with it.

1. Before riding off, remember to put the helmet on and fasten it correctly.
2. Slow down and drive carefully over bumpy roads.
3. After driving over a long stretch of wet road without using the brakes, braking will not be as efficient the first time/s you use them again. When driving under conditions like this, you should brake periodically.
4. Although the vehicle is equipped with an ABS system, pay attention when braking on wet surfaces, on dirt or on a slippery road surface.
5. Avoid riding off by mounting the scooter when it is resting on its support.
6. When riding on roads covered with sand, mud, snow mixed with salt, etc. We recommend cleaning the brake discs frequently with a non-corrosive detergent in order to prevent corrosive particles from building up in the holes, which may cause early brake pad wear.

**CAUTION**

**TO ALLOW THE QUICK REACHING OF THE PERFECT GRIP OF NEW TYRES AT THE FIRST MILEAGE, IT IS RECOMMENDED A PARTICULARLY CAREFUL GUIDE OF THE MOTORCYCLE, AVOIDING SUDDEN STEERING OR VIOLENT ACCELERATION AND BRAKING.**

### CAUTION

ALWAYS RIDE WITHIN YOUR LIMITS. RIDING UNDER THE INFLUENCE OF ALCOHOL OR OTHER DRUGS AND CERTAIN MEDICINES IS EXTREMELY DANGEROUS.

### CAUTION

ANY ELABORATION THAT MODIFIES THE VEHICLE'S PERFORMANCES, SUCH AS TAMPERING WITH ORIGINAL STRUCTURAL PARTS IS STRICTLY FORBIDDEN BY LAW, AND RENDERS THE MOTORCYCLE NO LONGER CONFORMING TO THE APPROVED TYPE AND DANGEROUS FOR RIDING.

### CAUTION

DO NOT ADJUST THE MIRRORS WHILE DRIVING. THIS COULD CAUSE YOU TO LOOSE CONTROL OF THE MOTORCYCLE.

### CAUTION

STOP THE VEHICLE MAINLY USING THE FRONT BRAKE. THE REAR BRAKE MUST ONLY BE USED TO BALANCE THE BRAKING EFFECT, AND ONLY TOGETHER WITH THE FRONT BRAKE.

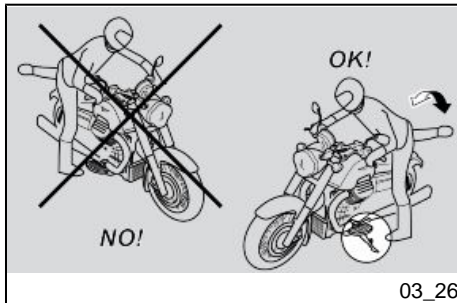

### Basic safety rules (03\_26, 03\_27, 03\_28, 03\_29, 03\_30)

The following recommendations should receive your maximum attention, because they are provided to increase your safety, and decrease damage to people, things and vehicles, in the case of a fall of the rider or passenger from the vehicle and/or from the fall or overturning of the vehicle.

Mounting and dismounting the vehicle should always be performed with total freedom of movement and with the hands free of all objects. (i.e.- objects, helmet, gloves, or glasses).

Mount and dismount only on the left side of the vehicle, and only with the side stand lowered.

The stand is designed to support the weight of the vehicle and a small additional weight, which does not include the rider and passenger.

Mounting into driving position, with the side stand in place, is permitted only to prevent the possibility of the vehicle falling or overturn, and does not indicate the possibility for the rider and passenger's weight to be placed on the side stand.

During mounting and dismounting the vehicle's weight can cause a loss of balance, with consequent loss of equilibrium and the possibility of falling or overturning.

#### CAUTION

**THE RIDER SHOULD ALWAYS BE THE FIRST TO MOUNT AND THE LAST TO DISMOUNT FROM THE VEHICLE, AND SHOULD CONTROL THE STABILITY AND EQUILIBRIUM OF THE VEHICLE WHILE THE PASSENGER IS MOUNTING AND DISMOUNTING**

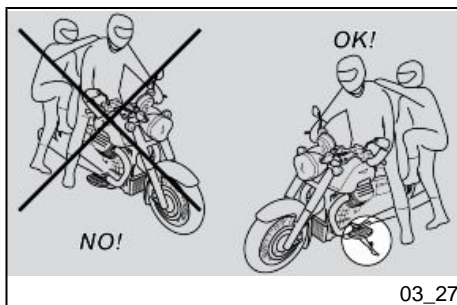

In any case, the passenger should mount and dismount the vehicle using caution to avoid causing the vehicle or the rider to lose balance.

#### CAUTION

**THE RIDER TO INSTRUCT THE PASSENGER ABOUT THE PROPER WAY TO MOUNT AND DISMOUNT FROM THE VEHICLE.**

**THE VEHICLE INCLUDES PASSENGER FOOTRESTS WHICH SHOULD BE USED DURING MOUNTING AND DISMOUNTING. THE PASSENGER SHOULD ALWAYS USE THE LEFT FOOTREST FOR MOUNTING AND DISMOUNTING FROM THE VEHICLE.**

**DO NOT DISMOUNT OR EVEN ATTEMPT TO DISMOUNT BY JUMPING OR STRETCHING OUT YOUR LEG IN ORDER TO TOUCH THE GROUND. IN BOTH CASES THE STABILITY AND EQUILIBRIUM OF THE VEHICLE COULD BE COMPROMISED.**

**CAUTION**

**BAGGAGE OR OBJECTS ATTACHED TO THE REAR PART OF THE VEHICLE CAN CREATE AN OBSTACLE DURING MOUNTING AND DISMOUNTING FROM THE VEHICLE.**

**IN ALL CASES, THINK AHEAD AND MOVE YOUR RIGHT LEG CAREFULLY, AS IT WILL HAVE TO AVOID AND CLEAR THE REAR PART OF THE VEHICLE (INCLUDING BAGGAGE AND THE TAIL FAIRING) WITHOUT CAUSING LOSS OF BALANCE.**

**NOTE**

**BEFORE SETTING OFF, MAKE SURE THE CASES ARE CLOSED AND ATTACHED CORRECTLY TO THE VEHICLE.**

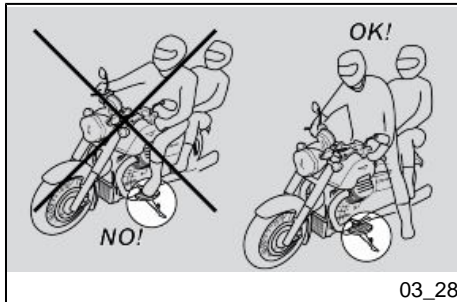

**THE CASES SHOULD NOT BE USED AS A SUPPORT AND HANDLES MUST NOT BE USED AS A GRIP FOR THE PASSENGER.**

**MOUNTING**

- Grip the handlebar properly and mount the vehicle without placing your weight upon the side stand.

**CAUTION**

**IN THE CASE THAT YOU ARE NOT ABLE TO REST BOTH FEET ON THE GROUND, PUT THE RIGHT FOOT ON THE GROUND, (IN THE CASE OF A LOSS OF BALANCE THE LEFT SIDE IS "PROTECTED" BY THE SIDE STAND) AND KEEP YOUR LEFT FOOT READY TO BE POSITIONED.**

- Place both feet on the ground and straighten the vehicle into the driving position, always maintaining its equilibrium.

**CAUTION**

**THE RIDER SHOULD NOT OPEN OR TRY TO OPEN THE PASSENGER FOOTRESTS FROM THE RIDER'S SEAT, AS IT COULD COMPROMISE THE STABILITY AND EQUILIBRIUM OF THE VEHICLE.**

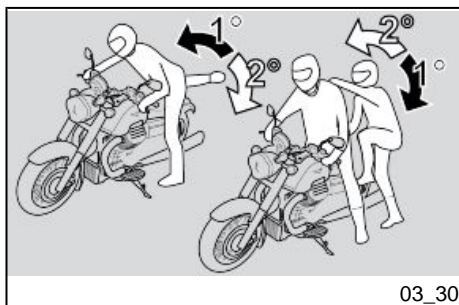
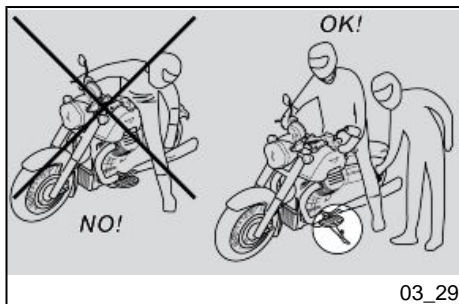

- Extract the two footrests for the passenger.
- Instruct the passenger on how to get on the vehicle.
- Use the left foot to completely retract the side stand.

**DISMOUNTING**

- Choose a parking spot.
- Turn-off the vehicle.



**MAKE SURE THAT THE GROUND ON WHICH THE MOTORCYCLE IS PARKED IS FIRM, EVEN AND FREE OF OBSTACLES.**

- Use the heel of your left foot to completely open the side stand.

**CAUTION**

**IN THE CASE THAT YOU ARE NOT ABLE TO REST BOTH FEET ON THE GROUND, PUT THE RIGHT FOOT ON THE GROUND, (IN THE CASE OF A LOSS OF BALANCE THE LEFT SIDE IS "PROTECTED" BY THE SIDE STAND) AND KEEP YOUR LEFT FOOT READY TO BE POSITIONED.**

- Place both feet on the ground and keep the vehicle balanced in the driving position.
- Instruct the passenger on how to get down from the vehicle.



**RISK OF FALLING OR OVERTURNING.**

**MAKE SURE THAT THE PASSENGER HAS DISMOUNTED FROM THE VEHICLE.  
DO NOT PLACE YOUR WEIGHT UPON THE SIDE STAND.**

- Lean the motorcycle until the stand touches the ground.
- Correctly grip the handlebar, and dismount from the vehicle.
- Turn the handlebar completely to the left.
- Place the passenger footrest in its place.

**CAUTION**



**MAKE SURE THE VEHICLE IS STABLE.**

**Load (03\_31, 03\_32, 03\_33, 03\_34, 03\_35)**

**SIDE CASE**

**WARNING**



**DO NOT LOAD MORE THAN 5 kg (11 lb) PER CASE, AS AN EXCESSIVE LOAD  
MAY DAMAGE IT.**

**CAUTION**

**THE MAXIMUM SPEED ALLOWED WITH THE CASES INSTALLED IS 160 km/h  
(100 MPH).**



**NOTE**

**AN EXAGGERATED VOLUME INSIDE THE CASE MAY COMPROMISE THE IMPERMEABILITY OF THE CASE.**

**NOTE**

**BEFORE SETTING OFF, MAKE SURE THE CASES ARE CLOSED AND ATTACHED CORRECTLY TO THE VEHICLE.**



**THE CASES SHOULD NOT BE USED AS A SUPPORT AND HANDLES MUST NOT BE USED AS A GRIP FOR THE PASSENGER.**

**OPENING THE LID****NOTE**

**THE OPERATIONS BELOW REFER TO A SINGLE CASE BUT APPLY TO BOTH.**

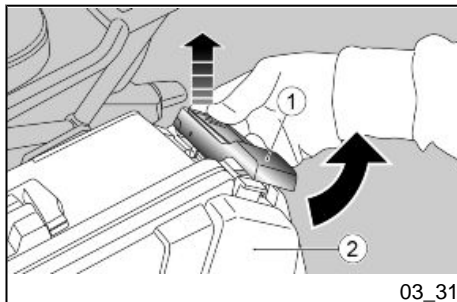

- Lift the locking levers (1) backward and then release them from the lid (2).

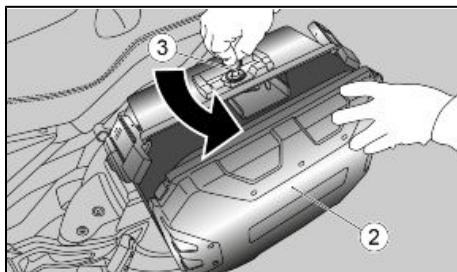

03\_32

- Insert the key (3) in the lock of the case and turn it anti-clockwise to open the lid (2).

**NOTE**

**THE KEY USED FOR OPENING THE CASES CAN ONLY BE REMOVED WHEN THE LOCK IS LOCKED.**

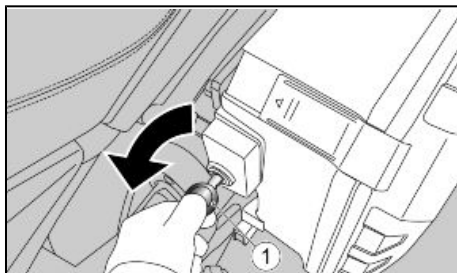

03\_33

**SIDE CASE REMOVAL**

- Insert the key (1) in the lock of the case and turn it anti-clockwise in order to release it.

**NOTE**

**THE KEY USED FOR THE RELEASE AND REMOVAL OF THE CASES CAN ONLY BE REMOVED WHEN THE LOCK IS LOCKED.**

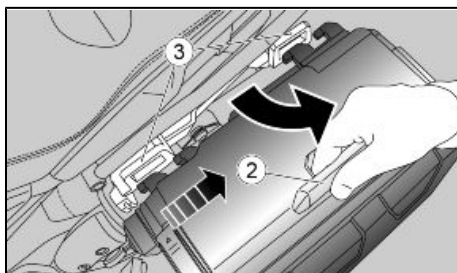

03\_34

- Holding the handle (2) pull the case backward to release it from the supports (3) and then remove it by moving it towards the outside.

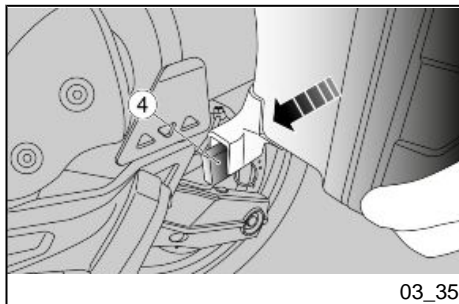

03\_35

#### NOTE

TO REPOSITION THE CASES, MAKE SURE THAT THE LOWER PART IS ATTACHED TO THE SUPPORT (4).



# V85 TT - V85 TT Travel E5



**Chap. 04**  
**Maintenance**

## Foreword

In general terms, scheduled maintenance can be carried out by the owner; however, some operations may require specific tools and technical training. For periodic maintenance, servicing or technical advice, contact an **Official Moto Guzzi Dealer** for prompt and accurate service.

### WARNING

**THIS VEHICLE HAS BEEN PROGRAMMED TO INDICATE IN REAL TIME ANY ACTIVATION FAILURE STORED IN THE ELECTRONIC CONTROL UNIT MEMORY.**

**ANY TIME THE IGNITION SWITCH IS SET TO "ON", THE "GENERAL ALARM" WARNING LIGHT ON THE INSTRUMENT PANEL TURNS ON FOR THREE SECONDS. IF THE WARNING LIGHT TURNS OFF, IT MEANS THAT THERE ARE NO MALFUNCTIONS.**

### NOTE

**HALVE THE SERVICE INTERVALS INDICATED IF THE VEHICLE IS USED IN PARTICULARLY RAINY OR DUSTY CONDITIONS, ON POOR ROADS OR FOR HIGH PERFORMANCE RIDING.**

## Engine oil level check (04\_01)

Check the engine oil level frequently.

### NOTE

**HALVE THE SERVICE INTERVALS INDICATED IF THE VEHICLE IS USED IN PARTICULARLY RAINY OR DUSTY CONDITIONS, ON POOR ROADS OR FOR HIGH PERFORMANCE RIDING.**



THE OIL LEVEL MUST BE CHECKED WHEN THE ENGINE IS WARM.

#### CAUTION

DO NOT LET THE ENGINE IDLE WITH THE VEHICLE AT A STANDSTILL TO WARM UP THE ENGINE AND OBTAIN THE OPERATING TEMPERATURE OF ENGINE OIL.

PREFERABLY CHECK THE OIL AFTER A JOURNEY OF AFTER TRAVELLING APPROXIMATELY 15 Km (10 miles) IN EXTRA-URBAN CONDITIONS (ENOUGH TO WARM UP THE ENGINE OIL TO OPERATING TEMPERATURE).

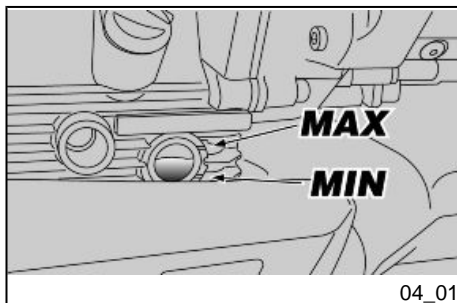

- Shut off the engine.
- Keep the vehicle upright with both wheels on the earth.
- Using the relative opening on the engine casing, check the oil level.

**MAX** (top notch) = maximum level.

**MIN** (bottom notch) = minimum level

- The level is correct if it reaches the "**MAX**" level.

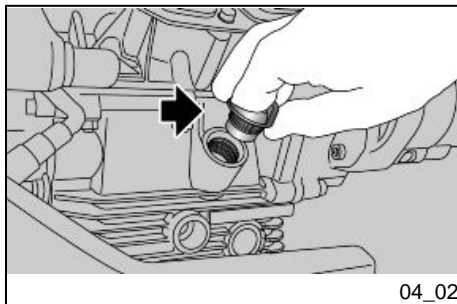

04\_02

## Engine oil top-up (04\_02)

If the engine oil needs to be topped up, proceed as follows:

- Unscrew and remove the cap.

### CAUTION

**ONLY USE THE ENGINE OIL TYPE INDICATED IN THE RECOMMENDED FLUIDS AND LUBRICANTS TABLE.**

- Pour in the necessary quantity of engine oil to reach the correct level.

### CAUTION

**DO NOT ADD ADDITIVES OR ANY OTHER SUBSTANCES TO THE OIL. WHEN USING A FUNNEL OR ANY OTHER ELEMENT, MAKE SURE IT IS PERFECTLY CLEAN.**

## Engine oil change

### CAUTION

**THE ENGINE OIL MUST BE CHECKED AND CHANGED BY AN Official Moto Guzzi Dealership**

## Engine oil filter replacement

### CAUTION

**THE ENGINE OIL FILTER MUST BE CHECKED AND CHANGED BY AN Official Moto Guzzi Dealership**



## Bevel gear pair oil level

### CAUTION

TO TOP-UP OR CHANGE THE OIL IN THE CARDAN SHAFT TRANSMISSION UNIT, CONTACT AN Authorised Moto Guzzi Dealer.

## Gearbox oil level

### CAUTION

THE GEARBOX OIL MUST BE CHECKED AND CHANGED BY AN Official Moto Guzzi Dealership.

## Tyres (04\_03)

This vehicle is fitted with tubeless tyres (without inner tubes).

### CAUTION

CHECK TYRE INFLATION PRESSURE REGULARLY AT AMBIENT TEMPERATURE. THE MEASUREMENT MAY BE INCORRECT IF TYRES ARE WARM. CHECK TYRE PRESSURE MAINLY BEFORE AND AFTER A LONG TRIP. AN OVER-INFLATED TYRE WILL PROVIDE A HARSH RIDE AS SURFACE UNEVENNESS IS NOT CUSHIONED AND IS SENT TO THE HANDLEBAR, THUS REDUCING GRIP AND ROAD HOLDING SPECIALLY WHEN CORNERING.

ON THE OTHER HAND, AN UNDER-INFLATED TYRE CAUSES THE CONTACT PATCH TO INCLUDE A LARGER PORTION OF THE TYRE SIDE WALLS. IF SO, THE TYRE MIGHT SLIP ON OR GET DETACHED FROM THE WHEEL RIM, RESULTING IN LOSS OF CONTROL OVER THE VEHICLE.

EVENTUALLY THE VEHICLE MIGHT SKID IN A BEND.

**CHECK THE SURFACE CONDITION AND WEAR BECAUSE POOR TYRE CONDITION COULD COMPROMISE GRIP AND HANDLING OF THE VEHICLE.**

**SOME TYRE TYPES APPROVED FOR THIS VEHICLE FEATURE WEAR INDICATORS.**

**THERE ARE SEVERAL TYPES OF WEAR INDICATORS. CONSULT YOUR DEALER ON METHODS TO CHECK FOR WEAR.**

**CARRY OUT A VISUAL INSPECTION FOR TYRE WEAR AND TEAR, REPLACE TYRES WHEN WORN.**

**WHEN TYRES ARE OLD, THE MATERIAL MAY HARDEN AND NOT PROVIDE ADEQUATE ROAD HOLDING, EVEN IF TYRES ARE STILL WITHIN THE WEAR LIMIT. REPLACE TYRES IF THIS OCCURS. REPLACE THE TYRE IF IT IS WORN OR IF THERE IS A PUNCTURE LARGER THAN 5 mm (0.197 in) IN THE TREAD AREA.**

**WHEEL MUST BE BALANCED AFTER A TYRE IS MENDED.**

**USE ONLY TYRE SIZES INDICATED BY THE MANUFACTURER. DO NOT FIT TYRES WITH INNER TUBES ON RIMS FOR TUBELESS TYRES OR VICE VERSA. CHECK THAT THE INFLATION VALVES HAVE THEIR CAPS FITTED TO AVOID UNEXPECTED FLAT TYRES.**

**REPLACEMENT, REPAIR, MAINTENANCE AND BALANCING OPERATIONS ARE HIGHLY IMPORTANT AND SO THEY SHOULD BE CARRIED OUT USING THE SPECIFIC TOOLS AND WITH THE ADEQUATE KNOWLEDGE. HAVE YOUR TYRES AND WHEELS SERVICED AT AN AUTHORISED DEALER OR A SPECIALISED TYRE WORKSHOP.**

**NEW TYRES MAY BE COATED WITH AN OILY FILM: RIDE WITH CAUTION DURING THE FIRST KILOMETRES. DO NOT APPLY UNSUITABLE LIQUIDS ON TYRES.**

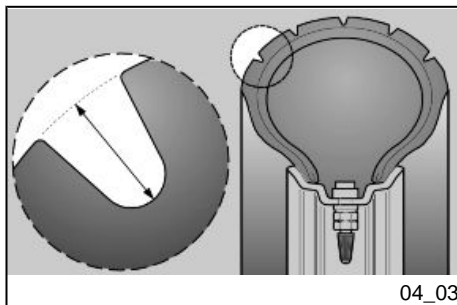
**Minimum tread depth:**

front and rear 2 mm (0.079 in) (USA 3 mm) (USA 0.118 in) and anyway not lower to what it is specified in the current legislation in the country in which the vehicle is used.

**Spark plug dismantlement****CAUTION**

**FOR REMOVAL, CHECK, AND REPLACEMENT OF THE SPARK PLUGS CONTACT AN OFFICIAL Moto Guzzi Dealer.**

**Removing the air filter****CAUTION**

**TO REMOVE, CHECK AND REPLACE THE AIR FILTER, CONTACT AN Official Moto Guzzi Dealer.**

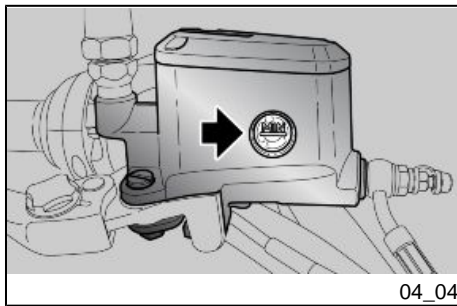

04\_04

## Checking the brake oil level (04\_04, 04\_05)

### Front brake fluid check

- Rest the vehicle on its stand.
- Turn the handlebar so that the fluid is at the same level as the plug
- Make sure that the fluid level in the reservoir is above the "MIN" reference mark

**MIN** = minimum level

If the fluid does not reach at least the "MIN" reference mark:

### CAUTION

**FLUID LEVEL DECREASES GRADUALLY AS BRAKE PADS WEAR DOWN.**

- Check brake pads and discs for wear.

If the brake pads and/or brake discs do not have to be replaced, have the braking system checked at an **Official Moto Guzzi Dealership**.

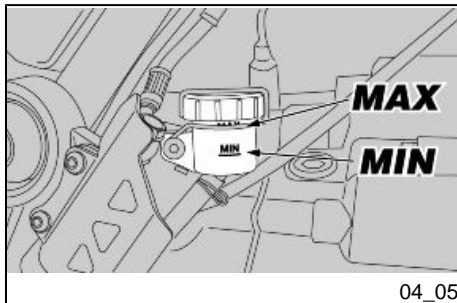

04\_05

### Rear brake fluid check

- Keep the vehicle upright so that the fluid in the reservoir is at the same level as the plug.
- Make sure that the fluid level in the reservoir is above the "MIN" reference mark:

**MIN** = minimum level

**MAX** = maximum level

If the fluid does not reach at least the "MIN" reference mark:

### CAUTION

**FLUID LEVEL DECREASES GRADUALLY AS BRAKE PADS WEAR DOWN.**

- Check brake pads and discs for wear.

If the brake pads and/or brake discs do not have to be replaced, have the braking system checked at an **Official Moto Guzzi Dealership**.

## Braking system fluid top up

### CAUTION

**FOR THE TOP-UP OF THE BRAKING SYSTEMS COOLANT, CONTACT AN Official Moto Guzzi Dealer.**

## Battery removal (04\_06, 04\_07, 04\_08, 04\_09)

- Ensure that the ignition switch is turned to "KEY OFF";
- Remove the saddle;
- Remove the glove box fixing screws (1);

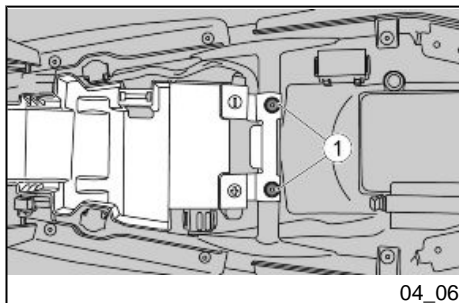

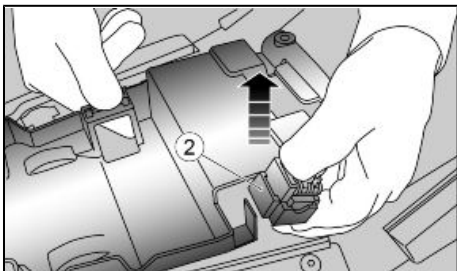

04\_07

- Detach the main fuse support (2) from the glove box;

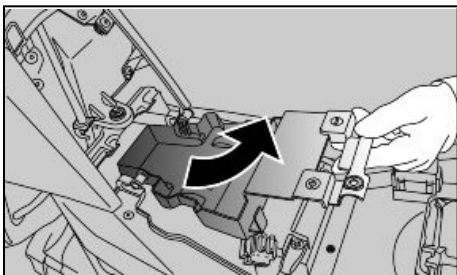

04\_08

- Detach the glove box at the front and remove it.

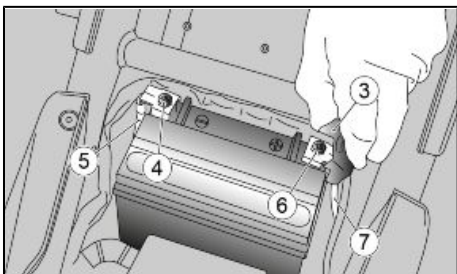

04\_09

- Unscrew and remove the screw (4) of the negative terminal (-).
- Move the negative lead (5) aside.
- Remove the protective cap (3) and unscrew and remove the screw (6) from the positive terminal (+).
- Move the positive lead (7) aside.
- Remove the battery retainer bracket (7).
- Grip the battery firmly and remove from its seat.
- Put the battery away on a level surface, in a cool and dry place.



**CHECK THAT THE CABLE TERMINALS AND BATTERY LEADS ARE:**

- **IN GOOD CONDITION (NOT CORRODED OR COVERED BY DEPOSITS);**
- **COVERED BY NEUTRAL GREASE OR PETROLEUM JELLY.**



**REMOVING THE BATTERY RESETS THE DIGITAL CLOCK AND THE TRIP JOURNAL FUNCTIONS.**

**CAUTION**



**ONCE REMOVED, THE BATTERY MUST BE PUT AWAY IN A SAFE PLACE OUT OF THE REACH OF CHILDREN.**

**CAUTION**

**UPON REFITTING, CONNECT THE LEAD TO THE POSITIVE TERMINAL (+) FIRST AND AFTERWARDS THE LEAD TO THE NEGATIVE TERMINAL (-).**

## **Checking the electrolyte level**

**WARNING**

**THIS VEHICLE IS FITTED WITH A MAINTENANCE-FREE BATTERY AND DOES NOT NEED ANY INTERVENTION, EXCEPT FOR SPORADIC CHECKS AND RECHARGE.**

## Charging the battery

- Remove the battery.
- Get an adequate battery charger.
- Set the battery charger for the recharge type indicated.
- Connect the battery to the battery charger.

### CAUTION



**WHEN RECHARGING OR USING THE BATTERY, BE CAREFUL TO HAVE THE ROOM ADEQUATELY AIRED. DO NOT BREATH GASES RELEASED WHEN THE BATTERY IS RECHARGING.**

- Switch on the battery charger.

### CHARGE MODES

#### Ordinary recharge

- Electric current: 1.4 A
- Time required: 5 -10 hours

#### Quick recharge

- Electric current: 6 A
- Time required: 1 hours

## Long periods of inactivity

If the vehicle is inactive longer than fifteen days, it is necessary to recharge the battery to avoid sulphation.

- Remove the battery and put it away in a cool and dry place.



In winter or when the vehicle is out of use for prolonged periods, check charge level frequently (about once a month) to prevent deterioration.

- Recharge it fully with an ordinary charge.

If the battery is still on the vehicle, disconnect the cables from the terminals.

#### **Checking and cleaning terminals and leads**

- Partially remove the battery from its housing.
- Check that the battery cable terminals and leads are in good conditions (not corroded or covered by deposits) and covered with neutral grease or petroleum jelly.

### **Fuses (04\_10, 04\_11, 04\_12, 04\_13)**

#### **CAUTION**



**DO NOT ATTEMPT TO REPAIR FAULTY FUSES.**

**NEVER USE A FUSE THAT IS DIFFERENT THAN WHAT IS SPECIFIED TO PREVENT DAMAGES TO THE ELECTRICAL SYSTEM OR SHORT CIRCUITS, AND THE RISK OF FIRE.**

#### **NOTE**

**A FUSE THAT BLOWS FREQUENTLY MAY INDICATE A SHORT CIRCUIT OR OVERLOAD. IF THIS OCCURS, CONTACT AN Official Guzzi Dealer.**

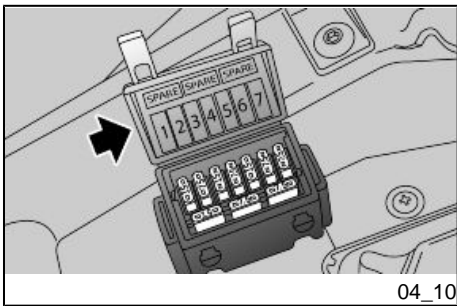

04\_10

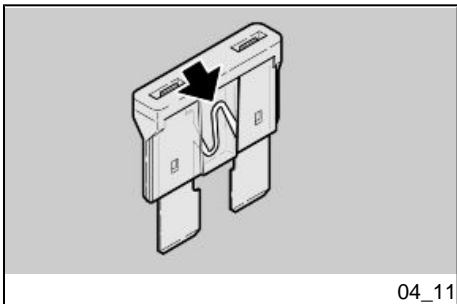

04\_11

**To check:**

- Set the ignition switch to 'OFF' to avoid an accidental short circuit.
- Remove the saddle.
- Remove the fuse box cover.
- Take out one fuse at a time and check if the filament is broken.
- Before replacing the fuse, find and solve, if possible, the reason that caused the problem.
- If the fuse is damaged, replace it with one of the same current rating.

**NOTE**

**IF THE SPARE FUSE IS USED, REPLACE WITH ONE OF THE SAME TYPE IN THE CORRESPONDING FITTING.**

**MAIN FUSES**

A) 30A fuse	Battery charging, all vehicle utilities.
B) 20A fuse	ABS power feed
L) spare fuses	

They are located under the saddle on the left side

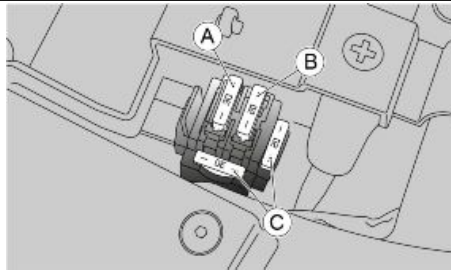

04\_12

## **SECONDARY FUSES**

C) 15A fuse	Low beam/high beam lights and passing, brake lights, DRL/position lights, horn, fog lights (where required), lights control
D) 7.5A fuse	Instrument cluster power supply, antitheft device power supply, hand grips and turn indicators
E) 15A fuse	ECU positive switched live, instrument cluster positive switched live, ABS positive switched live, starter relay, CAN left light switch

F) 7.5A fuse	ECU permanent positive lead
G) 7.5A fuse	Bluedash (GMP), OBD
H) 7.5A fuse	USB socket, anti theft device
I) 15A fuse	ECU power, secondary air system, injectors, starter coils, fuel pump, canister

L) spare fuses

*They are located under the saddle on the right side*

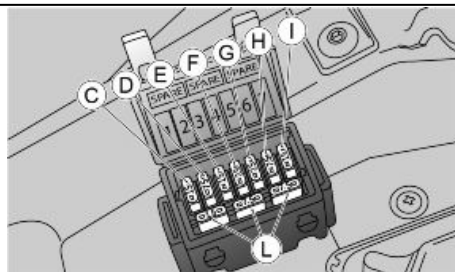

04\_13

## Front light group

### NOTE

**WHEN THE REAR WHEEL EXCEEDS THE SPEED OF 1 km/h (0.62 mph) (EVEN WITH THE ENGINE OFF, AND THE KEY SET TO ON), THE HEADLIGHTS WILL**

**TURN ON AND WILL REMAIN ON FOR 30 SECONDS (FROM THE TIME IN WHICH THE REAR WHEEL STOPS MOVING).**

#### CAUTION

**TO REMOVE, CHECK AND REPLACE THE FRONT LIGHT ASSEMBLY LAMPS, CONTACT AN Authorised Moto Guzzi Dealership**

### Headlight adjustment (04\_14, 04\_15, 04\_16)

#### NOTE

**IN COMPLIANCE WITH LOCAL LEGAL REQUIREMENTS, SPECIFIC PROCEDURES MUST BE FOLLOWED WHEN CHECKING LIGHT BEAM ADJUSTMENT.**

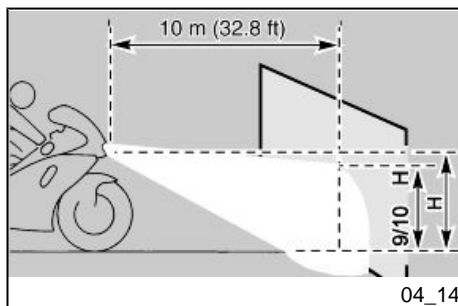

#### For a quick check of the correct direction of the front light beam:

- Place the vehicle 10 m (32.81 ft) away from a vertical wall and make sure the ground is level.
- Turn on the low beam light, sit on the vehicle and check that the light beam projected to the wall is a little below the headlight horizontal straight line (about 9/10 of the total height).

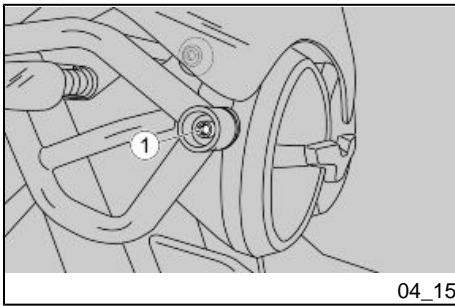

04\_15

#### To carry out vertical adjustment of the light beam:

- Stand the motorcycle in a vertical position.
- Slightly loosen the headlight fixing screws (1) on both sides.

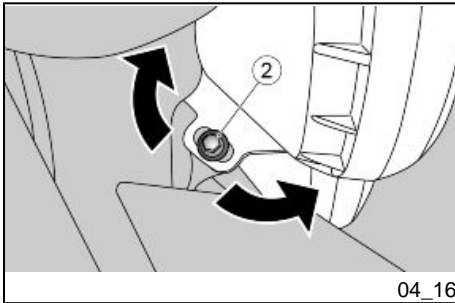

04\_16

- Slightly loosen the headlight fixing screw (2), and move the light beam manually to the desired position.
- Once adjusted, tighten all the screws.

After adjusting:

#### NOTE

**CHECK THAT THE VERTICAL ALIGNMENT OF THE BEAM IS CORRECT.**

#### Front direction indicators

#### NOTE

**TO REMOVE, CHECK AND REPLACE THE FRONT TURN INDICATORS, PLEASE CONTACT AN Authorised Moto Guzzi Dealership**

## Additional light (04\_17, 04\_18)

### ADJUSTMENT

- By positioning the vehicle in travel set-up with the fog lights at a distance of 1 m (39 in) from a vertical wall, the upper edge of the projected beam of light must be at least 5 mm (0.2 in) lower than the height of the lens centers of the fog lights from the ground.

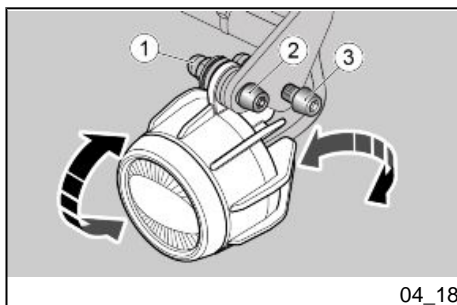
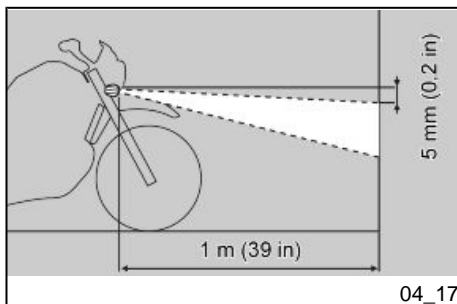

- For vertical adjustment, it is necessary to loosen the nut (1) of the screw (2), proceed with the orientation of the fog lights and then tighten the nut to fix the position.
- For horizontal adjustment, act on the screw (3) turning it clockwise to align the light beam towards the road centre and anticlockwise to obtain an inverse alignment.

### Bulb replacement

#### CAUTION

**FOR THE REMOVAL, CHECK AND REPLACEMENT OF THE ADDITIONAL LIGHTS CONTACT AN OFFICIAL Moto Guzzi Dealer.**

## Rear optical unit

### CAUTION

TO REMOVE, CHECK AND REPLACE THE REAR LIGHT ASSEMBLY, CONTACT AN Authorised Moto Guzzi Dealership.

## Rear turn indicators

### NOTE

FOR DISASSEMBLY, VERIFICATION AND REPLACEMENT OF REAR INDICATORS PLEASE CONTACT AN Official Moto Guzzi Dealership

## Rear-view mirrors (04\_19, 04\_20)



DO NOT RIDE WITH REAR-VIEW MIRRORS INCORRECTLY SET.

ALWAYS CHECK THAT THE MIRRORS ARE ADJUSTED CORRECTLY BEFORE SETTING OFF.



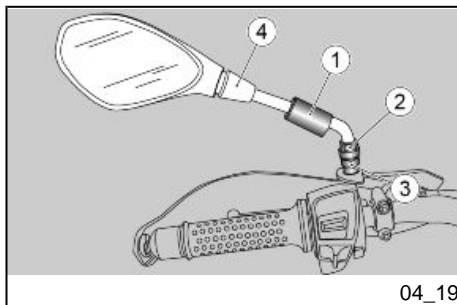

#### Rear-view mirrors removal:

- Rest the vehicle on its stand.
- Lift the rubber protection (1).
- Loosen the locking nut (2) while holding the threaded clamp (3).
- Slide up and remove the complete rear-view mirror unit (4).

Repeat the procedure to remove the other rear-view mirror, if necessary.



**UPON REFITTING AND BEFORE TIGHTENING THE LOCKING NUT, MAKE SURE THAT THE REAR VIEW MIRROR SUPPORT STEM IS ALIGNED WITH THE HANDLEBAR.**

#### CAUTION

**THE VEHICLE MAY NOT BE RIDDEN ON PUBLIC ROADS WITH THE REAR VIEW MIRRORS REMOVED.**

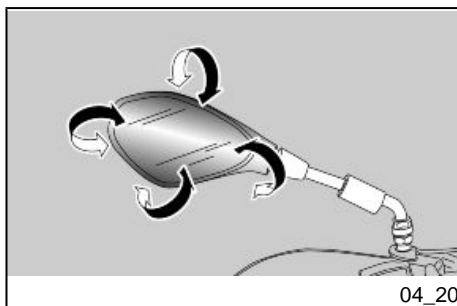

#### Rear-view mirrors adjustment:

- Get onto the bike in the riding position.
- Turn the mirror, correctly adjusting the inclination.

Repeat the procedure to adjust the other mirror.

- Make sure there is no dirt or mud.

## Front and rear disc brake (04\_21, 04\_22, 04\_23)

### CAUTION



A DIRTY DISC SMEARS THE PADS RESULTING IN POOR BRAKING.

REPLACE DIRTY PADS AND CLEAN AGAIN THE DIRTY DISC USING A TOP QUALITY DEGREASING PRODUCT.

### CAUTION

TAKE YOUR VEHICLE TO AN Authorised Moto Guzzi Dealer TO HAVE THE FRONT WHEEL REMOVED.

### CAUTION



CHECK BRAKE PADS FOR WEAR MAINLY BEFORE EACH RIDE.

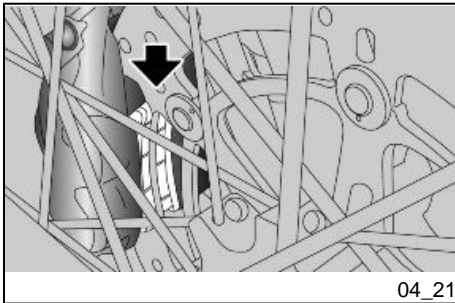

### To perform a quick pad wear check:

Place the vehicle on the stand and visually inspect the brake disc and pads as follows:

- **For the front brake callipers:** standing on the LH side of the vehicle, check the RH brake calliper (through the rim) and vice versa for the LH brake calliper.
- **For the rear brake calliper:** stand behind.

### CAUTION

EXCESSIVE WEAR OF THE FRICTION MATERIAL MAKES THE PAD METAL SUPPORT GET INTO CONTACT WITH THE DISC, WHICH RESULTS IN A METALLIC NOISE AND SPARKS IN THE CALLIPER; THEREFORE, BRAKING EFFICIENCY AND DISC SAFETY AND INTEGRITY ARE AT RISK.

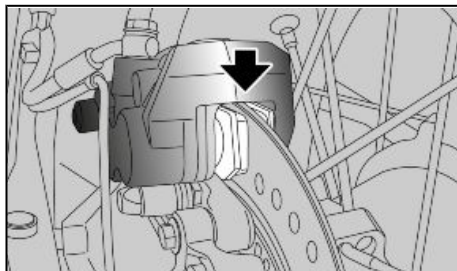

04\_22

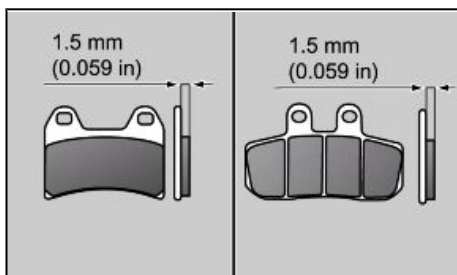

04\_23

If the friction material thickness (even of one front or rear pad) is reduced to a value of about **1.5 mm (0.059 in)** (or even if one of the wear indicators is not very visible), contact an **Authorised Moto Guzzi Dealer** to replace all the brake callipers.

### Periods of inactivity (04\_24)

Take some measures to avoid the side effects of not using the scooter. Besides, it is necessary to carry out general repairs and checks before garaging the motorcycle as one can forget to do so afterwards.

Proceed as follows:

- Remove the battery.
- Wash and dry the motorcycle.
- Apply wax polish to painted and chromed surfaces.
- Inflate the tyres.

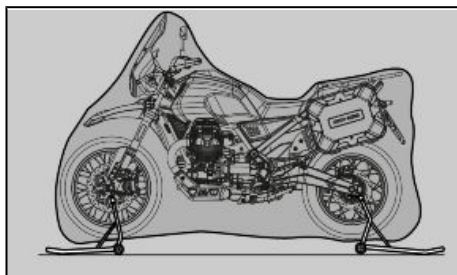

04\_24

- Set the vehicle in a room with no heating or humidity, with minimum temperature variations and not exposed to sun rays.
- Wrap and tie a plastic bag around the exhaust pipe opening to keep moisture out.

**CAUTION**

**PLACE THE VEHICLE ON SUITABLE SUPPORTS TO KEEP THE TYRES OFF THE GROUND.**

Cover the vehicle but do not use plastic or waterproof materials.

**CAUTION**

**TO AVOID BATTERY DETERIORATION, FOLLOW THE PROCEDURE DESCRIBED FOR PROLONGED INACTIVITY.**

**AFTER STORAGE****NOTE**

**TAKE THE PLASTIC BAGS OFF THE EXHAUST PIPE OPENING.**

- Uncover and clean the vehicle.
- Check the battery for correct charge and install it.
- Refill the fuel tank.
- Carry out the pre-ride checks.

**CAUTION**

**AS A TEST, RIDE THE MOTORCYCLE FOR A FEW KILOMETRES AT A MODERATE SPEED AND AWAY FROM TRAFFIC AREAS.**

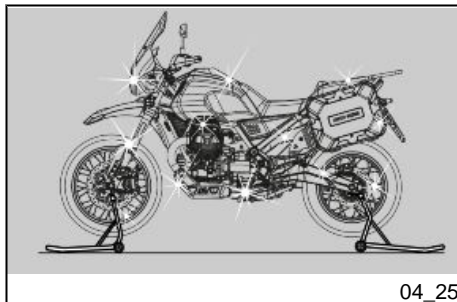

04\_25

## Cleaning the vehicle (04\_25, 04\_26, 04\_27)

Moto Guzzi recommends using quality products for cleaning the vehicle. The use of unsuitable products can damage vehicle components. For cleaning do not use solvents such as "nitro thinner", "cold cleaning agents", or similar fuels, or cleaning products that contain alcohol.

### WASHING THE MOTORCYCLE

Moto Guzzi recommends softening with water and then carefully removing the insects and stubborn stains before washing the vehicle.

To prevent stains, do not wash the motorcycle immediately after exposure to sunlight, and do not wash it in the sun.

If the vehicle is used during the winter months, be sure to frequently wash the motorcycle. To remove anti-icing salt sprayed on roads in the winter, wash the motorcycle with cold water immediately after use.



**USE OF HOT WATER INTENSIFIES THE EFFECT OF THE SALT. USE ONLY PLENTY OF COLD WATER TO WASH AND REMOVE ANTI-ICING SALT**



**USE OF HIGH PRESSURE WASHING SYSTEMS (OR STEAM CLEANERS) CAN DAMAGE THE SEALS, OIL SEALS, BRAKING SYSTEM, ELECTRICAL SYSTEM AND THE SADDLE. DO NOT USE STEAM OR HIGH PRESSURE CLEANING SYSTEMS. DO NOT INSIST WITH THE PRESSURE NOZZLE ON THE WHEEL BEARINGS, INSIDE THE REAR WHEEL HUB, ON THE HYDRAULIC BRAKING CIRCUIT AND ON THE ELECTRICAL PARTS.**

### CLEANING OF SENSITIVE PARTS

## BODYWORK

To keep the motorcycle bright, wash it regularly, especially if used in areas with high levels of pollution or mud. Aggressive stains from tree resins, gasoline, oil, brake fluid or bird excrement in general.

must be removed immediately, otherwise permanent stains on the paint can appear. After washing is easy to identify marks and residual stains, remove these from the bodywork using a soft cloth, of a non-abrasive polish brand. Periodic care, a thorough cleaning of the bodywork preserves the aesthetic quality of the motorcycle over the long term.

## PLASTIC COMPONENTS



**IF THE PLASTIC COMPONENTS ARE CLEANED USING AGGRESSIVE AGENTS, THE SURFACE MAY BE DAMAGED. DO NOT USE CLEANING PRODUCTS CONTAINING ALCOHOL, SOLVENTS OR THAT ARE ABRASIVE FOR THE CLEANING OF PLASTIC PARTS. ROTARY BRUSHES OR SPONGES WITH HARD SURFACES CAN MAKE SCRATCHES**

## FRONT HEADLIGHT

Do not use products containing aggressive agents during use or during washing, due to the structure of the bottom bracket cup, under the frame can be detected water or dirt.

Since water outside the headlight will dry due to the heat and ventilation during use of the motorcycle, in case of persistence use compressed air at a distance of 10 cm from the headlight.



**TO CLEAN THE HEADLIGHTS USE A SPONGE SOAKED IN WATER AND MILD DETERGENT, RUBBING THE SURFACE GENTLY AND RINSING FREQUENTLY WITH PLENTY OF WATER. DO NOT POLISH MATT-PAINTED SURFACES WITH**

**POLISHING PASTE. THE VEHICLE SHOULD NEVER BE WASHED IN DIRECT SUNLIGHT, ESPECIALLY DURING SUMMER, OR WITH THE BODYWORK STILL HOT AS THE CAR SHAMPOO CAN DAMAGE THE PAINTWORK IF IT DRIES BEFORE BEING RINSED OFF.**

**CAUTION****WARNING**

**AFTER HEAVY RAIN, WASHING OR IN CASE OF RAPID TEMPERATURE CHANGES, THE LENSES OF THE FRONT LIGHT ASSEMBLY MAY BECOME FOGGY.**

**THIS STATE IS DUE TO THE TEMPERATURE DIFFERENCE BETWEEN THE OUTSIDE AND THE INSIDE AND DOES NOT INDICATE A FAULT OF THE FRONT LIGHT ASSEMBLY.**

**CHROME PARTS AND POLISHED METAL**

**TREAT THE PARTS MADE OF CHROME, ALUMINIUM OR POLISHED STEEL IN A SPECIAL MANNER. WASH THEM WITH PLENTY OF WATER AND CAR SHAMPOO, POLISH AND REGULARLY BRIGHTEN THEM WITH DEDICATED PASTE, PROTECT THEM WITH SUITABLE ACID-FREE PRODUCTS (E.G. VASELINE)**

**RUBBER PARTS**

Clean the rubber parts using water and mild shampoo (brand-name, suitable for car bodies)

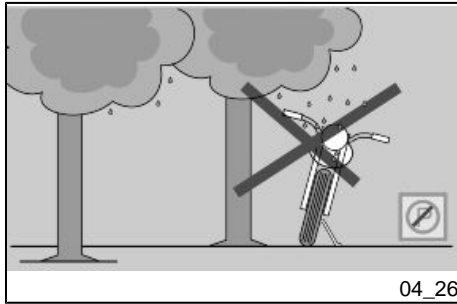

**THE USE OF SILICONE SPRAY TO CLEAN THE RUBBER SEALS MAY CAUSE DAMAGE. DO NOT USE OTHER PRODUCTS CONTAINING SILICON FOR CLEANING THE MOTORCYCLE**

**Clean the motorcycle frequently if exposed to adverse conditions, such as:**

- Air pollution (cities and industrial areas).
- Salinity and humidity in the atmosphere (seashore areas, hot and wet weather).
- Special environmental/seasonal conditions (use of salt, anti-icing chemical products on the roads in winter).
- Always clean off any smog and pollution residue, tar stains, insects, bird droppings, etc. from the bodywork.
- Avoid parking the vehicle under trees. During some seasons, resins, fruits or leaves containing aggressive chemical substances that may damage the paintwork may fall from trees.

#### CAUTION



**BEFORE WASHING THE VEHICLE, COVER THE ENGINE AIR INTAKES AND THE EXHAUST PIPES.**

#### CAUTION



**CLEAN THE INSTRUMENT PANEL WITH A SOFT CLOTH MOISTENED WITH WATER.**



**CAUTION**

**AFTER CLEANING YOUR MOTORCYCLE, BRAKING EFFICIENCY MAY BE TEMPORARILY AFFECTED DUE TO THE PRESENCE OF WATER ON THE FRICTION SURFACES OF THE BRAKING CIRCUIT. ALLOW LONGER BRAKING DISTANCES TO PREVENT ACCIDENTS. BRAKE REPEATEDLY TO RESTORE NORMAL OPERATION. CARRY OUT THE PRE-RIDE CHECKS.**

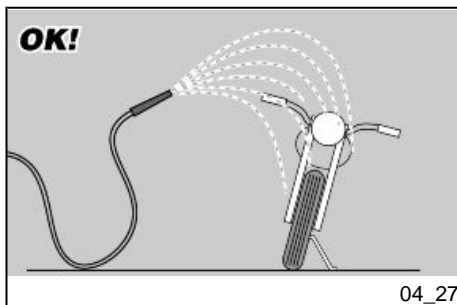

To remove dirt and mud accumulated on painted surfaces, wet the soiled areas thoroughly with a low-pressure water jet, then remove dirt and mud with a soft car body sponge soaked abundantly in a solution of car body shampoo in water (2 - 4% shampoo dissolved in water). Then rinse with plenty of water, and dry with a chamois leather. To clean the engine outer parts, use degreasing detergent, brushes and old cloths. Wash anodised or painted aluminium parts with neutral soap and water. Using aggressive detergents may damage the surface treatment of these components.

**CAUTION**

**NEVER USE CLOTHS SOAKED IN PETROL, DIESEL OIL OR KEROSENE FOR CLEANING THE PAINTED OR PLASTIC SURFACES SO AS NOT TO DAMAGE THE LUSTRE FINISH OR ALTER THE MECHANICAL PROPERTIES.**

**CAUTION**

**DO NOT USE WATER (OR LIQUIDS) AT TEMPERATURES OVER 40°C (104°F) WHEN CLEANING THE VEHICLE PLASTIC PARTS. DO NOT AIM HIGH PRESSURE AIR/WATER JETS OR STEAM JETS DIRECTLY ON THESE COMPONENTS. DO NOT USE ALCOHOL OR SOLVENTS TO CLEAN ANY RUBBER OR PLASTIC SADDLE COMPONENTS USE WATER AND MILD SOAP.**

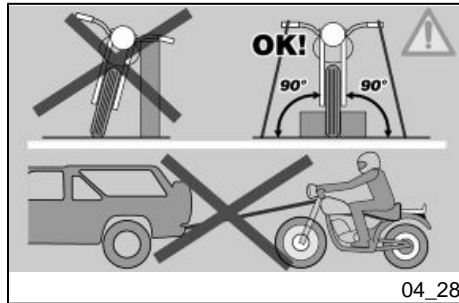
**CAUTION**

**DO NOT USE SOLVENTS OR PETROL BY-PRODUCTS (ACETONE, TRICHLOROETHYLENE, TURPENTINE, PETROL, THINNERS) TO CLEAN THE SADDLE. USE INSTEAD DETERGENTS WITH SURFACE ACTIVE AGENTS NOT EXCEEDING 5% (NEUTRAL SOAP, OR NEUTRAL DETERGENTS).**

**DRY THE SADDLE WELL AFTER CLEANING.**

**THE USE OF WAX OR SIMILAR PRODUCTS COMPROMISES THE SAFETY OF THE SADDLE ITSELF.**



**WHEN USING A SYSTEM OF PRESSURE WASHING (AFTER CHECKING THAT ANY DETERGENTS ARE COMPATIBLE WITH THE MOTORCYCLE FINISH), KEEP A DISTANCE OF AT LEAST ONE METRE.**



**CLEAN THE VEHICLE IMMEDIATELY WITH COLD WATER AFTER RIDING ON A ROAD TREATED WITH SALT: SALT IS HIGHLY CORROSIVE.**

**Transport (04\_28)****NOTE**

**BEFORE TRANSPORTING THE VEHICLE, CAREFULLY EMPTY THE FUEL TANK AND CHECK THAT IT IS COMPLETELY DRY.**

**WHILE IT IS BEING MOVED, THE VEHICLE MUST REMAIN IN THE VERTICAL POSITION AND BE FIXED SECURELY IN POSITION IN ORDER TO AVOID SPILLING FUEL OR OIL.**

**IN CASE OF FAILURE, DO NOT TOW THE VEHICLE BUT CONTACT A ROAD ASSISTANCE SERVICE INSTEAD TO HAVE THE INFLAMMABLE FLUIDS DRAINED .**



# V85 TT - V85 TT Travel E5



**Chap. 05**  
**Technical data**

## **DIMENSIONS AND MASS**

Maximum Length	2,240 mm (88.19 in)
Maximum width	950 mm (37.40 in)
Height (with adjustable windshield) (V85 TT)	1300 - 1325 mm (51.18 - 52.17 in)
Height (with adjustable windshield) (V85 TT Travel)	1420 - 1445 mm (55.90 - 56.89 in)
Wheelbase	1530 mm (60.24 in)
Kerb weight (V85 TT)	229 kg (504.86 in)
Kerb weight (V85 TT Travel)	242 kg (533.52 in)

## **ENGINE**

Type	traverse-mounted four-stroke V 90°	twin-cylinder
Number of cylinders	2	
Engine capacity	853 cc (52.05 cu in)	
Bore / stroke	84x77 mm (3.31x3.03 in)	
Compression ratio	10.5 ± 0.5: 1	

Starting	Electric
Idle engine speed	1,250 +/- 100 (rpm)
Clutch	single disc dry clutch with flexible coupling
Lubrication system	pressure-fed, controlled by valves and trochoidal pump
Air filter	cartridge-type dry filter
Cooling	air

### **GEARBOX**

Type	mechanical, 6 speeds with foot lever on the left hand side of the engine
------	--

### **CAPACITY**

Fuel tank capacity (including reserve)	23 +/- 1 l (5.06 +/- 0.22 UK gal; 6.08 +/- 0.26 US gal)
Fuel tank reserve capacity	5 +/- 0.5 l (1.10 +/- 0.11 UK gal; 1.32 +/- 0.13 US gal)

Engine oil	Oil change and oil filter replacement: 1760 cm <sup>3</sup> (107.40 cu.in)
Gearbox oil	700 cc (42.72 cu in)
Bevel gear set oil	180 cm <sup>3</sup> (10.98 cu.in)
Bevel gear oil (in case of replacement)	160 cc (9.76 cu in) MAX
Seats	2
Maximum carrying load (V85 TT)	448 kg (987.67 lb) (rider + passenger + luggage)
Maximum carrying load (V85 TT Travel)	461 kg (1016.33 lb) (rider + passenger + luggage)

### **TRANSMISSION**

Primary drive	with gears, ratio: 18/23 = 1 : 1,277
Gear ratios, 1st gear	16 / 39 = 1: 2,437
Gear ratios, 2nd gear	18 / 32 = 1: 1,777
Gear ratios, 3rd gear	21 / 28 = 1: 1,333
Gear ratios, 4th gear	24 / 26 = 1: 1,083
Gear ratios, 5th gear	25 / 24 = 1: 0,96
Gear ratios, 6th gear	27 / 24 = 1 : 0,888



Final drive	with shaft, ratio $8 / 33 = 1 : 4,125$
-------------	--

### **POWER SUPPLY**

Type	Electronic injection (Marelli 11MP)
Diffuser	Ø 52 mm (2.05 in)
Fuel	Unleaded gasoline E10 (95 R.O.N.)

### **CHASSIS**

Type	high strength tubular steel frame
Steering rake angle	25,7°
Trail	128.3 mm (5.05 in)

### **SUSPENSIONS**

Front	hydraulic telescopic fork, Ø 41 mm (1.61 in)
Travel	168 mm (6.61 in)
Rear	Swingarm in die-cast light alloy with 1 shock absorber with

	adjustable spring pre-loading and hydraulic brake extension.
--	--

Travel	102 mm (4.02 in)
--------	------------------

### **BRAKES**

Front	Ø 320-mm (12.59 in) stainless steel floating disc, calliper with 4 Ø 32 mm (1.26 in) counteracting plungers
-------	---

Rear	260 mm (10.24 in) stainless steel disc, floating calliper with two 22 mm (0.87 in) diameter pistons
------	---

### **WHEEL RIMS**

Type	alloy, with spokes
------	--------------------

Front	2.5" x 19"
-------	------------

Rear	4.25" x 17"
------	-------------

### **TYRES**

Front	110 / 80 R19 59V
-------	------------------

Tyre pressure	2.5 bar (250 kPa) (36.26 PSI)
Rear	150 / 70 R17 69V
Tyre pressure	2.8 bar (280 Kpa) (40.61 PSI)
<b>CAUTION</b>	<b>When using anti-skid wheels it is recommended to decrease the inflation pressure by 0.2 bar (20 Kpa) (2.90 PSI) at the front and 0.3 bar (30 Kpa) (4.35 PSI) at the rear.</b>

### **SPARK PLUGS**

Standard	NGK IR MR8BI-8
Spark plug electrode gap	0.8 mm (0.031 in)
Resistance	7.5 KOhm (MAX)

### **ELECTRICAL SYSTEM**

Battery	12 V - 12 Ah
Fuses	30 - 20 - 15 (3) - 7.5 (4) A
Permanent magnet alternator	12V - 430W

## **BULBS**

High beam/low beam light	LED
Fog lights	LED
Front DRL	LED
Turn signal lights	LED
Rear running light / brake light	LED
Dashboard lighting	LED

## **INDICATOR LAMPS**

Gearbox in neutral	LED
High beam light	LED
Cruise control warning light	LED
ABS warning light	LED
MI warning light	LED
Turn indicators	LED
Overspeed threshold / gear shift warning lights	LED
Immobilizer warning light	LED
Fuel reserve	LED

MGCT warning light	LED
General alarm	LED
Daytime running lights warning light	LED
Side stand warning light	LED



# V85 TT - V85 TT Travel E5



**Chap. 06**  
**Programmed**  
**maintenance**



06\_01

## Scheduled maintenance table (06\_01, 06\_02)

Adequate maintenance is fundamental to ensure long-lasting, optimum operation and performance of your vehicle.

For this reason a series of checks and maintenance services has been prepared, available for purchase separately, listed together in the chart on the following page. It is a good idea to report small performance anomalies right away to an **Authorised Service Centre**, without waiting for the next scheduled service, so they can be repaired immediately.

It is necessary to have your vehicle serviced to the prescribed intervals of time, even if you have not reached the predicted mileage. Services must be performed punctually at the correct intervals to maintain the validity of the warranty. For any additional information concerning Warranty procedures and 'Scheduled Maintenance', please consult the 'Warranty Conditions'.

### NOTE

**HALVE THE SERVICE INTERVALS INDICATED IF THE VEHICLE IS USED IN PARTICULARLY RAINY OR DUSTY CONDITIONS, ON POOR ROADS OR FOR HIGH PERFORMANCE RIDING.**

I: CHECK AND CLEAN, ADJUST, LUBRICATE OR REPLACE, IF NECESSARY

C: CLEAN, R: REPLACE, A: ADJUST, L: LUBRICATE

(1): Replace in case of leaks

(2): Check every month

(3): Check every 500 km (310 miles)

(4): Check and clean, adjust or replace if necessary every 1000 km (621 miles)

(5): Replace at whichever of the following occurs first: 40,000 km (24,855 miles) or 4 years



**SCHEDULED MAINTENANCE TABLE**

<b>Km x 1,000 (mi x 1,000)</b>	<b>1,5 (0.9)</b>	<b>10 (6.2)</b>	<b>20 (12.4)</b>	<b>30 (18.6)</b>	<b>40 (24.9)</b>	<b>50 (31.1)</b>	<b>60 (37.3)</b>	<b>EVER Y 12 MONT HS</b>	<b>EVER Y 24 MONT HS</b>
Oil filter cover O-ring	R	R	R	R	R	R	R	R	R
Gearbox oil filler plug O-ring				I			I		
Engine oil filler plug O-ring	I	I	I	I	I	I	I	I	I
Fork plug O-ring					I				
Spark plugs		I	I	R	I	I	R		
Steering bearings and steering play	I	I	I	I	I	I	I	I	I
Wheel bearings - Wheels		I	I	I	I	I	I	I	I
Diagnosis by tool	I	I	I	I	I	I	I	I	I
Brake discs - Pads wear (4)	I	I	I	I	I	I	I	I	I
Air filter		R	R	R	R	R	R		
Engine oil filter	R	R	R	R	R	R	R	R	R
Vehicle general operation	I	I	I	I	I	I	I	I	I
Valve clearance	A	A	A	A	A	A	A		
Head cover gasket	I	I	I	I	I	I	I		
Gearbox oil discharge plug aluminium gasket				R			R		
Engine oil discharge plug aluminium gasket	R	R	R	R	R	R	R	R	R
Transmission oil discharge plug gasket				R			R		
Gasket for the engine oil filter fastening screw	R	R	R	R	R	R	R	R	R

Km x 1,000 (mi x 1,000)	1,5 (0.9)	10 (6.2)	20 (12.4)	30 (18.6)	40 (24.9)	50 (31.1)	60 (37.3)	EVER Y 12 MONT HS	EVER Y 24 MONT HS
Brake systems	I	I	I	I	I	I	I	I	I
Light circuit	I	I	I	I	I	I	I	I	I
Safety switches	I	I	I	I	I	I	I	I	I
Brake Fluid	I	I	I	I	I	I	I	I	R
Gearbox oil				R			R		
Fork oil (5)					R				
Engine oil (3)	R	R	R	R	R	R	R	R	R
Final drive oil				R			R		
Headlight aiming		I	I	I	I	I	I		
Fork oil seals (1)		I	I	I		I	I		
Tyres - pressure / wear (2)	I	I	I	I	I	I	I	I	I
Clutch clearance adjustment	A	A	A	A	A	A	A	A	A
Transmission oil filler plug washer				R			R		
Nut/bolt tightness	I	I	I	I	I	I	I		
Suspensions and stability			I		I		I	I	I
Head cover fastening screws dampers	I	I	I	I	I	I	I		
Filter box drain plug		C	C	C	C	C	C	C	C
Brake lines		I	I	I	I	I	I		

Km x 1,000 (mi x 1,000)	1,5 (0.9)	10 (6.2)	20 (12.4)	30 (18.6)	40 (24.9)	50 (31.1)	60 (37.3)	EVER Y 12 MONT HS	EVER Y 24 MONT HS
Fuel pipes									



The scheduled maintenance table refers to road use. If the new V85 is used for sports, in difficult conditions and on demanding roads, to correctly monitor the actual engine oil ageing there is an electronic device that registers the engine performance and allows predicting the need for maintenance.

For this purpose, when the maintenance icon (see the image) lights up steadily, you must contact a Moto Guzzi service centre to schedule the specific maintenance intervention. In this regard, we would like to remind you that operating the vehicle with degraded engine oil compromises the reliability of the mechanical organs, resulting in early damage and wear of the components.



### Recommended products (06\_03)

Piaggio Group recommends the use of products from its Castrol official partner for the scheduled maintenance of its vehicles.

Only use lubricants and fluids which meet or exceed the performance characteristics specified. This also applies when topping up only.

## TABLE OF RECOMMENDED PRODUCTS

Product	Description	Specifications
Engine oil 10W-60	Synthetic based lubricant for high performance four-stroke engines.	SAE 10W 60; JASO MA, MA2; API SG
75W-140 lubricant for gearboxes and transmissions	Synthetic lubricant for gearboxes and transmissions	SAE 75W-140 - API GL5
Fork oil 7.5W	Fork oil.	SAE 7.5W
Molybdenum disulphide grease	Lithium grease with molybdenum disulphide	Grey black grease.
Vaseline	neutral grease for battery terminals	-
Brake fluid DOT 4	Synthetic brake fluid.	SAE J 1703; FMVSS 116; ISO 4925; CUNA NC 956 DOT4

# TABLE OF CONTENTS

## **A**

ABS: 75  
Advanced functions: 35  
Air filter: 131  
Alarms: 28

## **B**

Battery: 11, 133, 136  
Brake: 11, 101, 132, 146  
Brake fluid: 11  
Brake pedal: 101

## **C**

Clutch: 101  
Clutch lever: 101

## **D**

Disc brake: 146  
Display: 23

## **E**

Engine oil: 10, 126, 128  
Engine stop: 72

## **F**

Fork: 98, 99  
Fuel: 8  
Fuses: 137

## **G**

Gearbox oil: 10, 129

## **H**

Headlight: 141  
Horn: 67

## **I**

Identification: 86  
Immobilizer: 82

Instrument panel: 21

## **M**

Maintenance: 125, 167, 168  
Maintenance Table: 168  
Mirrors: 144

## **O**

Oil filter: 128

## **R**

rear-view mirrors: 144  
Recommended products:  
171

## **S**

Saddle: 84  
Scheduled maintenance:  
168

Shock absorbers: 95, 96  
Spark plug: 131  
Stand: 113  
Start-up: 72  
Stop switch: 72

## **T**

Technical data: 157  
Turn indicators: 144  
Tyres: 129

## **U**

Use: 89

## **W**

Warning lights: 9



#### THE VALUE OF SERVICE

As a result of continuous updates and specific technical training programmes for Moto Guzzi products, only **Moto Guzzi** Official Network mechanics know this vehicle fully and have the specific tools necessary to carry out maintenance and repair operations correctly.

The reliability of the vehicle also depends on its mechanical conditions. Checking the vehicle before riding it, its regular maintenance and the use of **original Moto Guzzi spare parts** only are essential factors!

For information on the nearest **Official Dealer and/or Service Centre** consult our website:

[www.motoguzzi.com](http://www.motoguzzi.com)

Only by requesting Moto Guzzi original spare parts can you be sure of purchasing products that were developed and tested during the actual vehicle design stage. All Moto Guzzi original spare parts undergo quality control procedures to guarantee reliability and durability.

The descriptions and images in this publication are given for illustrative purposes only and are not binding.

While the basic characteristics as described and illustrated in this booklet remain unchanged, Piaggio & C. S.p.A. reserves the right, at any time and without being required to update this publication beforehand, to make any changes to components, parts or accessories, which it considers necessary to improve the product or which are required for manufacturing or construction reasons.

Not all versions/models shown in this publication are available in all countries. The availability of individual versions should be checked with the Official Moto Guzzi sales network.

The Moto Guzzi brand is owned by Piaggio & C. S.p.A.

© Copyright 2021 - Piaggio & C. S.p.A. All rights reserved. Reproduction of this publication in whole or in part is prohibited.

Piaggio & C. S.p.A. Viale Rinaldo Piaggio, 25 - 56025 PONTEDERA (PI), Italy

[www.piaggio.com](http://www.piaggio.com)