

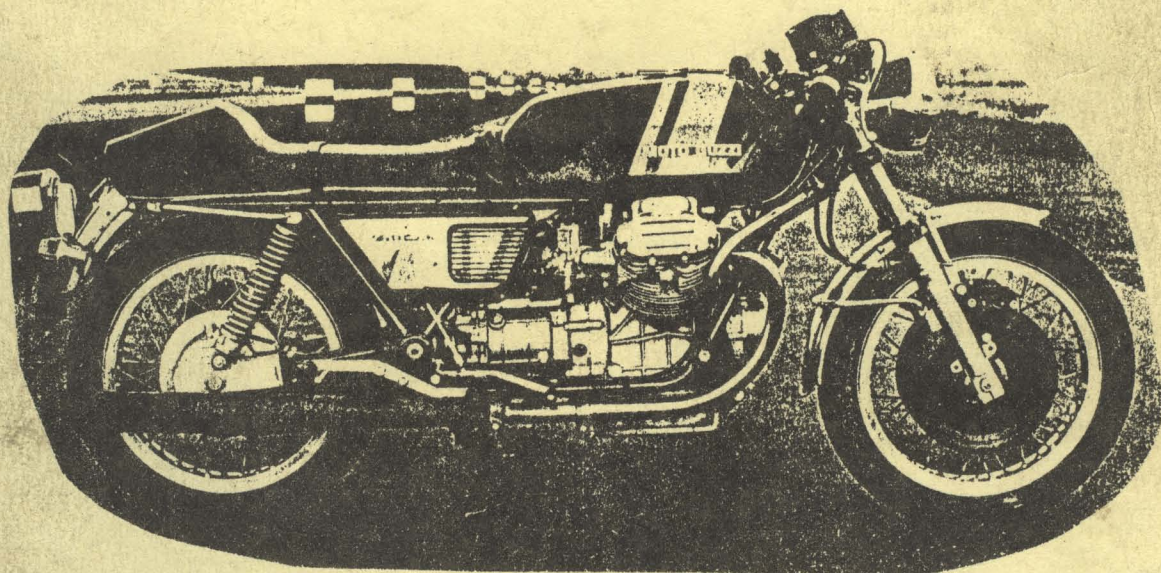

Ersatzteilkatalog "MOTO-GUZZI"
750 S3

Best.Nr. : 9200-1435

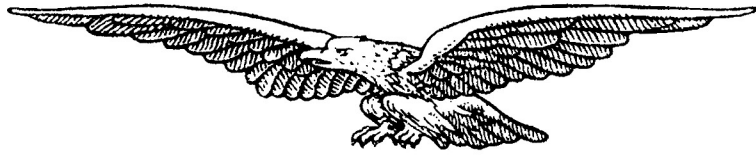



MOTO GUZZI

750 S3



VARIANTI PER 750 S3
MODIFICATIONS FOR 750 S3
VARIANTES POUR 750 S3
UMÄNDERUNGEN FÜR 750 S3

850 T3 (316.15)

TAVOLA 1



TAVOLA 4



TAVOLA 2

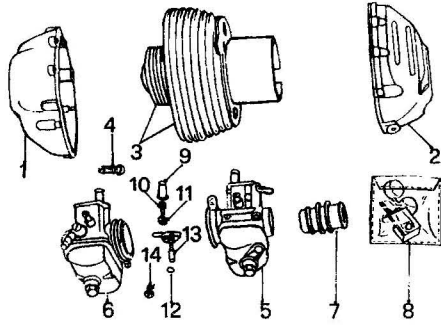

TAVOLA 10

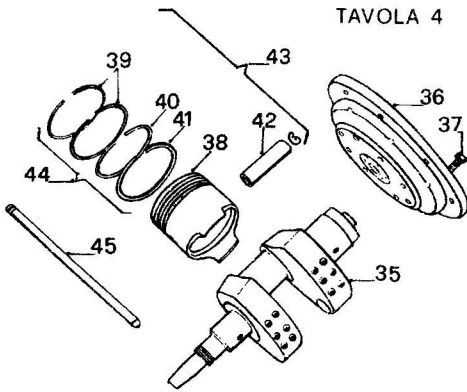

NOTE NOTES NOTES MARKE	POS. N.	N. COD. CODE No. No. CODE CODE Nr.	Q.tà Q.ty Q.té M.ge	DENOMINAZIONE	DESCRIPTION	DESIGNATION	BEZEICHNUNG
---------------------------------	------------	---	------------------------------	---------------	-------------	-------------	-------------

TAVOLA 1

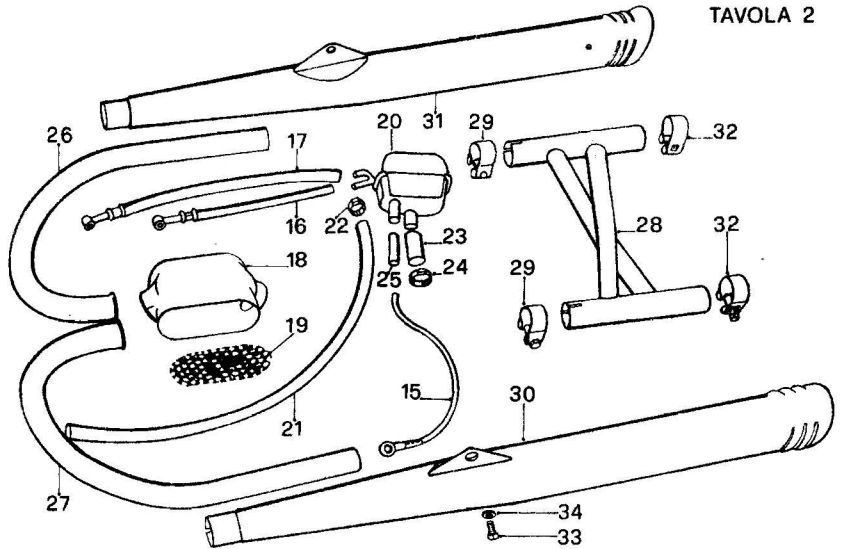
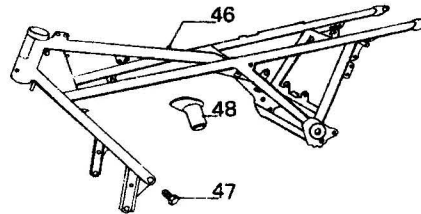
	1	14 02 35 50	1	Coperchio testa sn.	L.H. head cover	Couvercle de culasse G	Zylinderkopfdeckel, L.
	2	14 02 36 50	1	Coperchio testa ds.	R.H. head cover	Couvercle de culasse D	Zylinderkopfdeckel, R.
	3	14 06 01 01	2	Cilindro con pistone	Cylinder with piston	Cylindre avec piston	Zylinder mit Kolben
	4	17 03 40 50	4	Vite registro bilan.	Adjusting screw	Vis de réglage	Einstellschraube
	5	14 11 26 02	1	Carburatore ds.	R.H. carburetor	Carburateur D	Vergaser, R.
	6	14 11 26 03	1	Carburatore sn.	L.H. carburetor	Carburateur G	Vergaser, L.
	7	14 11 44 01	2	Cornetto per carburat.	Air funnel	Buse	Ansaugtrichter
	8	14 93 99 03	1	Gruppo revis. carbur.	Carb. overhauling kit	Kit de révis. du carb.	Verg. Reparatursatz
	9	13 93 70 00	1	Cappuccio	Cap	Chapeau	Schutzkappe
	10	12 93 72 00	1	Vite tendifilo	Adjusting screw	Vis de réglage	Stellschraube
	11	12 43 73 00	1	Dado bloccaggio	Nut	Ecrou	Mutter
	12	14 93 83 00	1	Guarnizione	Gasket	Joint	Dichtung
	13	14 93 78 00	1	Dispositivo avviam.	Starter	Démarrreur	Anlasser
	14	14 93 57 01	1	Getto massimo	Main jet	Gicleur principal	Hauptdüse

TAVOLA 2

	15	12 00 62 00	1	Tubaz. recupero olio	Return pipe	Tuyau de retour	Rücklaufrohr
	16	17 15 96 00	1	Tubaz. sfiatatoio tes.ds.	R.H. head breather	Reniflard culasse D	Entlüfterkopf, R.
	17	17 15 97 00	1	Tubaz. sfiatatoio tes.sn.	L.H. head breather	Reniflard culasse G	Entlüfterkopf, L.
	18	14 11 43 00	1	Manicotto elastico	Flexible sleeve	Manchon élastique	Elast. Passbuchse
	19	14 11 45 01	1	Fondello	Plug	Bouchon	Stopfen
	20	14 15 57 00	1	Sfiatatoio completo	Breather, complete	Reniflard complet	Entlüfter, kpl.
	21	95 98 51 36	1	Tubo per sfiato	Vent hose	Tuyau de reniflard	Entlüftungsschlauch
	22	12 15 79 00	1	Fascetta	Hose clamp	Collier	Schlauchschnelle
	23	14 15 74 00	1	Tubo elastico	Flexible pipe	Tuyau élastique	Elast. Rohr
	24	12 15 78 00	2	Fascetta	Hose clamp	Collier	Schlauchschnelle
	25	14 15 75 00	1	Tubo elastico	Flexible pipe	Tuyau élastique	Elast. Rohr
	26	14 12 09 45	1	Tubo scarico ds.	R.H. exhaust pipe	Tuyau d'échappem. D	Auspuffrohr R.
	27	14 12 09 46	1	Tubo scarico sn.	L.H. exhaust pipe	Tuyau d'échappem. G	Auspuffrohr L.
	28	14 12 39 00	1	Camera di espansione	Expansion chamber	Chambre de détente	Expansionsraum
	29	10 12 34 00	2	Fascetta	Clamp	Collier	Schlauchbinder
	30	14 12 29 45	1	Silenziatore sn.	L.H. muffler	Silencieux G	Schalldämpfer, L.

850 T3

(316.15)

VARIANTI PER 750 S3
 MODIFICATIONS FOR 750 S3
 VARIANTES POUR 750 S3
 UMÄNDERUNGEN FÜR 750 S3



TAVOLA 1



TAVOLA 4



TAVOLA 2

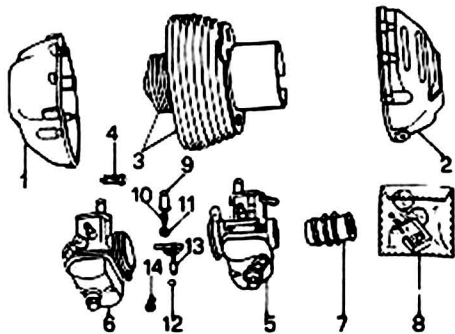

TAVOLA 10

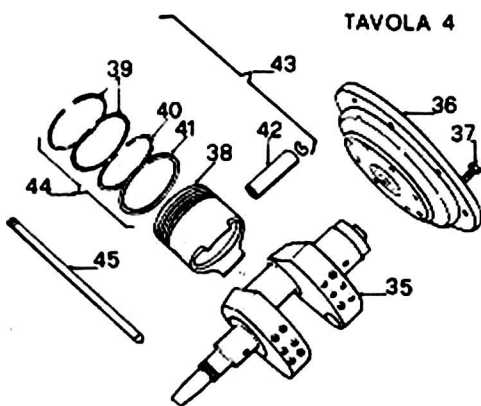

NOTE NOTES NOTES MARKE	POS. N.	N. COD CODE No. No. CODE CODE Nr	Q.ta Q.ty Q.te M.ge	DENOMINAZIONE	DESCRIPTION	DÉSIGNATION	BEZEICHNUNG
---------------------------------	------------	---	------------------------------	---------------	-------------	-------------	-------------

TAVOLA 2 (seguito)

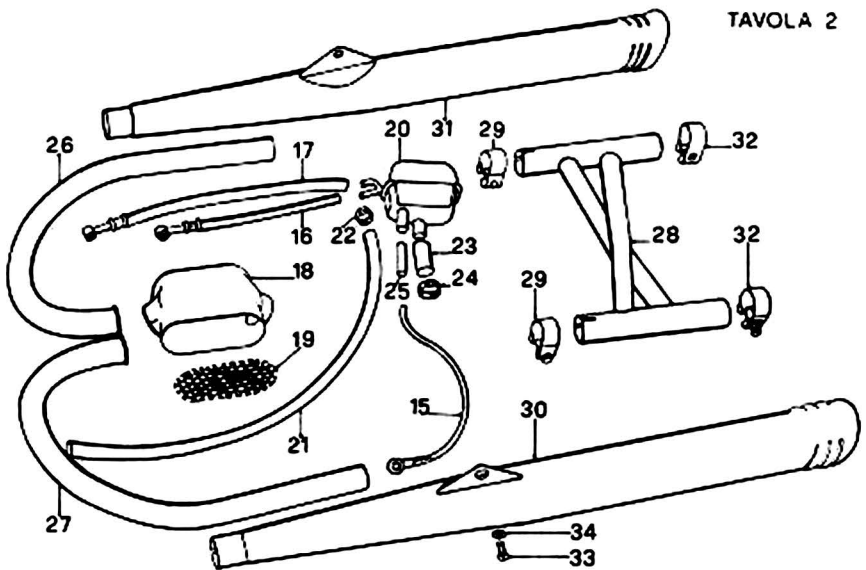
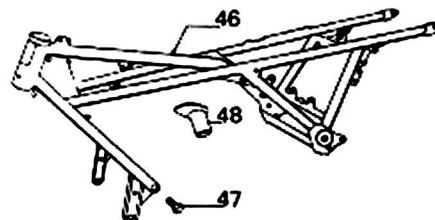
	31	14 12 30 45	1	Silenziatore ds.	R.H. muffler	Silencieux D	Schalldämpfer, R.
	32	14 12 69 00	2	Fascetta	Clamp	Collier	Schlauchbinder
	33	98 05 44 20	2	Vite	Screw	Vis	Schraube
	34	95 02 11 08	2	Rosetta elast. dentell.	Tooth washer	Rondelle dentée	Zahnscheibe

TAVOLA 3

		14 99 10 12	1	Motore	Engine	Moteur	Motor
		14 99 14 12	1	Motore completo di cambio	Engine with gearbox	Moteur avec boîte à vitesses	Motor mit Getriebe

TAVOLA 4

	35	14 06 42 00	1	Albero motore	Crankshaft	Vilbrequin	Kurbelwelle
	36	14 06 70 00	1	Volano motore	Flywheel	Volant moteur	Schwungrad
	37	98 05 44 20	8	Vite	Screw	Vis	Schraube
	38	14 06 04 00	2	Pistone	Piston	Piston	Kolben
	39	14 06 07 00	4	Fascia elastica super.	Piston ring	Segment d'étanchéité	Kolbenring
	40	14 06 08 00	2	Fascia elastica interm.	Piston ring	Segment d'étanchéité	Kolbenring
	41	14 06 09 00	2	Fascia elast. raschiaolio	Scraper ring	Segment racleur	Ölabstreifring
	42	12 06 12 00	2	Spinotto	Wrist pin	Axe de piston	Kolbenbolzen
	43	14 06 02 00	2	Pistone completo	Piston, assy	Piston complet	Kolben, kpl.
	44	14 06 06 00	2	Gruppo fasce elastiche	Piston rings set	Ensemble de segments	Kolbenringausrüstung
	45	17 04 50 50	4	Astina com. bilancieri	Tappet stem	Tige de poussoir	Stossstange

TAVOLA 10

	46	14 40 01 45	1	Telaio	Frame	Châssis	Rahmen
	47	98 05 44 16	2	Vite	Screw	Vis	Schraube
	48	14 42 45 00	1	Supporto tubaz. sfilato	Bracket	Support	Halter

	VARIANTI PER 750 S3 MODIFICATIONS FOR 750 S3 VARIANTES POUR 750 S3 UMÄNDERUNGEN FÜR 750 S3	<h1 style="margin:0;">850 T3</h1> (316.15)
---	---	---

TAVOLA 11



TAVOLA 12



NOTE NOTES NOTES MARKE	POS. N.	N. COD. CODE No. No. CODE CODE Nr.	Q.tà Q.ty Q.te M.ge	DENOMINAZIONE	DESCRIPTION	DESIGNATION	BEZEICHNUNG
---------------------------------	------------	---	------------------------------	---------------	-------------	-------------	-------------

TAVOLA 11

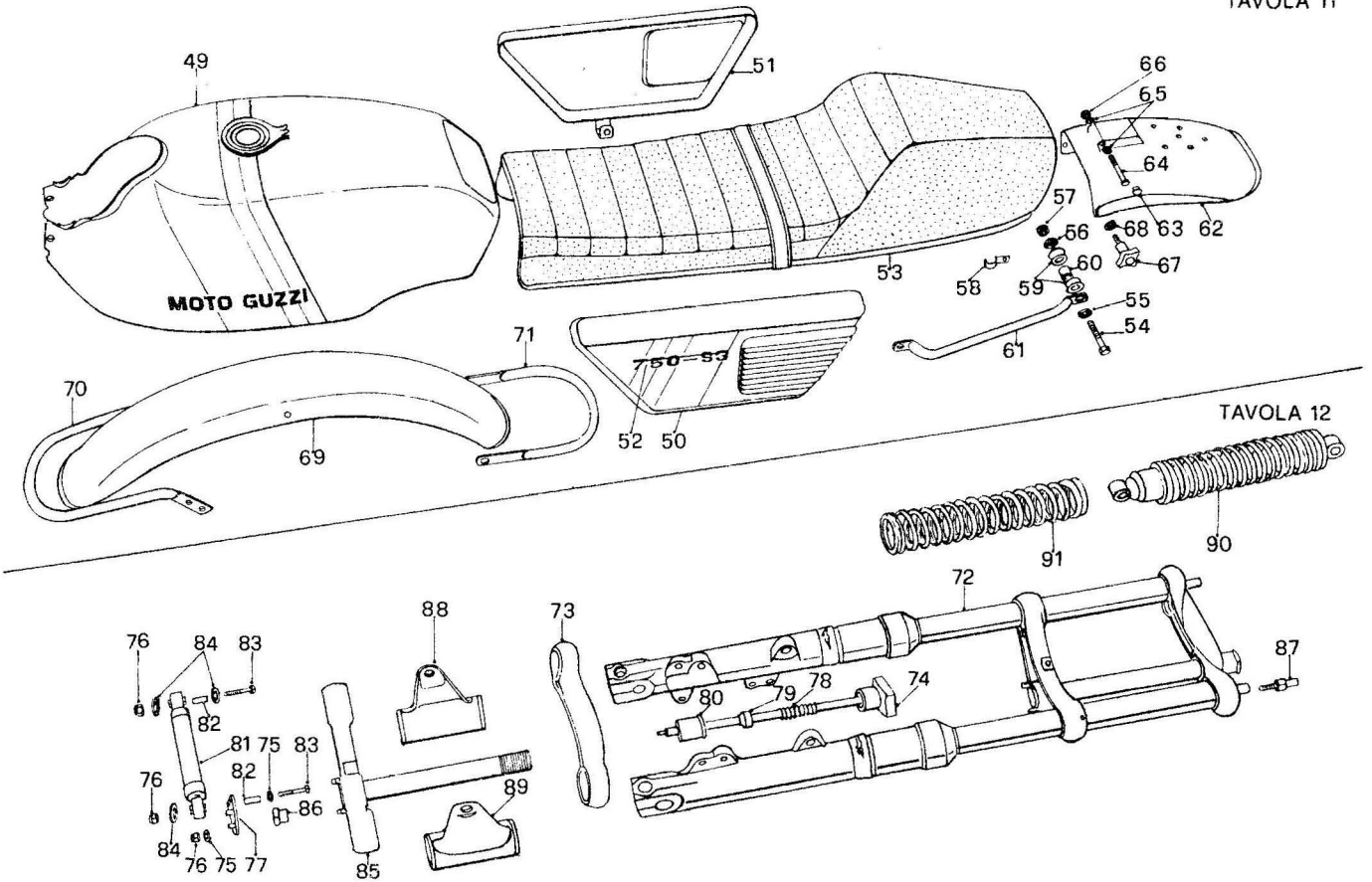
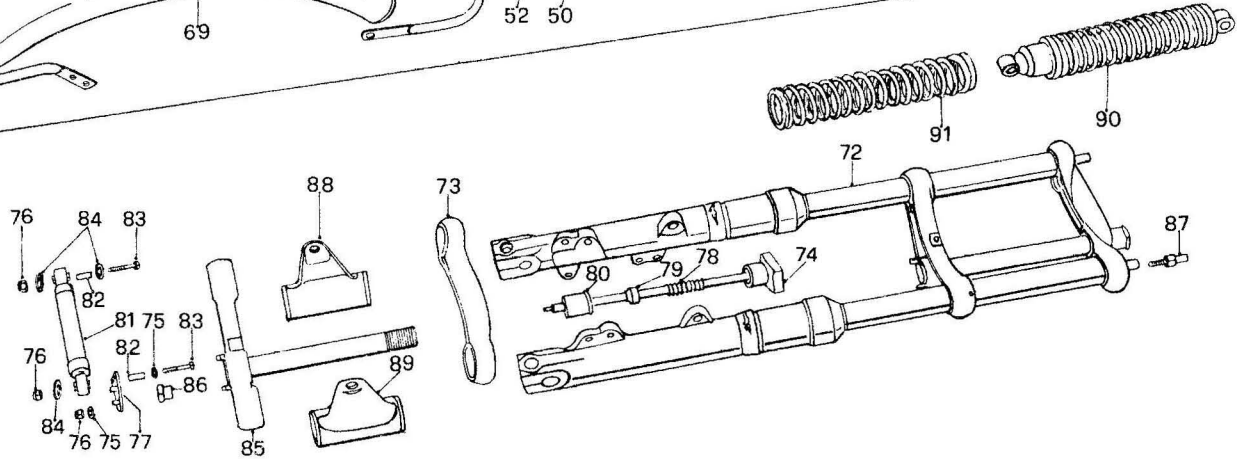
	49	14 10 02 45	1	Serbatoio carburante (nero - rosso)	Fuel tank (black - red)	Réservoir (noir - rouge)	Kraftstoffbehälter (Schwarz - Rot)
	49	14 10 02 46	1	Serbatoio carburante (nero - arancio)	Fuel tank (black - orange)	Réservoir (noir - orange)	Kraftstoffbehälter (Schwarz - Orange)
	49	14 10 02 47	1	Serbatoio carburante (nero - verde)	Fuel tank (black - green)	Réservoir (noir - vert)	Kraftstoffbehälter (Schwarz - Grün)
	50	14 47 63 45	1	Coperchio sn. (nero - rosso)	L.H. cover (black - red)	Couvercle G (noir - rouge)	Deckel L. (Schwarz - Rot)
	50	14 47 63 46	1	Coperchio sn. (nero - arancio)	L.H. cover (black - orange)	Couvercle G (noir - orange)	Deckel L. (Schwarz - Orange)
	50	14 47 63 47	1	Coperchio sn. (nero - verde)	L.H. cover (black - green)	Couvercle G (noir - vert)	Deckel L. (Schwarz - Grün)
	51	14 47 62 45	1	Coperchio ds. (nero - rosso)	R.H. cover (black - red)	Couvercle D (noir - rouge)	Deckel R. (Schwarz - Rot)
	51	14 47 62 46	1	Coperchio ds. (nero - arancio)	R.H. cover (black - orange)	Couvercle D (noir - orange)	Deckel R. (Schwarz - Orange)
	51	14 47 62 47	1	Coperchio ds. (nero - verde)	R.H. cover (black - green)	Couvercle D (noir - vert)	Deckel R. (Schwarz - Grün)
	52	14 92 20 45	2	Marchio per cop.	Mark	Marque	Marke
	53	14 46 05 45	1	Sella	Saddle	Selle	Sattel
	54	98 05 24 45	2	Vite	Screw	Vis	Schraube
	55	95 00 02 08	2	Rosetta	Washer	Rondelle	Scheibe
	56	95 00 42 08	2	Rosetta lato destro	R.H. washer	Rondelle D	Scheibe R.
	57	92 63 01 08	2	Dado autobloccante	Self-locking nut	Ecrou à autoblocage	Hutmutter
	58	93 30 13 15	1	Cavallotto	Bracket	Etrier	Bügel
	59	10 50 22 50	4	Elemento elastico	Rubber spacer	Anneau en caoutch.	Gummipuffer
	60	91 18 09 20	2	Bussola	Bush	Douille	Buchse
	61	14 46 43 00	2	Maniglia	Handle	Poignée	Hubhandgriff
	62	14 43 70 45	1	Appendice mobile post.	Rear mov. appendix	Appendice mob. AR	Hint. Beweglicheanlage
	63	93 18 00 60	2	Tappo	Plug	Bouchon	Stopfen
	64	98 05 23 55	1	Vite	Screw	Vis	Schraube
	65	95 00 02 06	2	Rosetta	Washer	Rondelle	Scheibe

850 T3

(316.15)

VARIANTI PER 750 S3
MODIFICATIONS FOR 750 S3
VARIANTES POUR 750 S3
UMÄNDERUNGEN FÜR 750 S3



TAVOLA 11



TAVOLA 12



NOTE NOTES NOTES MARKE	POS. N.	N. COD. CODE No. No. CODE CODE Nr	Q.tà Q.ty Q.té M.ge	DENOMINAZIONE	DESCRIPTION	DESIGNATION	BEZEICHNUNG
---------------------------------	------------	--	------------------------------	---------------	-------------	-------------	-------------

TAVOLA 11 (seguito)

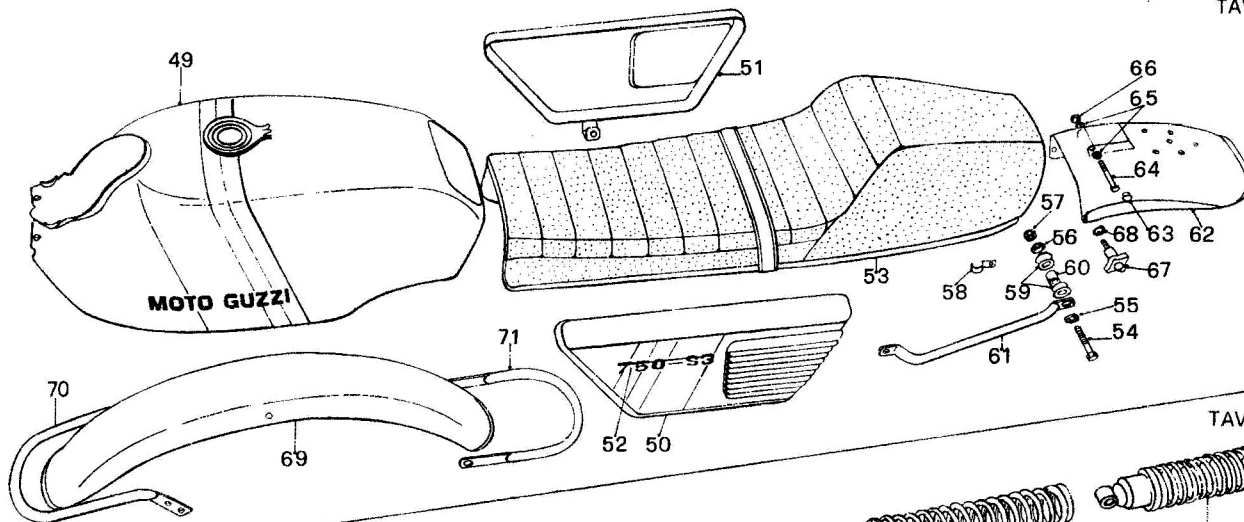
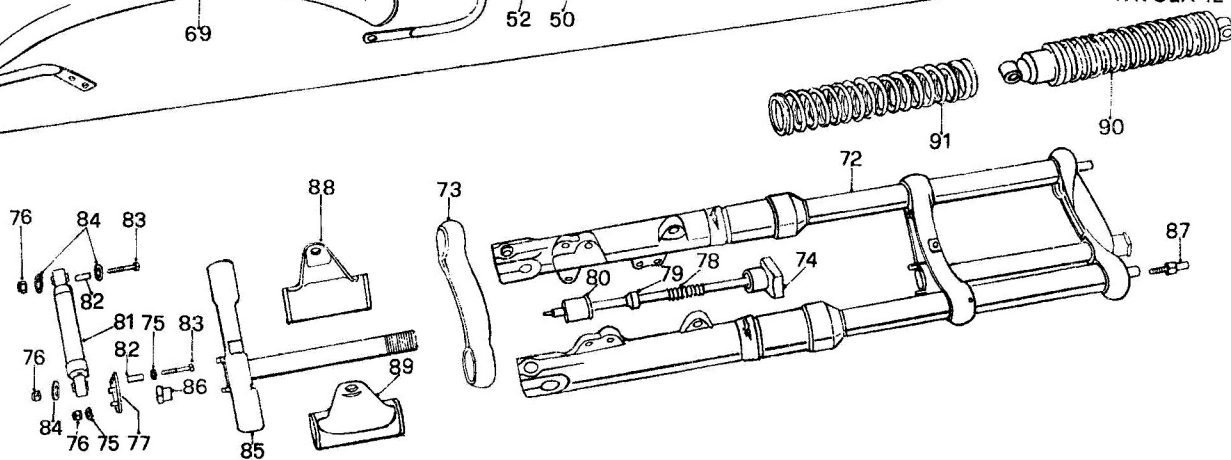
	66	92 63 01 06	1	Dado autobloccante	Nut	Ecrou	Mutter
	67	14 43 90 01	2	Vite a pomolo	Screw	Vis	Schraube
	68	14 43 98 00	2	Spessore	Spacer	Entretoise	Ausgleichblech
	69	14 43 44 45	1	Parafango anteriore	Front fender	Garde boue AV	Vordere Kotflügel
	70	14 43 46 45	1	Braccio anteriore	Front arm	Bras AV	Vorderer Arm
	71	14 43 50 20	1	Braccio posteriore	Rear arm	Bras AR	Hinterer Arm

TAVOLA 12

	72	14 49 02 45	1	Forcella anter. compl.	Front fork, compl.	Fourche AV compl.	Vordergabel, kpl.
	73	14 49 31 00	1	Testa di sterzo	Steering head	Tête de la col. de dir.	Lenkerkopf
	74	14 51 59 01	1	Asta per forcella	Rod	Tige	Stange
	75	95 00 02 06	2	Rosetta	Washer	Rondelle	Scheibe
	76	92 63 01 06	3	Dado autobloccante	Self-locking nut	Ecrou à autoblocage	Hutmutter
	77	14 51 89 00	1	Piastrina com. ammort.	Plate	Plaque	Plättchen
	78	14 51 62 00	1	Molla	Spring	Ressort	Feder
	79	14 51 71 00	1	Bussola	Bush	Douille	Buchse
	80	14 51 66 00	1	Bussola	Bush	Douille	Buchse
	81	14 53 02 01	1	Ammortizzat. sterzo	Steering damper	Amortisseur de direct.	Federpuffer
	82	14 53 08 00	2	Distanziale	Spacer	Entretoise	Distanzstück
	83	98 05 23 35	2	Vite	Screw	Vis	Schraube
	84	95 10 01 42	3	Rosetta di spessore	Shim	Rondelle d'épaisseur	Passscheibe
	85	14 49 40 50	1	Base forcella	Fork base	Socle de fourche	Gabelbasis
	86	14 49 43 00	1	Bussola	Bush	Douille	Buchse
	87	14 50 48 01	2	Vite	Screw	Vis	Schraube
	88	14 49 62 50	1	Fodero ds.	R.H. sleeve	Gaine D	Hülle R.
	89	14 49 61 50	1	Fodero sn.	L.H. sleeve	Gaine G	Hülle L.
	90	14 55 02 00	2	Sospensione poster.	Rear suspension	Suspension AR	Hint. Aufhängung
	91	14 55 23 01	2	Molla	Spring	Ressort	Feder

	VARIANTI PER 750 S3 MODIFICATIONS FOR 750 S3 VARIANTES POUR 750 S3 UMÄNDERUNGEN FÜR 750 S3	<h1 style="margin:0;">850 T3</h1> (316.15)
--	---	---

TAVOLA 13



TAVOLA 14



TAVOLA 15

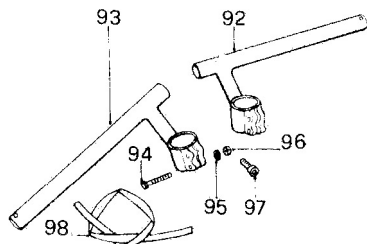

TAVOLA 16

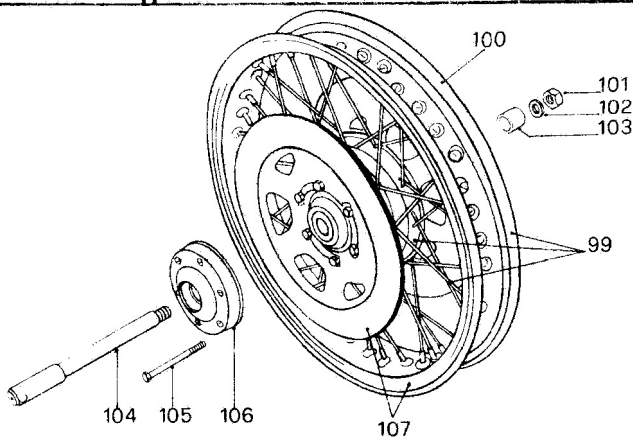

TAVOLA 17

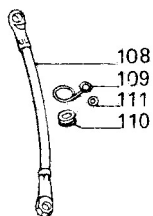

TAVOLA 18

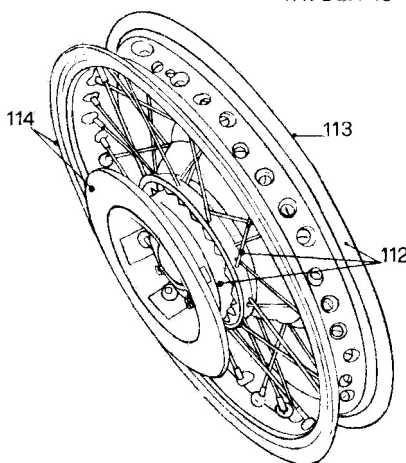

TAVOLA 19

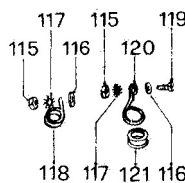

NOTE NOTES NOTES MARKE	POS. N.	N. COD. CODE No. No. CODE CODE Nr.	Q.ta Q. ty Q. te M. ge	DENOMINAZIONE	DESCRIPTION	DESIGNATION	BEZEICHNUNG
---------------------------------	------------	---	---------------------------------	---------------	-------------	-------------	-------------

TAVOLA 13

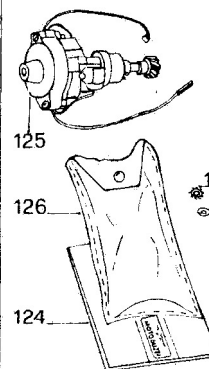
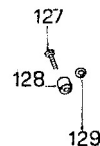
92	14 60 06 50	1	Semimanubrio ds.	R.H. half handle-bar	Demi-guidon D	Halblienkerstange R.
93	14 60 07 50	1	Semimanubrio sn.	L.H. half handle-bar	Demi-guidon G	Halblienkerstange L.
94	98 62 03 35	4	Vite	Screw	Vis	Schraube
95	95 10 01 19	4	Rosetta	Washer	Rondelle	Scheibe
96	92 63 01 06	4	Dado autobloccante	Self-locking nut	Ecrou à autoblocage	Hutmutter
97	98 62 24 16	2	Vite	Screw	Vis	Schraube
98	14 75 29 45	1	Guaina protezione	Cable hose	Gaine	Schutzschlauch

TAVOLA 14

99	14 61 03 01	1	Ruota anter. compl. di raggi e mozzo	Front wheel with spokes and hub	Roue AV avec moyeu et rayons	Vorderrad mit Nabe und Speiche
100	14 61 08 01	1	Cerchio	Wheel rim	Jante	Falge
101	92 60 33 16	1	Dado per perno	Wheel Nut	Ecrou	Mutter
102	95 00 52 17	1	Rosetta	Washer	Rondelle	Scheibe
103	14 61 63 20	1	Distanziale	Spacer	Entretoise	Distanzstück
104	14 61 41 20	1	Perno ruota	Wheel axle	Axe de roue	Radachse
105	98 05 24 95	6	Vite	Screw	Vis	Schraube
106	14 62 03 01	2	Flangia	Flange	Flasque	Flansch
107	14 61 02 20	1	Ruota anter. compl. senza perno, dado e rosetta	Front wheel compl. axle, nut and washer excl.	Roue AV compl. excl. axe, ecrou et rondelle	Vorderrad kpl. Achse, Mutter, und Scheibe aus.

TAVOLA 15

108	14 65 71 45	1	Tubazione flessibile	Flexible hose	Tuyau flexible	Bremsschlauch
109	14 43 65 45	2	Occhiello	Bracket	Support	Stütze
110	91 55 11 20	1	Anello gomma	Rubber grommet	Douille en caoutch.	Gummitülle
111	95 00 02 06	1	Rosetta esterna	Outside washer	Rondelle extérieure	Aussenscheibe

850 T3 (316.15)

VARIANTI PER 750 S3
MODIFICATIONS FOR 750 S3
VARIANTES POUR 750 S3
UMÄNDERUNGEN FÜR 750 S3



TAVOLA 13



TAVOLA 14



TAVOLA 15

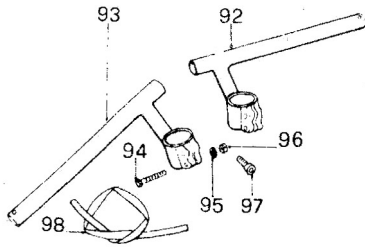

TAVOLA 16

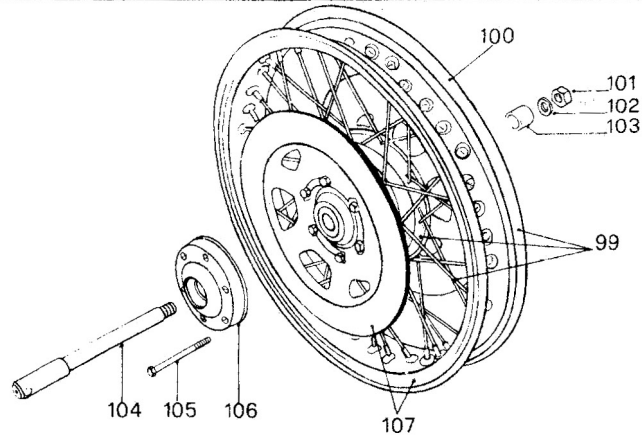

TAVOLA 17

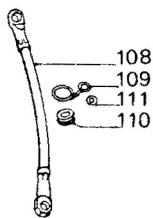

TAVOLA 18

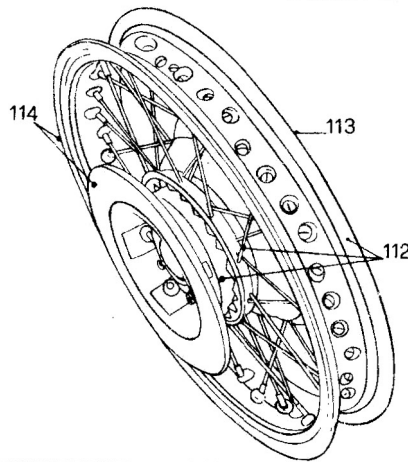

TAVOLA 19

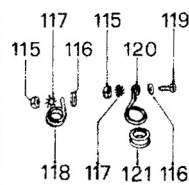

NOTE NOTES NOTES MARKE	POS. N.	N. COD. CODE No. No. CODE CODE Nr.	Q.ta Q.ty Q.te M.ge	DENOMINAZIONE	DESCRIPTION	DESIGNATION	BEZEICHNUNG
---------------------------------	------------	---	------------------------------	---------------	-------------	-------------	-------------

TAVOLA 16

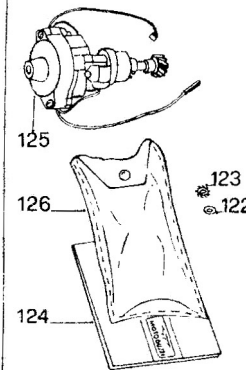
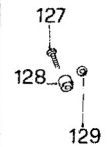
	112	17 63 06 50	1	Ruota poster. compl. di mozzo e raggi	Rear wheel with hub and spokes	Roue AR avec moyeu et rayons	Hinterrad mit Nabe und Speiche
	113	17 63 07 50	1	Cerchio	Wheel rim	Jante	Falge
	114	17 63 02 50	1	Ruota poster. compl. senza perno, dado e anelli	Rear wheel compl. axle, nut and rings exclud.	Roue AR compl. excl. axe, ecrou et anneau	Hinterrad kpl. Achse, Mutter und Rings aus.

TAVOLA 17

	115	92 60 22 06	6	Dado	Nut	Ecrou	Mutter
	116	95 00 02 06	6	Rosetta piana	Washer	Rondelle	Scheibe
	117	95 02 11 06	5	Rosetta dentelata	Tooth washer	Rondelle dentée	Zahnscheibe
	118	62 43 65 00	1	Sopperto tubazione	Bracket	Support	Stütze
	119	98 05 43 12	1	Vite	Screw	Vis	Schraube
	120	14 43 66 45	1	Occhiello	Bracket	Support	Stütze
	121	91 51 12 20	1	Anello gomma	Rubber grommet	Douille en caoutch.	Gummitülle

TAVOLA 18

	122	95 10 00 59	2	Rosetta piana	Washer	Rondelle	Scheibe
	123	95 02 11 05	2	Rosetta elastica	Spring washer	Rondelle élastique	Federring
	124	14 90 00 45	1	Libretto istruzioni	Rider's handbook	Manuel d'entretien	Betriebsanleitung
	125	14 71 54 00	1	Doppio ruttore con anticipo automatico	Distributor with regul.	Distributeur avec régul.	Zündverteiler mit Versteller
	126	14 92 99 00	1	Dotazione completa	Tool bag compl.	Trousse complète	Werkzeugtasche, kpl.

TAVOLA 19

	127	95 05 23 25	2	Vite	Screw	Vis	Schraube
	128	91 18 06 13	1	Distanziale	Spacer	Entretoise	Distanzstück
	129	95 10 00 59	4	Rosetta di spessore	Shim	Rondelle d'épaisseur	Passscheibe

SEIMM  MOTO GUZZI		NOTIZIARIO RICAMBI SPARE PARTS NEWS PIECES DETACHEES - NOUVELLES ERSATZTEILNACHRICHTER				RIASSUNTO MODIFICHE AL CATALOGO PARTI RICAMBIO SUMMARY OF MODIFICATIONS TO SPARE PARTS CATALOGUE RESUME MODIFICATIONS AU CATALOGUE PIECES DETACHEES ABÄNDERUNGSÜBERSICHT ZUM ERSATZTEILKATALOG			VARIANTI MODIFICATIONS VARIANTES UMÄNDERUNGEN	GIUGNO JUNE JUN 1976 JUNI
TAV. DRWG. TABLE BILD	POS. N.	Codice pre-mod. Pre-modif. code Code pre-mod. Vorveränderung	Q.TA' Q.TY Q.TE M.GE	Codice Modific. Modified code Code modifié Veränderte C.	Q.TA' Q.TY Q.TE M.GE	DENOMINAZIONE	DESCRIPTION	DESIGNATION	BEZEICHNUNG	NOTE NOTES NOTES MARKE
1	8	14 93 99 03	1	17 93 99 50	1	Gruppo revis. carbur.	Carburetor kit	Kit de carburateur	Vergaser - Rep. Satz	
4	38	14 06 04 00	2	14 06 04 45	2	Pistone	Piston	Piston	Kolben	
4	43	14 06 02 00	2	14 06 02 45	2	Pistone completo	Piston, compl.	Piston complet	Kolben, kpl.	
12	90	14 55 02 00	2	14 55 02 50	2	Sospensioni poster.	Rear suspensions	Suspensions AR	Hint. Aufhängung	
12	91	14 55 23 01	2	14 55 23 50	2	Molla per sospensioni	Spring	Ressort	Feder	
13	97	98 62 24 16	2	98 62 24 17	2	Vite fissaggio cruscotto	Screw	Vis	Schraube	
13				95 00 02 09	2	Ranella per vite	Washer	Rondelle	Scheibe	
14	105	98 05 24 05	6	98 05 24 98	6	Vite	Screw	Vis	Schraube	
17	121	91 51 12 20	1	91 55 11 20	1	Anello gomma	Rubber ring	Anneau en caoutch.	Gummiring	
18	125	14 71 54 00	1	14 71 54 40	1	Doppio ruttore ant. autom.	Front autom. distributor	Distributeur AV autom.	Vord. Zündverteiler	
19	127	95 05 23 25	2	98 05 23 25	2	Vite	Screw	Vis	Schraube	

SEIMM  MOTO GUZZI		NOTIZIARIO RICAMBI SPARE PARTS NEWS PIECES DETACHEES - NOUVELLES ERSATZTEILNACHRICHTER				RIASSUNTO MODIFICHE AL CATALOGO PARTI RICAMBIO SUMMARY OF MODIFICATIONS TO SPARE PARTS CATALOGUE RESUME MODIFICATIONS AU CATALOGUE PIECES DETACHEES ABÄNDERUNGSÜBERSICHT ZUM ERSATZTEILKATALOG			VARIANTI - MODIFICATIONS VARIANTES - UMÄNDERUNGEN CALIFORNIA POLIZIA LAPD (USA)	GIUGNO JUNE JUN 1976 JUNI
TAV. DRWG. TABLE BILD	POS. N.	Codice pre-mod. Pre-modif. code Code pre-mod. Vorveränderung	Q.TA' Q.TY Q.TE M.GE	Codice Modific. Modified code Code modifié Veränderte C.	Q.TA' Q.TY Q.TE M.GE	DENOMINAZIONE	DESCRIPTION	DESIGNATION	BEZEICHNUNG	NOTE NOTES NOTES MARKE
8	19	95 12 11 08	1	95 02 11 08	1	Rosetta dentellata	Tooth washer	Rondelle dentée	Zahnscheibe	
10	55/1	18 46 88 40	2	17 46 88 40	2	Supporto elastico	Flexible support	Support élast.	Elast. Halter	
12	74	17 49 02 50	1	17 49 02 51	1	Forcella anteriore compl.	Front fork, compl.	Fourche AV, compl.	Vordergabel, kpl.	
12	76	18 62 04 35	2	98 62 04 35	2	Vite	Screw	Vis	Schraube	
13	94/1	18 74 16 43	1	13 76 16 43	1	Tachimetro contamiglie	Speedometer (miles)	Compteur (miles)	Tacho (Meilen)	
13	95	13 76 04 43	1	13 76 06 43	1	Porta lampada per tachim.	Lamp socket	Douille d'ampoule	Glühlampenfassung	
13				18 76 38 50	1	Ghiera per azzeratore	Ring nut	Collier	Ring	
17	27			17 66 11 50	1	Coperchio pompa freni	Cover	Couvercle	Deckel	
19	121	17 74 49 40	1	17 47 49 40	1	Portatarga	Number plate holder	Support plaque de police	Kenne. Halter	



**NOTIZIARIO RICAMBI
SPARE PARTS NEWS
PIECES DETACHEES - NOUVELLES
ERSATZTEILNACHRICHTER**

**RIASSUNTO MODIFICHE AL CATALOGO PARTI RICAMBIO
SUMMARY OF MODIFICATIONS TO SPARE PARTS CATALOGUE
RESUME MODIFICATIONS AU CATALOGUE PIECES DETACHEES
ABÄNDERUNGSÜBERSICHT ZUM ERSATZTEILKATALOG**

850 T3

**GIUGNO
JUNE
JUN
1976**

TAV. DRWG. TABLE BILD	POS. N.	Codice pre-mod. Pre-modif. code Code pre-mod. Vorveränderung	Q.TA* Q.TY Q.TE M.GE	Codice Modific. Modified code Code modifié Veränderte C.	Q.TA* Q.TY Q.TE M.GE	DENOMINAZIONE	DESCRIPTION	DESIGNATION	BEZEICHNUNG	NOTE NOTES NOTES MARKE
1	47	90 70 60 80	6	90 70 71 83	6	Rosetta isolante	Washer	Rondelle	Scheibe	
1	75	13 93 65 00	1	13 93 66 00	1	Vite reg. valvola gas	Adjusting screw	Vis de réglage	Einstellschraube	
3	12	12 01 21 00	1	61 27 03 00	6	Rosetta elastica ondulata	Washer	Rondelle	Scheibe	
3	13	12 01 29 00	1	61 27 03 00	6	Rosetta elastica ondulata	Washer	Rondelle	Scheibe	
3	14	14 01 30 00	1	61 27 03 00	6	Rosetta elastica ondulata	Washer	Rondelle	Scheibe	
3	33	12 01 28 00	1	61 27 03 00	1	Rosetta elastica ondulata	Washer	Rondelle	Scheibe	
4	6	93 60 10 25	1	93 60 10 26	1	Ghiera bloccaggio	Ring nut	Fratte de blocage	Sicherungsring	
4	8	18 06 76 50	3	14 61 59 01	6	Rosetta	Washer	Rondelle	Scheibe	
4	17	12 06 20 00	4	12 06 20 05	4	Semicuscinetto di biella	Big-end half bearing	Demi-couss. de tête biella	Pluellagerschale	
4	17	12 06 20 01	4	12 06 20 06	4	Semicuscinetto (min; mm. 0,254)	Half-bearing (undersize mm. 0,254)	Demi-coussinet (minoré mm. 0,254)	Lagerschale (Untergrösse mm. 0,254)	
4	17	12 06 20 02	4	12 06 20 07	4	Semicuscinetto (min. mm. 0,508)	Half-bearing (undersize mm. 0,508)	Demi-coussinet (minoré mm. 0,508)	Lagerschale (Untergrösse mm. 0,508)	
4	17	12 06 20 03	4	12 06 20 08	4	Semicuscinetto (min. mm. 0,762)	Half-bearing (undersize mm. 0,762)	Demi-coussinet (minoré mm. 0,762)	Lagerschale (Untergrösse mm. 0,762)	
5	11	99 05 43 16	1	98 05 43 16	1	Vite	Screw	Vis	Schraube	
6	7	12 08 59 01	1	14 08 59 00	2	Tubetto intermedio	Rubber tube	Entretoise (caoutchouc)	Gummistück	
7	3	92 21 84 24	2	92 25 62 18	2	Cuscinetto A.P. e A.F.	M.S. & C.S. bearing	Roulement A.P. et A.E.	H.W. und K.W. Lager	
7	4	13 21 38 03	2	14 21 38 03	2	Piastrina di sicurezza	Lock plate	Plaque frein de sûreté	Schliessblech	
7	5	98 05 43 16	6	98 62 23 16	6	Vite	Screw	Vis	Schraube	
7	6	14 21 79 00	6	14 21 79 01	6	Piastrina di sicurezza	Lock plate	Plaque frein de sûreté	Schliessblech	
7	7	92 25 62 18	2	92 21 84 24	2	Cuscinetto A.F. e A.S.	C.S. & S.S. bearing	Roulement A.R. et A.I.	H.W. und V.W. Lager	
8	36	12 21 73 00	1	14 21 73 00	1	Rosetta di spallamento	Washer	Rondelle	Scheibe	
8	51	14 23 82 00	1	14 23 82 01	1	Molla richiamo presel.	Spring	Ressort	Feder	
8	66	17 25 27 50	1	17 25 25 70	1	Rosetta elastica ondulata	Washer	Rondelle	Scheibe	
9	12	12 32 80 01	1	17 32 80 50	1	Doppio giunto cardanico	Double joint	Joint double	Doppelverbindung	
10	7	95 00 02 08	2	95 10 02 55	2	Rosetta piana	Washer	Rondelle	Scheibe	
10	59	95 00 02 06	9	95 00 02 06	7	Rondella piana	Washer	Rondelle	Scheibe	
10				95 10 01 21	2	Ranella piana per tamb. serb.	Washer	Rondelle	Scheibe	
12	26	14 52 76 00	2	14 52 79 00	2	Estremità per asta	Tube end	Embout	Rohrende	
12	26			18 52 79 50	2	Estremità per asta	Tube end	Embout	Rohrende	
12	28	14 52 79 00		18 52 76 00	2	Scodellino inferiore	Lower cup	Coupelle infér.	Manschette	
12	29			18 52 66 50	2	Molla per forcella anter.	Spring	Ressort	Feder	
12	42	17 55 02 00	2	18 55 02 51	2	Sospensioni posteriori	Rear suspensions	Suspensions AR	Hiterradaufhäng.	
12	43	12 55 23 00	2	18 55 23 50	2	Molla sospensioni	Spring	Ressort	Feder	
12	45	17 55 23 00	8	18 55 16 50	8	Boccola in gomma	Rubber bush	Douille en caoutch.	Gummibüchse	
13	7	98 62 04 45	2	98 62 04 46	2	Vite	Screw	Vis	Schraube	
13	8	95 00 02 08	4	95 00 02 09	4	Rosetta	Washer	Rondelle	Scheibe	
13	26	17 60 34 00	1	14 60 34 50	1	Impugnatura gas	Throttle control	Comande de gaz	Gasregelung	
13	27	17 63 50 00	1	17 73 50 00	1	Interr. avv. e arr. motore	Starter switch & engine stop	Interr. démarr. et arr. mot.	Startersch. und Motorsp.	
15	1	17 66 02 52	1	17 66 02 53	1	Pompa freno anteriore	Front brake master cylinder	Maitre-cylindre frein AV	Vord. Hauptbremszyl.	
15	3	39 66 43 01	1	17 65 94 50	1	Gruppo revis. viti pompa ant.	Front pump screws kit	Kit de vis pompe AV	Vord. Pumpeschr. Rep. Satz	
15	4	98 62 03 25	1	17 65 94 50	1	Gruppo revis. viti pompa ant.	Front pump screws kit	Kit de vis pompe AV	Vord. Pumpeschr. Rep.-Satz	
15	5	61 01 38 00	1	17 65 94 50	1	Gruppo revis. viti pompa ant.	Front pump screws kit	Kit de vis pompe AV	Vord. Pumpeschr. Rep. Satz	
15	6	92 63 01 06	1	17 65 94 50	1	Gruppo revis. viti pompa ant.	Front pump screws kit	Kit de vis pompe AV	Vord. Pumpeschr. Rep. Satz	
15	31	17 66 11 52	1	17 66 13 52	1	Membrana a soffiutto	Membran	Membrane	Membran	
15	32	17 66 13 52	1	17 66 11 52	1	Coperchio	Cover	Couvercle	Deckel	



**NOTIZIARIO RICAMBI
SPARE PARTS NEWS
PIECES DETACHEES - NOUVELLES
ERSATZTEILNACHRICHTER**

**RIASSUNTO MODIFICHE AL CATALOGO PARTI RICAMBIO
SUMMARY OF MODIFICATIONS TO SPARE PARTS CATALOGUE
RESUME MODIFICATIONS AU CATALOGUE PIECES DETACHEES
ABÄNDERUNGSÜBERSICHT ZUM ERSATZTEILKATALOG**

850 T3

**GIUGNO
JUNE 1976
JUN
JUNI**

TAV. DRWG. TABLE BILD	POS. N.	Codice pre-mod. Pre-modif. code Code pre-mod. Vorveränderung	Q.TA' Q.TY Q.TE M.GE	Codice Modific. Modified code Code modifié Veränderte C.	Q.TA' Q.TY Q.TE M.GE	DENOMINAZIONE	DESCRIPTION	DESIGNATION	BEZEICHNUNG	NOTE NOTES NOTES MARKE
17	7	92 60 22 06	4	92 60 22 06	1	Dado	Nut	Ecrou	Mutter	
17				92 60 32 06	3	Dado	Nut	Ecrou	Mutter	
17	26	17 66 70 50	1	18 66 70 50	1	Pompa freni poster.	Rear brake master cylinder	Maître cylindre frein AR	Hint. Hauptbremszyl.	
17	27	17 66 11 50	1	18 66 11 50	1	Coperchio	Cover	Couvercle	Deckel	
17	28	17 66 13 50	1	14 66 13 00	1	Membrana a soffiello	Membran	Membrane	Membran	
17				14 65 94 50	1	Gruppo revis. viti pompa ant.	Front pump screws kit	Kit de vis pompe AV	Vord. Pumpeschr. Rep.Satz	
17	55	14 65 22 01	1	14 65 22 00	1	Pinza anteriore sx.	L.H. front caliper	Etrier AV G	Vorderfestsattel, L.	●
18	42			18 70 45 50	1	Batteria	Battery	Batterie	Deckel	
18	59	14 51 54 20	1	14 71 54 20	1	Coperchio	Cover	Couvercle	Deckel	
18	69	14 71 00 00	1	14 71 98 00	1	Gruppo rev. doppio rottore	Distributor kit	Kit de distributeur	Zundverteiler Rep.Satz	
19				17 74 04 62	1	Cablaggio fano	Wire assembly	Groupe de fils	Kabelsatz	
19	2	17 74 04 58	1	17 74 04 58	1	Calotta (senza cavi)	Body (without wire)	Boitier (sans fils)	Scheinw. (ohne Kabeln)	
19	40	13 60 96 60	11	13 60 96 60	19	Fascetta	Clamp	Collier	Schelle	
19				49 60 96 00	2	Fascetta fiss. trasmiss.	Clamp	Collier	Schelle	
20	5	17 74 04 28	1	17 74 04 28	1	Calotta (senza cavi)	Body (without wire)	Boitier (sans fils)	Scheinw. (ohne Kabeln)	
20				17 74 04 27	1	Cablaggio fano	Wire assembly	Groupe de fils	Kabelsatz	
21	9	17 67 63 24	1	17 47 63 24	1	Coperchio sx. (nero)	L.H. cover (black)	Couvercle G (noir)	Deckel, L. (schwarz)	
21	11	17 76 91 20	1	17 76 91 21	1	Supporto spie	Warning light support	Support témoin	Kontrollleuchte Halter	
22		17 47 99 00	1	17 45 99 00	1	Gruppo paraurti post. compl.	Rear bumper group, comp.	Groupe pare choc AR, comp.	Hint. Stossfänger Gr. kpl	
22				18 48 40 50	2	Serratura per borse later. completa di chiavi	Lock for side bags with keys	Serrure pour sacs latér. avec clés	Schloss für Tasche mit Schloßel	▲
22				18 48 25 21	2	Borsa later. (nera - decalcom. oro)	Side bag (black - gold transfer)	Sac latéral (noir - décalcom. or)	Seit. Tasche (schwarz - gold Abziehbild)	▲
22				18 48 25 55	2	Borsa laterale (nera - decal. bianca)	Side bag (black - white transfer)	Sac latéral (noir - décalcom. blanche)	Seit. Tasche (schwarz weiss Abziehbild)	▲
22				18 48 25 54	2	Borsa later. (argento chiaro)	Side bag (light silver)	Sac latér. (argent clair)	Seit. Tasche (helle Silber)	▲
22				18 48 25 56	2	Borsa later. (grigio azzurro metall. - decalcom. nera)	Side bag (blue grey - black transfer)	Sac latér. (gris bleu - décalcom. noir)	Seit. Tasche (blau-grau - schwarz Abziehbild)	▲
22				18 48 33 54	2	Coperchio borse (arg. chiaro)	Bag cover (light silver)	Couvercle sac (argent clair)	Taschedeck. (helle Silber)	▲
22				18 48 33 55	2	Coperchio borse (nero)	Bag cover (black)	Couvercle sac (noir)	Taschedeckel (schwarz)	▲
22				18 48 33 56	2	Coperchio borse (grigio azzurro metallizzato)	Bag cover (blue grey)	Couvercle sac (gris bleu)	Taschedeckel (blau-grau)	▲
22				17 48 00 21		Gruppo porta borse e borse laterali in plastica (nera decalcomania oro)	Bag holder and plastic bag group (black - gold transfer)	Groupe porte-sac et sacs en plastique (noir - décalcom. or)	Tascheträger - und Kunststofftaschen Gruppe (schwarz - gold Abziehbild)	▲
22				17 48 00 54		Gruppo porta borse e borse laterali in plastica (argento chiaro)	Bag holder and plastic bag group (light silver)	Groupe porte-sac et sacs en plastique (argent clair)	Tascheträger - und Kunststofftaschen Gruppe (helle Silber)	▲
22				17 48 00 55		Gruppo porta borse e borse laterali in plastica (nera - decalcomania bianca)	Bag holder and plastic bag group (black - white transfer)	Groupe porte sac et sacs en plastique (noir - décalcom. blanche)	Tascheträger - und Kunststofftaschen Gruppe (schwarz - weiss Abziehbild)	▲
22				17 48 00 56		Gruppo porta borse e borse laterali in plastica (grigio azzurro metallizzato)	Bag holder and plastic bag group (blue grey)	Groupe porte sac et sacs en plastique (gris-bleu)	Tascheträger - und Kunststofftaschen Gruppe (blau grau)	▲



**NOTIZIARIO RICAMBI
SPARE PARTS NEWS
PIECES DETACHEES - NOUVELLES
ERSATZTEILNACHRICHTER**

**RIASSUNTO MODIFICHE AL CATALOGO PARTI RICAMBIO
SUMMARY OF MODIFICATIONS TO SPARE PARTS CATALOGUE
RESUME MODIFICATIONS AU CATALOGUE PIECES DETACHEES
ABÄNDERUNGSÜBERSICHT ZUM ERSATZTEILKATALOG**

850 T3

**GIUGNO
JUNE
JUN 1976
JUNI**

TAV. DRWG. TABLE BILD	POS. N.	Codice pre-mod. Pre-modif. code Code pre-mod. Vorveränderung	Q.TA' Q.TY Q.TE M.GE	Codice Modific. Modified code Code modifié Veränderte C.	Q.TA' Q.TY Q.TE M.GE	DENOMINAZIONE	DESCRIPTION	DESIGNATION	BEZEICHNUNG	NOTE NOTES NOTES MARKE
22				17 99 98 54	1	Kit completo dei gruppi: parabrezza - borse laterali in plastica "argento chiaro" - paraurti posteriori	Compl. kit includes groups: windshield - "light silver" plastic bags - rear bar	Kit compl. comprenant les groupes: pare-brise - sacs en plastique "argent clair" - pare-choc AR	Komplett Kit, enthält die Gruppen: Windschutz - Kunststofftaschen "helle Silber" - Hinterstosstange	▲
22				17 99 98 55	1	Kit completo dei gruppi: parabrezza - borse laterali in plastica "nera - decalcom. bianche" paraurti poster.	Compl. kit includes groups: windshield - "black white transfer" plastic bags - rear bar	Kit compl. comprenant les groupes: pare-brise - sacs en plastique "noir - décalcom. blanche" - pare choc AR	Komplett Kit, enthält die Gruppen: Windschutz - Kunststofftaschen "schwarz - weiss Abziehbild" - Hinter- stosstange	▲
22				17 99 98 56	1	Kit completo dei gruppi: parabrezza - borse laterali in plastica "grigio azzurro met." paraurti poster.	Compl. kit includes groups: windshield - "blue grey" plastic bags - rear bar	Kit compl. comprenant les groupes: pare-brise - sacs en plastique "gris bleu" - pare- choc AR	Komplett Kit, enthält die Gruppen: Windschutz - Kunststofftaschen "bleu- grau" - Hinterstosstange	▲
22				17 99 98 21	1	Kit completo dei gruppi: parabrezza - borse laterali in plastica "nere - decal. oro" paraurti poster.	Compl. kit includes groups: windshield - "black - gold transfer" plastic bags - rear bar	Kit compl. comprenant les groupes: pare-brise - sacs en plastique "noir - décalcom. or" - pare-choc AR	Komplett Kit, enthält die Gruppen: Windschutz - Kunststofftaschen "schwarz gold Abziehbild" - Hinter- stosstange	▲

* Forniti su richiesta, sono intercambiabili - Available on request and interchangeable - Fournies sur demande, sont interchangeables - Geliefert auf Verlangen und auswechselbar

▲ Kit parabrezza, borse laterali, paraurti posteriori - Complete kit includes groups: windshield - side bags - rear bar
Kit complet comprenant les groupes: pare-brise, sacs latér. - pare-choc AR - Komplett Kit, enthält die Gruppen: Windschutz - Taschen - Hinterstosstange

● Per il tipo "850 T3" vale per i tappi senza attacchi elettrici - For 850 T3 type valid for plugs without electrical coupling -
Pour le type "850 T3" valable pour les bouchons sans branchements électriques - Für "850 T3" Typ Stopfen ohne elektrische Klemme