

MOTO GUZZI WOULD LIKE TO THANK YOU

for choosing one of its products. We have compiled this booklet to provide a comprehensive overview of your vehicle's quality features. Please read it carefully before riding the vehicle for the first time. It contains information, tips and precautions for using your vehicle. It also describes features, details and devices to assure you that you have made the right choice. We believe that if you follow our suggestions, you will soon get to know your new vehicle well and that it will continue to give you satisfactory service for many years to come. This booklet forms an integral part of the vehicle; should the vehicle be sold, it must be transferred to the new owner.

V9 Roamer - V9 Bobber



The instructions in this manual have been prepared to offer mainly a simple and clear guide to its use; it also describes routine maintenance procedures and regular checks that should be carried out on the vehicle at an **authorised Moto Guzzi Dealer or Workshop**. The booklet also contains instructions for simple repairs. Any operations not specifically described in this booklet require the use of special tools and/or particular technical knowledge; for these operations, please take your vehicle to an **authorised Moto Guzzi Dealer or Workshop**.



Personal safety

Failure to completely observe these instructions will result in serious risk of personal injury.



Safeguarding the environment

Sections marked with this symbol indicate the correct use of the vehicle to prevent damaging the environment.



Vehicle intactness

The incomplete or non-observance of these regulations leads to the risk of serious damage to the vehicle and sometimes even the invalidity of the guarantee

The symbols illustrated above are very important. They are used to highlight parts of the booklet that should be read with particular care. The different symbols are used to make each topic in the manual simple and quick to locate. Before starting the engine, read this booklet thoroughly and the "SAFE RIDING" section in particular. Your safety as well as other's does not only depend on the quickness of your reflexes and agility, but also on how well you know your vehicle, the state of maintenance of the vehicle itself and your knowledge of the rules for SAFE RIDING. For your safety, get to know your vehicle well so as to safely ride and master it in road traffic IMPORTANT This booklet is an integral part of the vehicle, and must be handed to the new owner in the event of sale.

INDEX

GENERAL RULES..... 7

- Foreword..... 8
- Motorcycle care..... 8
- Carbon monoxide..... 10
- Fuel..... 11
- Hot components..... 12
- Warning lights..... 12
- Used engine oil and gearbox oil..... 13
- Brake fluid..... 13
- Battery hydrogen gas and electrolyte..... 14
- Reporting of defects that affect safety..... 15

VEHICLE..... 17

- Arrangement of the main components..... 18
- Dashboard..... 23
- Instrument panel..... 23
- Light unit..... 24
- Digital lcd display..... 25
 - Alarms..... 26
 - Control buttons..... 27
 - Advanced functions..... 32
 - Ignition switch..... 37
 - Locking the steering wheel..... 38
- Horn button..... 38
- Switch direction indicators..... 39
- High/low beam selector..... 40
- Passing button..... 40
- Flasher button..... 41
- Start-up button..... 41
- Engine stop switch..... 42
- System ABS..... 42
- MGTC system(Moto Guzzi Controllo Trazione)..... 44
 - Opening the saddle..... 49
 - USB Port..... 49

- Identification..... 51

USE..... 53

- Checks..... 54
- Refuelling..... 57
- Rear shock absorbers adjustment..... 58
- Front fork adjustment..... 59
- Clutch lever adjustment..... 60
- Running in..... 61
- Moving off / riding..... 62
- Parking..... 63
- Catalytic silencer..... 63
- Stand..... 65
- Suggestion to prevent theft..... 66
- Safe driving..... 67
- Basic safety rules..... 68

MAINTENANCE..... 73

- Foreword..... 74
 - Engine oil level check..... 74
 - Engine oil top-up..... 76
 - Engine oil change..... 77
 - Bevel gear pair oil level..... 79
- Gearbox oil level..... 80
- Tyres..... 81
- Spark plug dismantlement..... 83
- Removing the sides..... 83
- Removing the air filter..... 84
- Checking the brake oil level..... 84
 - Braking system fluid top up..... 85
 - Use of a new battery..... 86
 - Checking the electrolyte level..... 87
 - Charging the battery..... 87
- Long periods of inactivity..... 88
- Fuses..... 89

Lamps.....	91
Headlight adjustment.....	93
Front direction indicators.....	95
Rear optical unit.....	96
Rear turn indicators.....	97
Rear-view mirrors.....	98
Front and rear disc brake.....	99
Periods of inactivity.....	101
Cleaning the vehicle.....	103
Transport.....	105
TECHNICAL DATA.....	107
PROGRAMMED MAINTENANCE.....	117
Scheduled maintenance table.....	118
Table of recommended products.....	121
SPECIAL FITTINGS.....	123
Accessories index.....	124

V9 Roamer - V9 Bobber



Chap. 01
General rules

Foreword

NOTE

CARRY OUT THE MAINTENANCE OPERATIONS AT HALF THE INTERVALS SPECIFIED IF THE VEHICLE IS USED IN WET OR DUSTY AREAS, OFF ROAD OR FOR SPORTING APPLICATIONS.

Motorcycle care

Moto Guzzi recommends using quality products for cleaning the vehicle. The use of unsuitable products can damage vehicle components. For cleaning do not use solvents such as "nitro thinner", "cold cleaning agents", or similar fuels, or cleaning products that contain alcohol.

WASHING THE MOTORCYCLE

Moto Guzzi recommends softening with water and then carefully removing the insects and stubborn stains before washing the vehicle.

To prevent stains, do not wash the motorcycle immediately after exposure to sunlight, and do not wash it in the sun.

If the vehicle is used during the winter months, be sure to frequently wash the motorcycle. To remove anti-icing salt sprayed on roads in the winter, wash the motorcycle with cold water immediately after use.

CAUTION

AFTER CLEANING YOUR MOTORCYCLE, THE EFFICIENCY OF THE BRAKING SYSTEM MAY BE TEMPORARILY AFFECTED DUE TO THE PRESENCE OF WATER ON THE FRICTION SURFACES. CONSIDER AN INCREASE IN BRAKING SPACE, OPERATE THE BRAKES REPEATEDLY TO RESTORE NORMAL CONDITIONS. CARRY OUT THE PRE-RIDE CHECKS BEFORE USE.



USE OF HOT WATER INTENSIFIES THE EFFECT OF THE SALT. USE ONLY PLENTY OF COLD WATER TO WASH AND REMOVE ANTI-ICING SALT



USE OF HIGH PRESSURE WASHING SYSTEMS (OR STEAM CLEANERS) CAN DAMAGE THE SEALS, OIL SEALS, BRAKING SYSTEM, ELECTRICAL SYSTEM AND THE SADDLE. DO NOT USE STEAM OR HIGH PRESSURE CLEANING SYSTEMS. DO NOT USE STEAM OR HIGH PRESSURE CLEANING SYSTEMS.

CLEANING OF SENSITIVE PARTS

BODYWORK

To keep the motorcycle bright, wash it regularly, especially if used in areas with high levels of pollution or mud. Aggressive stains from tree resins, gasoline, oil, brake fluid or bird excrement in general

must be removed immediately, otherwise permanent stains on the paint can appear. After washing it is easy to identify marks and residual stains, remove them from the body using a soft cloth and brand-name, non-abrasive polish, and protect with a protective wax for cars. Periodic care, a thorough cleaning and regular protective wax for the bodywork preserves the aesthetic quality of the motorcycle over the long term.

PLASTIC COMPONENTS



IF THE PLASTIC COMPONENTS ARE CLEANED USING AGGRESSIVE AGENTS, THE SURFACE MAY BE DAMAGED. DO NOT USE CLEANING PRODUCTS CONTAINING ALCOHOL, SOLVENTS OR THAT ARE ABRASIVE FOR THE CLEANING

OF PLASTIC PARTS. ROTARY BRUSHES OR SPONGES WITH HARD SURFACES CAN MAKE SCRATCHES

CHROME PARTS AND POLISHED METAL



TREAT THE PARTS MADE OF CHROME, ALUMINIUM OR POLISHED STEEL IN A SPECIAL MANNER. WASH THEM WITH PLENTY OF WATER AND CAR SHAMPOO, POLISH AND REGULARLY BRIGHTEN THEM WITH POLISH PASTE, PROTECT THEM WITH WAXES OR SUITABLE ACID-FREE PRODUCTS (E.G. VASELINE)

RUBBER PARTS

Clean the rubber parts using water and mild shampoo (brand-name, suitable for car bodies)



THE USE OF SILICONE SPRAY TO CLEAN THE RUBBER SEALS MAY CAUSE DAMAGE. DO NOT USE OTHER PRODUCTS CONTAINING SILICON FOR CLEANING THE MOTORCYCLE

Carbon monoxide

If you need to keep the engine running in order to perform a procedure, please ensure that you do so in an open or very well ventilated area. Never let the engine run in an enclosed area. If you do work in an enclosed area, make sure to use a smoke-extraction system.

CAUTION

EXHAUST EMISSIONS CONTAIN CARBON MONOXIDE, A POISONOUS GAS WHICH CAN CAUSE LOSS OF CONSCIOUSNESS AND EVEN DEATH.

CAUTION

CARBON MONOXIDE IS ODOURLESS AND COLOURLESS, THEREFORE IT CANNOT BE DETECTED BY SMELL, SIGHT OR OTHER SENSES. DO NOT BREATHE IN EXHAUST FUMES UNDER ANY CIRCUMSTANCES.

Fuel**CAUTION**

THE FUEL USED TO POWER INTERNAL COMBUSTION ENGINES IS HIGHLY FLAMMABLE AND MAY BE EXPLOSIVE UNDER CERTAIN CONDITIONS. IT IS THEREFORE RECOMMENDED TO CARRY OUT REFUELLING AND MAINTENANCE PROCEDURES IN A VENTILATED AREA WITH THE ENGINE SWITCHED OFF. DO NOT SMOKE DURING REFUELLING OR NEAR FUEL VAPOUR. AVOID ANY CONTACT WITH NAKED FLAME, SPARKS OR OTHER HEAT SOURCES WHICH MAY CAUSE IGNITION OR EXPLOSION.

DO NOT ALLOW FUEL TO DISPERSE INTO THE ENVIRONMENT.

KEEP OUT OF THE REACH OF CHILDREN.



IF THE VEHICLE FALLS OR IS ON A STEEP INCLINE FUEL CAN LEAK.

Hot components

The engine and the exhaust system components get very hot and remain in this condition for a certain time interval after the engine has been switched off. Before handling these components, make sure that you are wearing insulating gloves or wait until the engine and the exhaust system have cooled down.

Warning lights



IF THE ALARM WARNING LAMPS ILLUMINATE DURING THE NORMAL ENGINE OPERATION, THIS MEANS THAT THE ELECTRONIC CONTROL UNIT HAS FOUND AN ABNORMALITY.



IF THE GENERAL ALARM WARNING LAMP FLASHES DURING THE NORMAL ENGINE OPERATION, THIS MEANS THAT THE OIL PRESSURE IN THE CIRCUIT IS INSUFFICIENT.

IN THIS CASE THE ENGINE MUST BE SHUT OFF IMMEDIATELY IN ORDER TO PREVENT POSSIBLE DAMAGE.



PERFORM THE MOTOR OIL LEVEL CHECK. IF THE INSUFFICIENT MOTOR OIL PRESSURE LIGHT REMAINS DESPITE THE ABOVE PROCEDURE BEING PER-

FORMED CORRECTLY, CONTACT AN AUTHORIZED Moto Guzzi Dealer TO HAVE THE SYSTEM CHECKED.

Used engine oil and gearbox oil

CAUTION



IT IS ADVISABLE TO WEAR PROTECTIVE IMPERMEABLE GLOVES WHEN SERVICING THE VEHICLE.

THE ENGINE OR GEARBOX OIL MAY CAUSE SERIOUS INJURIES TO THE SKIN IF HANDLED FOR PROLONGED PERIODS OF TIME AND ON A REGULAR BASIS.

WASH YOUR HANDS CAREFULLY AFTER HANDLING OIL.

HAND THE OIL OVER TO OR HAVE IT COLLECTED BY THE NEAREST USED OIL RECYCLING COMPANY OR THE SUPPLIER.

DO NOT DISPOSE OF OIL IN THE ENVIRONMENT

KEEP OUT OF THE REACH OF CHILDREN

Brake fluid



BRAKE FLUID MAY BE HARMFUL TO PAINTWORK, PLASTIC AND RUBBER. WHEN SERVICING THE BRAKING SYSTEM PROTECT THESE COMPONENTS WITH A CLEAN CLOTH. ALWAYS WEAR PROTECTIVE GOGGLES WHEN SERVICING THESE SYSTEMS. BRAKE FLUID IS EXTREMELY HARMFUL TO THE

EYES. IN THE EVENT OF ACCIDENTAL CONTACT WITH THE EYES, RINSE THEM IMMEDIATELY WITH ABUNDANT COLD, CLEAN WATER AND SEEK MEDICAL ADVICE.

KEEP OUT OF THE REACH OF CHILDREN

Battery hydrogen gas and electrolyte

CAUTION



THE BATTERY ELECTROLYTE IS TOXIC, CORROSIVE AND AS IT CONTAINS SULPHURIC ACID, IT CAN CAUSE BURNS WHEN IN CONTACT WITH THE SKIN. WHEN HANDLING BATTERY ELECTROLYTE, WEAR TIGHT-FITTING GLOVES AND PROTECTIVE APPAREL. IN THE EVENT OF SKIN CONTACT WITH THE ELECTROLYTIC FLUID, RINSE WELL WITH PLENTY OF CLEAN WATER. IT IS PARTICULARLY IMPORTANT TO PROTECT YOUR EYES BECAUSE EVEN TINY AMOUNTS OF BATTERY ACID MAY CAUSE BLINDNESS. SEEK SPECIALISED MEDICAL ATTENTION IMMEDIATELY IN THE EVENT OF CONTACT WITH THE EYES. THE BATTERY RELEASES EXPLOSIVE GASES; KEEP IT AWAY FROM FLAMES, SPARKS, CIGARETTES OR ANY OTHER HEAT SOURCES. ENSURE ADEQUATE VENTILATION WHEN SERVICING OR RECHARGING THE BATTERY.

KEEP OUT OF THE REACH OF CHILDREN.

BATTERY LIQUID IS CORROSIVE. DO NOT POUR IT OR SPILL IT, PARTICULARLY ON PLASTIC COMPONENTS. ENSURE THAT THE ELECTROLYTIC ACID IS COMPATIBLE WITH THE BATTERY TO BE ACTIVATED.

Reporting of defects that affect safety

Unless otherwise specified in this Use and Maintenance Booklet, do not remove any mechanical or electrical component.

CAUTION

SOME CONNECTORS IN THE VEHICLE MAY BE ACCIDENTALLY SWAPPED AND MAY COMPROMISE NORMAL VEHICLE OPERATION IF INCORRECTLY INSTALLED.

V9 Roamer - V9 Bobber



**Chap. 02
Vehicle**

Arrangement of the main components (02_01, 02_02, 02_03, 02_04)

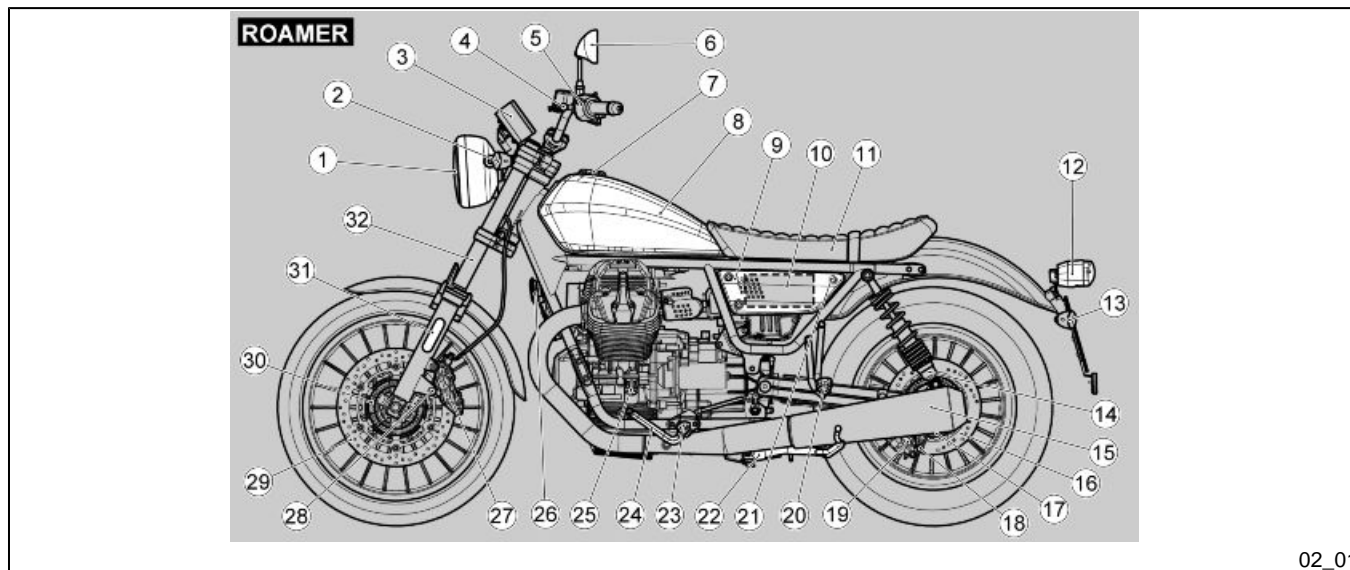

02_01

ROAMER

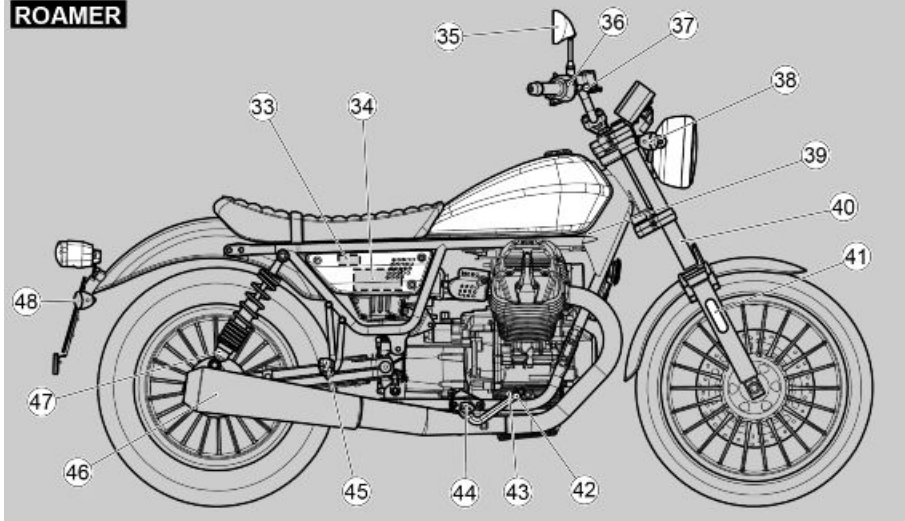

02_02

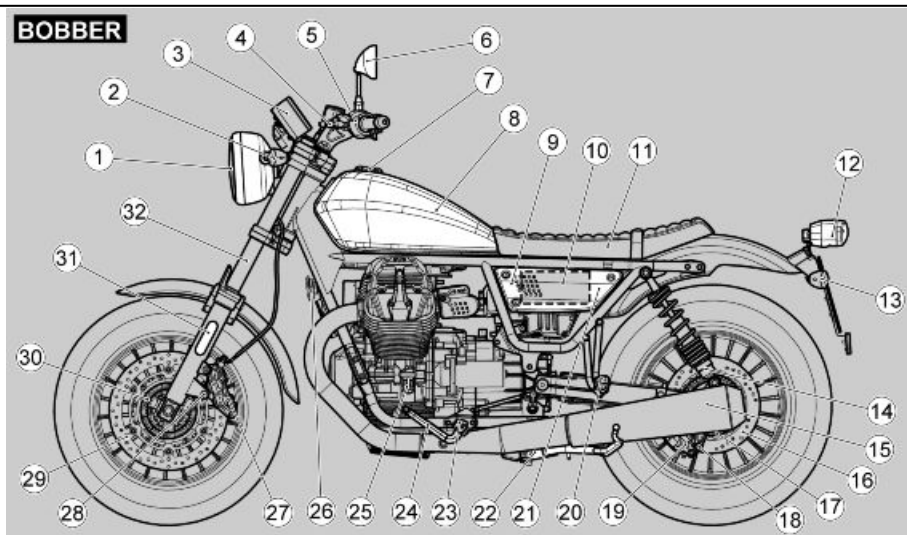

02_03

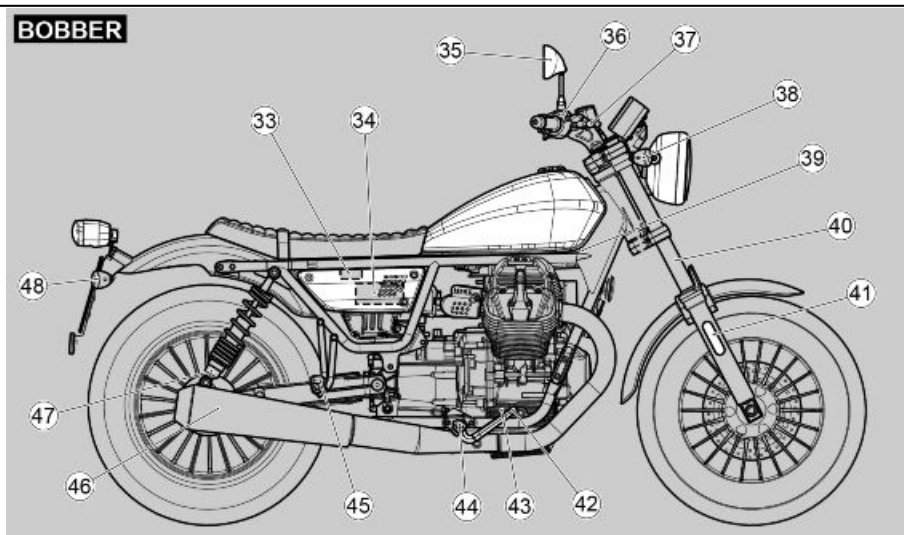

02_04

Key - V9 Roamer/V9 Bobber:

1. Headlamp
2. Front left turn indicator
3. Instrument panel
4. Clutch lever
5. Left light switch
6. Left rear-view mirror
7. Fuel tank cap
8. Fuel tank
9. Left side fairing
10. Air filter
11. Saddle
12. Taillight
13. Rear left turn indicator

14. Rear left shock absorber
15. Left silencer
16. Rear brake disc
17. Rear tone wheel
18. Rear speed sensor
19. Rear brake calliper
20. Passenger left footrest
21. Seat lock
22. Side stand
23. Left rider footrest
24. Gear shift lever
25. Engine oil level dipstick
26. Horn
27. Front brake calliper
28. Front speed sensor
29. Front brake disc
30. Front tone wheel
31. Left hand reflector
32. Front left fork
33. Fuse box
34. Battery
35. Right rear-view mirror
36. Right hand light switch
37. Front brake fluid reservoir
38. Front brake lever
39. Front right turn indicator
40. USB port
41. Front right fork
42. Right hand reflector
43. Rear brake lever
44. Rear brake fluid reservoir
45. Right rider footrest
46. Right passenger footrest
47. Exhaust muffler
48. Rear right shock absorber
49. Rear right turn indicator

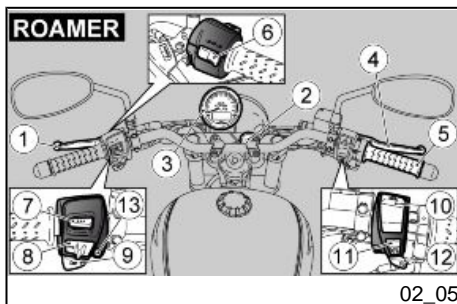

Dashboard (02_05, 02_06)

Key:

1. Clutch control lever
2. Ignition switch /steering lock
3. Instruments and gauges
4. Front brake lever
5. Throttle grip
6. High beam flashing switch
7. MODE switch
8. Turn indicator switch
9. Horn button
10. Emergency tell-tale light button
11. Engine stop switch
12. Engine start switch
13. MGCT switch

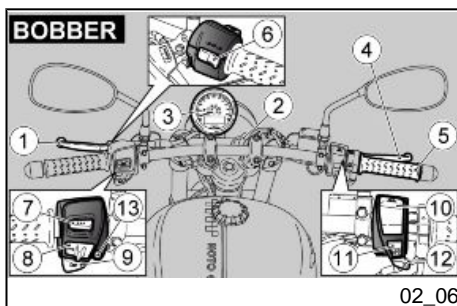

Instrument panel (02_07, 02_08)

key:

1. Multifunctional digital display
2. Odometer
3. Warning lights

NOTE

**INFORMATION ON THE DIGITAL DISPLAY (1) IS AVAILABLE IN ENGLISH ONLY.
THE LANGUAGE USED CANNOT BE CHANGED.**

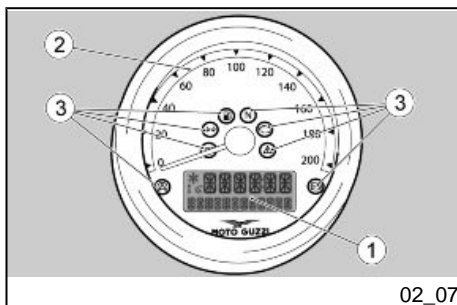

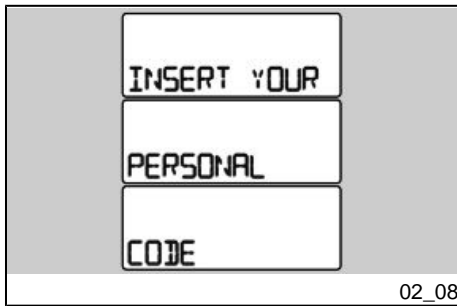

The instrument panel has an immobilizer system which prevents start-up in case the system does not identify a key which has been stored before.

The vehicle is supplied with two keys already programmed. The instrument panel saves a maximum of four keys: contact an Official **Moto Guzzi** dealer to enable these keys or to disable a key that has been lost. After delivery of a new vehicle, the instrument panel displays the message "INSERT YOUR PERSONAL CODE" when the ignition switch is turned to on, prompting the user to enter a personal five-figure code. This request is no longer displayed once the personal code is entered. See the paragraph "CONTROL BUTTONS" for the procedure for entering the code

It is important to remember the personal code because:

- **the vehicle can be started if the immobilizer system is faulty**
- **the instrument panel need not be replaced should the ignition switch be changed**
- **new keys can be programmed**

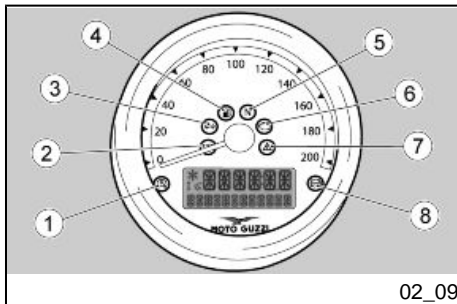

Light unit (02_09)

key:

1. MGCT warning light (amber yellow)
2. High beam warning light (blue)
3. Turn indicator warning light (green)
4. Amber low fuel warning light (yellow)
5. Neutral gear warning light (green)
6. MI general alarm warning lamp (amber)
7. General alarm warning lamp (red)
8. ABS warning light (amber)

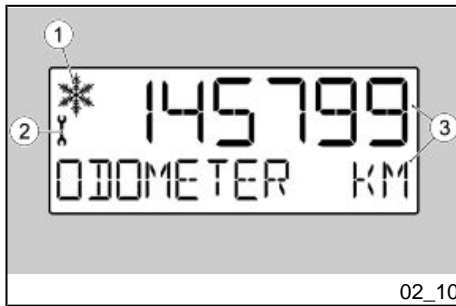

Digital Lcd display (02_10, 02_11, 02_12, 02_13)

- By turning the ignition key to "ON", the system works as follows:
 - all indicator lamps illuminate simultaneously for three seconds (lamp check);
 - it resets the position of all the needles, which afterwards go to the bottom of the scale and return to zero;
 - the backlight is temporarily set to maximum brightness;
 - all indicator lamps are extinguished (except active indicator lamps), the brightness setting set previously by the user is restored and the normal display mode is restored.

The standard settings that can be viewed on the display are:

- 1) Ice alarm (may be displayed with temperatures equal to or below 3°C / 37.4°F);
- 2) Maintenance icon
- 3) Trip computer log or alarms stored
- 4) Gear selected (calculated) (*)

(*) The selected gear is calculated from the vehicle speed and engine speed values. If the clutch lever is applied or if the vehicle is stationary, this calculation is not possible and the symbol "-" is displayed.

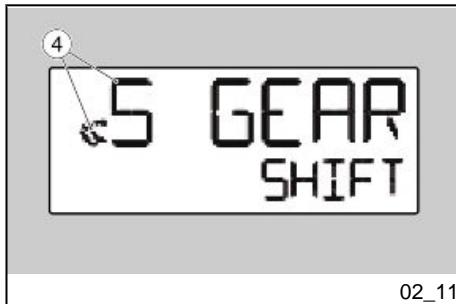

Ice warning alarm

The ice symbol is shown at the top left of the LCD display if the external temperature is 3°C / 37.4°F or lower. Ride with extreme care.

When this temperature rises the symbol will disappear.

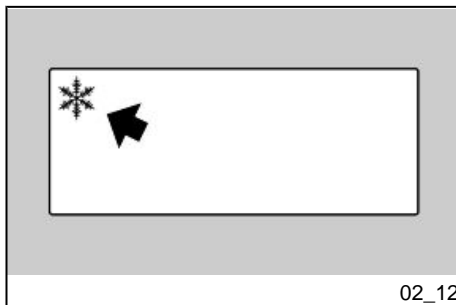

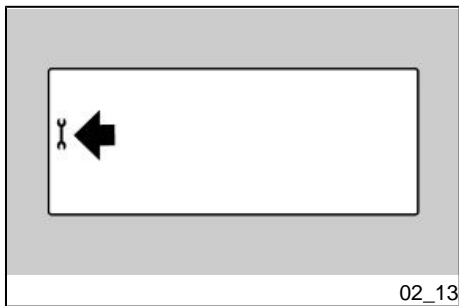

Maintenance icons

- The system displays the function as follows:
 - when a maintenance interval threshold is exceeded, an icon with a spanner is shown on the LCD display.
 - Consult an Official **Moto Guzzi** Dealer to reset Service.

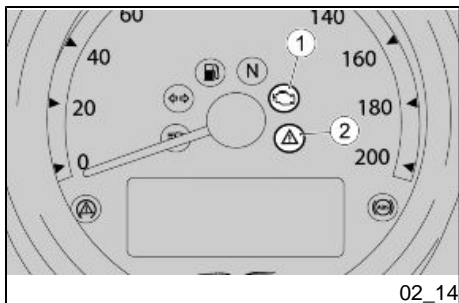

Alarms (02_14, 02_15)

If the instrument panel or ECU detect a digital display fault, when alarm descriptions are displayed, the warning lamp MI (1) and the general alarm warning lamp (2) also illuminate.

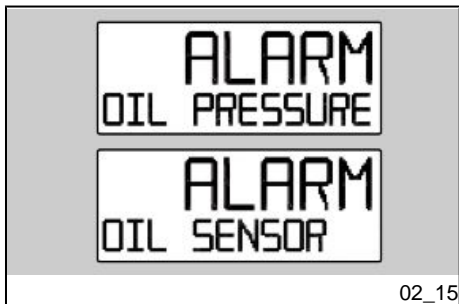

Oil pressure and Oil sensor

In the event of an oil pressure fault or if the oil pressure sensor is disconnected, the message "ALARM OIL PRESSURE" or "ALARM OIL SENSOR" is shown on the display. The general alarm warning lamp (2) lights steadily if the fault is relative to the oil pressure sensor, and flashes if the alarm is relative to oil pressure.

CAUTION

ALARM OIL PRESSURE: IN CASE OF INSUFFICIENT PRESSURE, THE WARNING LIGHT FLASHES. SWITCH OFF THE ENGINE IMMEDIATELY AND TAKE THE

MOTORCYCLE TO AN Official Moto Guzzi Dealer USING A ROADSIDE ASSISTANCE VEHICLE.

ALARM OIL SENSOR: IN CASE OF FAULT OF THE OIL PRESSURE SENSOR, THE WARNING LIGHT REMAINS ON STEADY. AS SOON AS POSSIBLE BRING THE MOTORCYCLE TO AN Official Moto Guzzi Dealership.

When an alarm is shown on the display, press the "MODE" selector to return to the trip journal information display mode. After 10 seconds, the information relative to the alarm displayed beforehand returns to the foreground on the digital display.

Control buttons (02_16, 02_17, 02_18, 02_19, 02_20, 02_21, 02_22, 02_23, 02_24, 02_25, 02_26)

- Press the "MODE" selector briefly up or down to scroll between the menu options.
- Press the "MODE" selector to reset the trip journal parameter or confirm the selected parameter.

Press the selector to cycle through the following functions in sequence:

- 1) TOTAL ODOMETER (ODOMETER)
- 2) TRIP ODOMETER "1" (TRIP)
- 3) TRIP ODOMETER "2" (TRIP)
- 4) RIDING TIME (TIME)
- 5) AVERAGE SPEED (AVERAGE)
- 6) AVERAGE FUEL CONSUMPTION (AVG FUEL)
- 7) CURRENT FUEL CONSUMPTION (FUEL)
- 8) EXTERNAL TEMPERATURE (TEMP)
- 9) CLOCK (CLOCK)

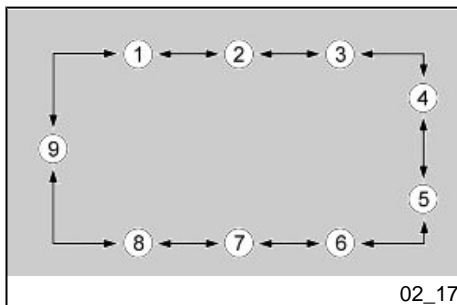
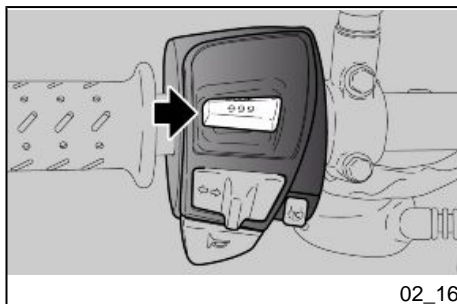



Total odometer (Odometer)

Unit of measurement for the counter: Km or Miles.

- View: on LCD display.

- This value is stored permanently.
- It cannot be reset.
- Selected gear cannot be displayed (gear is calculated by system).
- The total odometer mode is as shown in the figure:

- once the value reaches 999999, the odometer count does not reset to zero.



Trip odometer (Trip/Trip D)

Unit of measurement for the counter: Km or Miles.

- View: on LCD display.

- This value is stored.
- Press and hold the centre of the "MODE" selector to reset the "TRIP" and "TRIP D" trip odometer values. "TRIP D" is also reset eight after ignition off.
- The trip odometer display mode is as shown in the figure:

- the message "TRIP" or "TRIP D" is shown;

- if the value exceeds 999.9, the counter is reset and starts from "0.0" again.

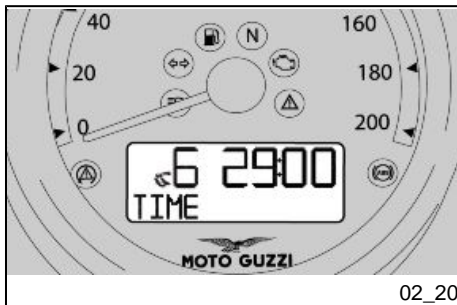

Riding time (Time)

Unit of measurement for the counter: hours and minutes (hh:mm).

- View: on LCD display.

- This value is stored.
- Press and hold the "MODE" selector to reset the counter. Disconnecting and reconnecting the battery also resets the counter.
- This parameter is displayed as shown in the figure:

- the message "TIME" is displayed.

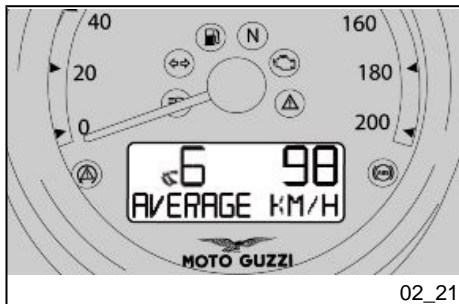

Average speed (Average)

Unit of measurement for the counter: Km/h or mph.

- View: on LCD display.

- This value is stored.
- Press and hold the "MODE" selector to reset the counter. Disconnecting and reconnecting the battery also resets the counter.
- This parameter is displayed as shown in the figure:

- the message "AVERAGE KM/H" or "AVERAGE MPH" is displayed.

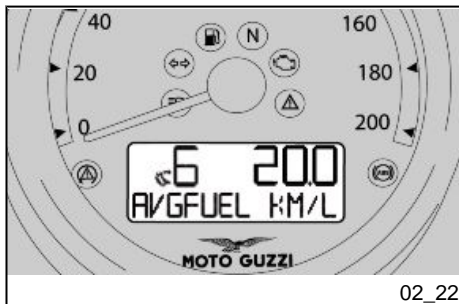

Average fuel consumption (Avg fuel)

Unit of measurement for the counter: Km/l, L/100 km, US mpg or IMP mpg

- View: on LCD display.

- This value is stored.
- Press and hold the "MODE" selector to reset the value.
- This parameter is displayed as shown in the figure:

- the message "AVERAGE KM/L", "AVERAGE L/100" or "AVERAGE MPG" is displayed.

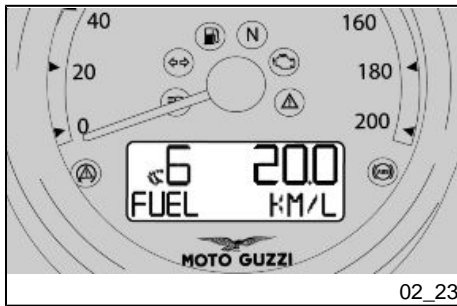

Current fuel consumption (Fuel)

Unit of measurement for the counter: Km/l, L/100 km, US mpg or IMP mpg

- View: on LCD display.

- The value is reset to 0.0 at each key-on
- This parameter is displayed as shown in the figure:

- the message "FUEL KM/L", "FUEL L/100" or "FUEL MPG" is displayed.

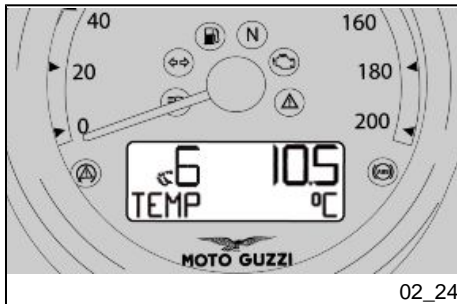

External temperature

Unit of measurement: °C or °F.

- View: on LCD display.

The displayable range is -15 / +50 °C (5 / 122 °F).

- If the temperature is below -15 °C (5 °F), the symbol "-" is shown steadily on the LCD display.
- If the value is between -15°C (5 °F) and +50°C (122 °F), the correct value is shown steadily on the display.
- If the temperature is equal to or below +3 °C (37.4 °F), the "ICE WARNING ALARM" symbol is shown on the LCD display.

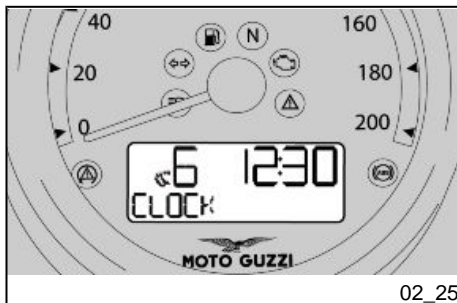

Clock (Clock)

Unit of measurement for the counter: hours and minutes (hh:mm)

- View: on LCD display.

- This value is stored.
 - The data is reset when reconnecting the battery.
 - This parameter is displayed as shown in the figure:
- the message "CLOCK" is displayed.

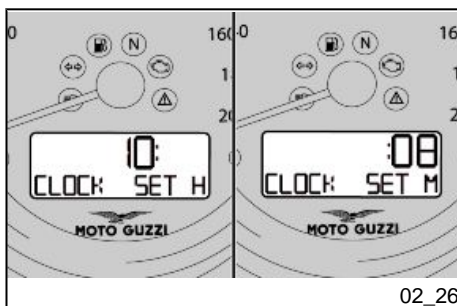

Clock adjustment

The clock time is set from the "CLOCK" function. Press and hold the "MODE" selector to access the function. Each time the selector is pressed up or down increases or decreases the hour value by one unit. Once the value 12 is reached, pressing up returns to 1, while pressing down with the value 1 displayed returns to 12.

Press and hold the centre of the selector to store the value and select minute adjustment mode.

Each time the selector is pressed up or down increases or decreases the minutes value by one unit. Once the value 59 is reached, pressing up returns to 0, while pressing down with the value 1 displayed returns to 59.

Press and hold the selector to exit the function. Alternatively, the system exits the function once the vehicle speed exceeds 5 Km/h.

CAUTION



FOR THE SAFETY OF THE RIDER AND PASSENGER, THESE PROCEDURES ARE ONLY POSSIBLE WITH THE VEHICLE AT A STANDSTILL.

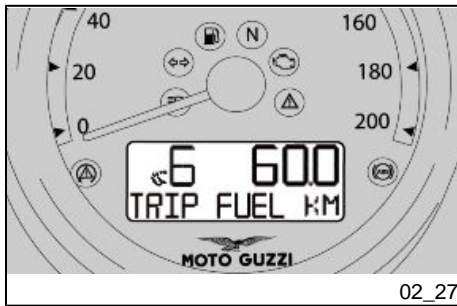

02_27

Advanced functions (02_27, 02_28, 02_29, 02_30, 02_31, 02_32, 02_33, 02_34, 02_35, 02_36)

Trip Fuel "Distance travelled in reserve"

This function counts and displays the distance travelled in Km or miles with the vehicle in fuel reserve.

When the low fuel warning light turns on:

- the "TRIP FUEL" counter appears on the LCD display after 2 Km (1.24 mi);
- pressing the "MODE" selector again returns to the trip journal display mode.

If the ignition key is set to "ON":

- the "TRIP FUEL" counter is not displayed the first sixty seconds (reserve level sensor stabilisation). Once this period has elapsed, the "TRIP FUEL" counter is displayed automatically. The "TRIP FUEL" counter is displayed as shown in the figure:

- the message "TRIP FUEL" appears;
- the initial value is "0.0".

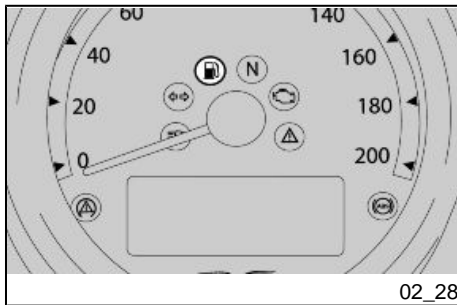

02_28

Fuel "Reserve fuel indicator"

When the vehicle is in fuel RESERVE:

- the reserve fuel warning indicator activates automatically on the LCD display.
- The reserve fuel warning indicator appears during the initial check cycle.

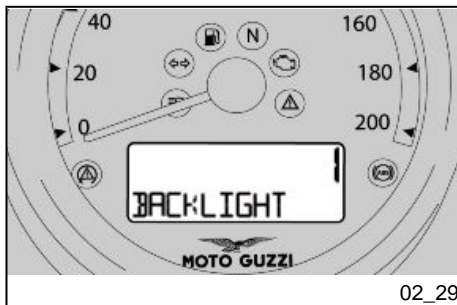

Backlight "Instrument backlighting adjustment"

Backlighting of instruments and gauges (needles of scales and displays) can be adjusted at three levels.

This parameter may be adjusted during the initial check cycle. Press the centre of the "MODE" selector briefly to access the function. Press the "MODE" selector up or down to cycle through the three levels available:

- 1 (Minimum)
- 2 (Medium)
- 3 (Maximum)

After three seconds with no input from the "MODE" selector, or once the vehicle speed exceeds 5 Km/h (3.11 mph), the value is stored and the display returns to trip journal mode.

Instrument panel configuration

Press and hold the centre of the "MODE" when in "ODOMETER" mode to access the following advanced functions:

- 1) Gear shift indicator threshold (SET GEAR SHIFT)
- 2) Change user code (USER CODE MODIFICATION)
- 3) Recover user code (USER CODE RECOVERY)
- 4) Change odometer unit of measurement (SELECT UNIT (Km/mi))
- 5) Change consumption indicator unit of measurement (SELECT UNIT (L/100 - Km/L - US mpg - IMP mpg))
- 6) Change thermometer unit of measurement (SET UNIT °C - °F)



Gear Shift "gear shift indicator threshold"

The gear shift indicator threshold is set in this mode.

Press and hold the "MODE" selector to access the setting mode from the menu. Press the "MODE" button up or down to select the required setting.

- SET GEAR SHIFT L: 4500 rpm (run-in revolutions)
- SET GEAR SHIFT H: 8000 rpm

For each threshold setting, each upward press of the selector increases the value by 100 rpm, and each downward press decreases the value by 100 rpm. Press and hold the "MODE" selector to save the value set, exit the mode and return to the configuration menu.



At the first key-on after setting, the instrument panel applies the last value set. When the engine speed threshold set is exceeded, the message "GEAR SHIFT" is shown on the display and the general alarm warning lamp lights. The general alarm warning lamp flashes when the lower threshold value is exceeded, and lights steadily when the upper threshold is exceeded. The general alarm warning lamp extinguishes once the engine speed drops below the threshold set.

The number of maximum engine revisions is 6800 rpm.

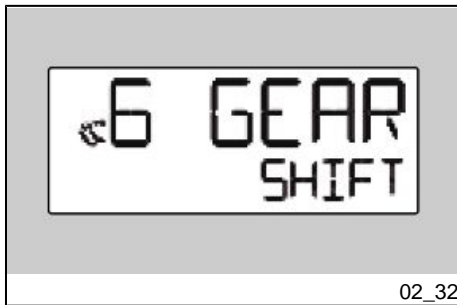

User Code Modification "Change user code"

The user code enables engine start even in the event of an immobiliser system fault. The user code is set by default as five zeros (00000) on a new vehicle, and the message "INSERT YOUR PERSONAL CODE" is shown on the display for ten seconds. The "USER CODE MODIFICATION" function may be used to change the code and stop the message from being displayed. The value displayed for the figure on the furthest left hand side of the LCD cycles between 0 and 9. Press the centre of the "MODE" selector briefly to confirm each of the five figures. Once the code is confirmed, the new code is shown steadily on the display to let the user verify that the code has been entered correctly. Turn the ignition off and then on again to unlock the instrument panel.

The last code set may be modified again in future. Access the setting mode again, enter the last user code used (OLD CODE), then enter a new user code (NEW CODE) as described previously.

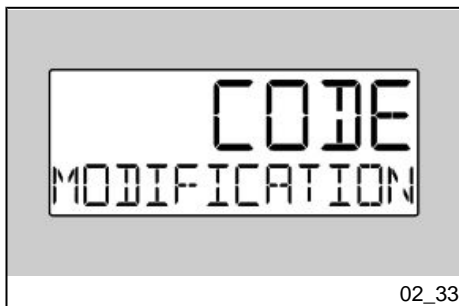

02_33

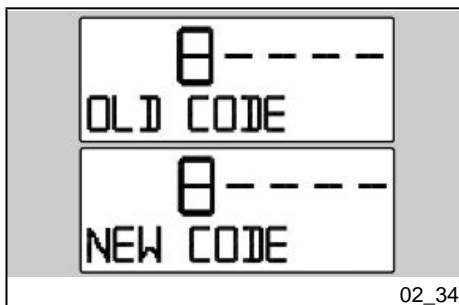

02_34

User Code Recovery "Recover user code"

This function must be used should it be necessary to change the user code when the user no longer remembers the current code. Both keys stored in the vehicle memory are needed to access this function.

Press and hold the "MODE" to activate the function. The message "INSERT KEY 1" is shown on the display, requesting identification of the first key. Insert the key. If the correct key is recognised within twenty seconds, the message "INSERT KEY 2" is shown on the display. Insert the second key. If the second key is also recognised within twenty seconds, the instrument panel resets the user code to the default code (five zeros - 00000). Enter the new user code following the "SET CODE MODIFICATION" procedure.

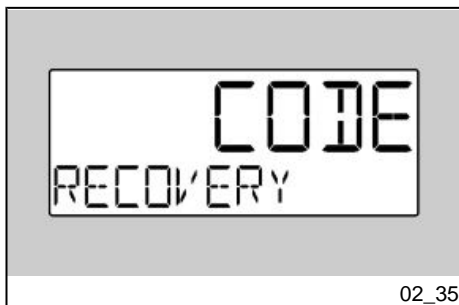

02_35

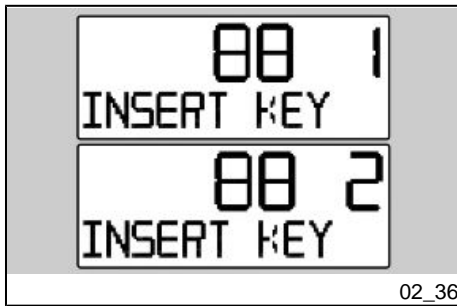

02_36

Select unit (Km/mi) "Change odometer unit of measurement"

From this mode, press the "MODE" selector up or down briefly to toggle the unit of measurement used between Km and miles. The modified selection is effective on all instrument panel functions using these units of measurement.

Select unit (L/100 - Km/L - US mpg - IMP mpg) "Change consumption indicator unit of measurement"

From this mode, press the "MODE" selector up or down briefly to toggle the unit of measurement used between L/100 Km, Km/L, US mpg and IMP mpg. The modified selection is effective on all instrument panel functions using these units of measurement.

Set unit °C - °F "Change thermometer unit of measurement"

This function is used to select the unit of measurement for ambient temperature. From this mode, press the "MODE" selector up or down briefly to toggle between the two units of measurement available:

- °C

- °F

Press and hold the "MODE" selector to save the setting. The instrument panel returns to the "ODOMETER" screen.

CAUTION



FOR THE SAFETY OF THE RIDER AND PASSENGER, THESE PROCEDURES ARE ONLY POSSIBLE WITH THE VEHICLE AT A STANDSTILL.

Ignition switch

NOTE

KEEP THE SPARE KEY IN DIFFERENT PLACE, NOT WITH THE VEHICLE.

The ignition switch is located on the headstock upper plate.

The vehicle is supplied with two keys (one is the spare key).

The lights can only be switched off with the ignition switch turned to **OFF**.

NOTE

THE KEY OPERATES THE IGNITION SWITCH/STEERING LOCK AND THE SADDLE LOCK.

NOTE

THE LIGHTS COME ON AUTOMATICALLY AFTER THE ENGINE STARTS.

Locking the steering wheel (02_37)



TO AVOID LOSING CONTROL OF THE VEHICLE, NEVER TURN THE KEY TO "LOCK" WHILE RIDING.

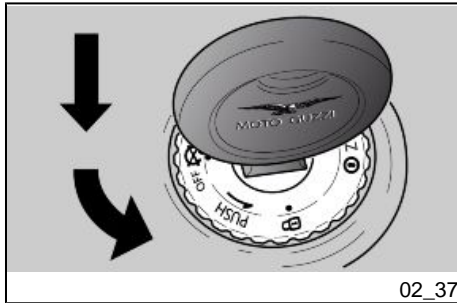

To lock the steering:

- Turn the handlebar fully to the left.
- Turn the key to «OFF».
- Push in the key and turn it anticlockwise (to the left), steer the handlebar slowly until the key is set to «LOCK».
- Extract the key.

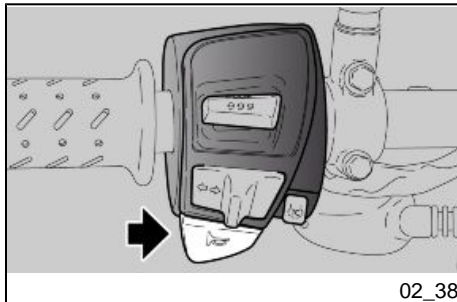

Horn button (02_38)

Press it to activate the horn.

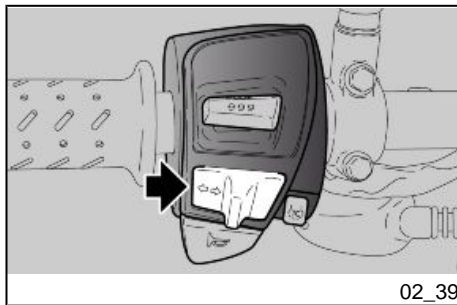

Switch direction indicators (02_39)

Move the switch to the left, to indicate a left turn; move the switch to the right to indicate a right turn. Pressing the switch deactivates the turn indicator.

CAUTION

IF THE WARNING LIGHT WITH ARROWS FLASHES QUICKLY, IT MEANS THAT ONE OR BOTH TURN SIGNALS LIGHT BULBS ARE BURNT OUT.

The turn indicators have a self-cancelling function that implements the following logic.

With the vehicle at standstill (speed = zero), the turn indicators continue flashing indefinitely.

With the vehicle in motion, the turn signals self-cancel when one of the two following conditions is met:

- After a time (t) = 40 sec.
- After riding 500 m (0.31 mi)

If the vehicle speed reaches zero during this period, the time and distance counts are reset and start again from zero when the vehicle starts moving once again.

Switching on the opposite side turn indicators without pressing the switch in the intermediate reset position causes both the time and distance counters to reset and recommence from zero.

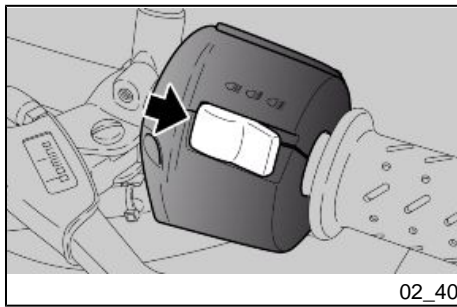

High/low beam selector (02_40)

- the switch in the central position keeps the daylight running lights, the instrument panel lights and the low beam on.
- In the left hand position the high beam is activated.
- In the right hand position the high beam flashes in case of danger or emergency.

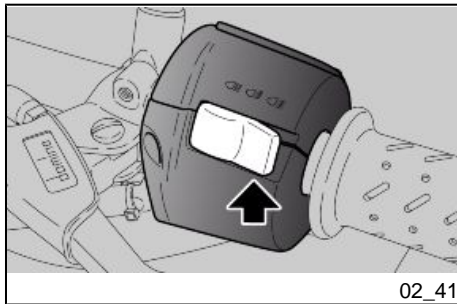

Passing button (02_41)

Uses the high beam flash in case of danger or emergency.

Releasing the switch deactivates the high beam flash.

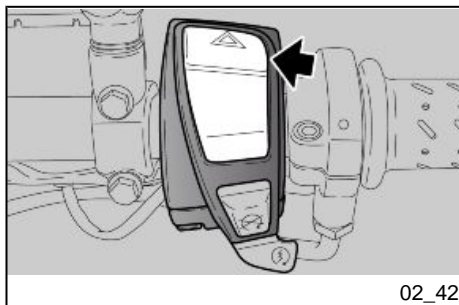

Flasher button (02_42)

The HAZARD system is only available at key ON. By pressing the button, the four turn indicators and their warning lights on the panel are turned on at the same time. Pressing again deactivates the system. The HAZARD light remains on even after extracting key but it cannot be deactivated.

If the key is switched to the OFF position, upon restarting the function will be deactivated.

CAUTION

IF A TURN INDICATOR IS SWITCHED ON WHILE THE HAZARD SYSTEM IS ACTIVE, THE HAZARD SYSTEM IS DISABLED TEMPORARILY UNTIL THE TURN INDICATOR IS RESET.

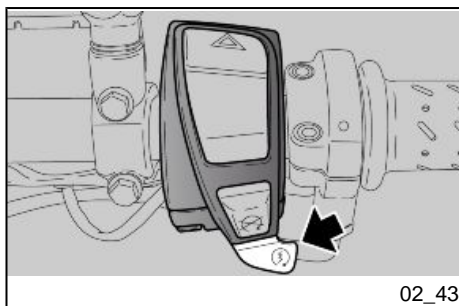

Start-up button (02_43)

- Press the button and the starter motor spins the engine.



THE ENGINE CAN BE STARTED WITH RELEASED OR JUST TURNED THROTTLE CONTROL.

Engine stop switch (02_44)

CAUTION



DO NOT OPERATE THE ENGINE STOP SWITCH WHILE RIDING THE VEHICLE.

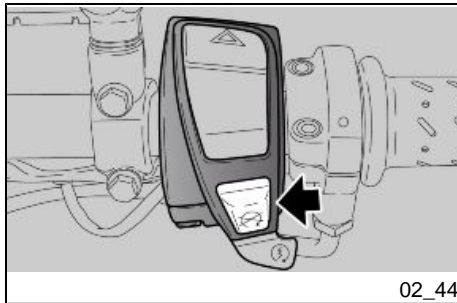

It acts as a safety or emergency switch.

Press this switch to stop the engine.

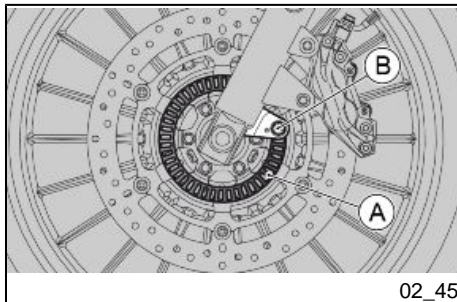

System ABS (02_45, 02_46, 02_47)

The vehicle is equipped with a locking ABS system on the front and rear wheel.

A: Tone wheel

B: Speed sensor

- **ABS:** It is a hydraulic - electronic device that limits the pressure within the braking circuit when a sensor, located on the wheels, detects its tendency to lock. This system prevents the wheels from locking and reduces the risk of falling.

In case of failure of the ABS system, immediately reported to the rider with ABS warning light on the instrument panel, the vehicle retains the characteristics of a conventional braking system. In case of ABS warning light, reduce speed and go to an

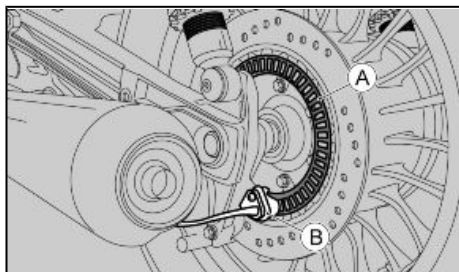

02_46

Authorised Service Centre for the appropriate checks. The safety provided by the ABS does not, in any case, justify risky manoeuvres. The stopping distance may be greater, compared to a conventional vehicle equipped with traditional braking in the following conditions:

- Riding on rough roads, with gravel or snow
- Riding on roads with holes or bumps

It is therefore recommended to reduce speed in these conditions.

CAUTION



AT VERY LOW SPEEDS (LESS THAN 5 km/h (3.11 miles)) THE ABS SYSTEM IS DISABLED.

IT IS THEREFORE RECOMMENDED TO PAY ATTENTION IN CASES OF BRAKING IN LOW GRIP CONDITIONS AT LOW SPEED (FOR EXAMPLE BRAKING ON GARAGE FLOOR TILES AFTER HAVING RIDDEN ON WET ROADS OR SIMILAR SITUATIONS).

NOTE

WHEN TURNING THE KEY ON, THE ABS WARNING LIGHT TURNS ON AND FLASHES UNTIL REACHING 5 km/h (3.11 mph); AT THIS POINT IT TURNS OFF.

CAUTION



THE STEADY LIGHTING OR THE CONTINUOUS FLASHING OF THE ABS WARNING LIGHT INDICATES THE PRESENCE OF AN ANOMALY AND THE DEACTIVATION OF THE ABS FUNCTIONALITY.

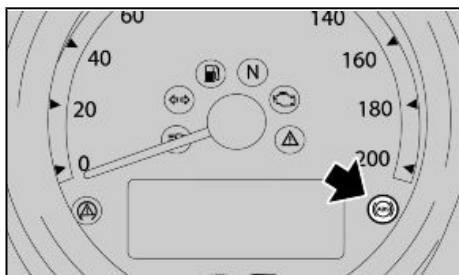

02_47

CAUTION



IN THE EVENT OF MALFUNCTION OF THE BATTERY, THE ABS - MGCT SYSTEM TURNS OFF.

Characteristic

Distance between tone wheel and front sensor

0.3 - 2.00 mm (0.012 - 0.079 in)

Distance between tone wheel and rear sensor

0.3 - 2.00 mm (0.012 - 0.079 in)

MGTC system(Moto Guzzi Controllo Trazione) (02_48, 02_49, 02_50)

The MGCT system is a device that helps the rider during acceleration in manoeuvres with the aim to increase the stability of the vehicle, especially on slippery surfaces or in conditions that can cause sudden slippage of the rear wheel. In these situations, the MGCT automatically intervenes by reducing engine output within the limit imposed by the grip conditions, contributing significantly to the maintenance of stability of the vehicle. The rider is entirely responsible for riding at an appropriate speed in relation to the weather, road conditions, vehicle load and state of the tyres, and allowing for an adequate margin of safety, taking into consideration that the physical limits of vehicle grip on the road never have to be exceeded. Under no circumstances can MGCT compensate for any rider error or improper use of the throttle.

CAUTION

THE MGCT SYSTEM DOES NOT PREVENT FALLING IN TURNS.

ACCELERATING SUDDENLY WHILE THE VEHICLE IS INCLINED OR WITH THE HANDLEBARS TURNED WILL PUT THE VEHICLE IN AN UNSTABLE STATE THAT IS EXTREMELY DIFFICULT TO RECTIFY.

DO NOT SPEED RECKLESSLY. LIMITS OF GRIP ARE DETERMINED BY LAWS OF PHYSICS, WHICH EVEN THE MGCT SYSTEM CANNOT OVERCOME.

WARNING

THE MGCT SYSTEM IS BASED ON THE RECOGNITION OF SPEED DIFFERENCES BETWEEN FRONT AND REAR WHEEL. FOR THE SYSTEM TO PERFORM CORRECTLY IN ALL CONDITIONS, THE PROCEDURE MUST BE PERFORMED EACH TIME A TYRE IS REPLACED - EVEN IF ONLY ONE OF THE TYRES.

FOR THE CALIBRATION OF THE CONTROL UNIT PERFORM THE PROCEDURE BELOW.

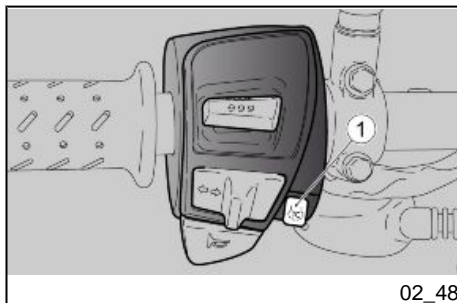

- **BUTTON (1) (with the engine running):** press and hold to activate / deactivate, press briefly to toggle between levels 1 and 2.
- **ICON (2):** operating indication icon.

Flashing mode:

- Off with the vehicle in gear: the system is working, but is not active (normal condition).
- Flashing quickly with moving vehicle: the system is up and running (conditions of low grip and intervention to reduce engine power); we recommend the utmost caution because the grip limit has been exceeded; restore the vehicle safety conditions by gently reducing the throttle opening.
- Lit with moving vehicle: the system is disabled and will not intervene in case of loss of grip.

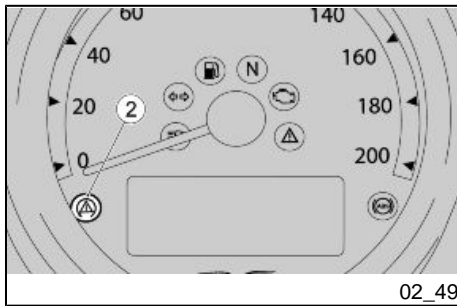

- @@ If the system was disabled deliberately by the user (by pressing and holding the on/off button (1) with the engine running), it is highly advisable to reactivate the system as soon as possible.
- If the deactivation was NOT voluntary, there is an MGCT failure: in this case you must contact an Authorised Service Centre for the diagnosis and the reactivation of the system.

To ensure maximum safety of the vehicle it is advisable to keep the system active. Deactivation may be necessary only in case of starting with very low grip surfaces (mud, snow) on which the operation of the MGCT could actually prevent the movement of the vehicle.

Description of MGCT levels

The MGCT offers the user a choice of two levels (1 and 2):

- "1" Suitable for normal use with normal grip conditions. The response of the system is less invasive than in level "2".

- "2" Suitable for poor grip conditions, such as riding on wet roads or on slippery or particularly dirty tarmac. The response of the system is more invasive than in level "1".

NOTE

AT VEHICLE START-UP THE MGCT WARNING LIGHT FLASHES AT THE SAME FREQUENCY AS THE ABS WARNING LIGHT, INDICATING A DIAGNOSTIC PHASE OF THE SYSTEM. IN THE ABSENCE OF ERRORS, BOTH WARNING LIGHTS TURN OFF AT THE SAME TIME WHEN EXCEEDING 5 km/h (3.11 mph).

IN CASE OF ABSENCE OF FLASHING AT START-UP, THE SYSTEM MAY NOT WORKING, PLEASE CONTACT AN AUTHORISED SERVICE CENTRE.

WARNING



AT EACH KEY-ON, THE MGCT SYSTEM IS RE-ACTIVATED AT THE LAST LEVEL SET.

IF DISABLED BY THE USER, THE MGCT SYSTEM KEEPS THE STATE OF IN-ACTIVITY ONLY IF THE VEHICLE IS OFF, BY USING THE ENGINE STOP

SWITCH; AT THE NEXT KEY ON, THE MGCT SYSTEM IS ENABLED AUTOMATICALLY AT THE LEVEL SET BEFORE IT WAS DEACTIVATED.

CAUTION



IT IS EMPHASISED THAT THE RIDING AUXILIARY SYSTEM CAN NOT CHANGE THE PHYSICAL LIMITS OF GRIP AND IS NOT A SUBSTITUTE FOR PROPER MANAGEMENT OF POWER, BOTH ON STRAIGHT STRETCHES AND IN TURNS. THEREFORE, IT IS RECOMMENDED TO ALWAYS USE THE VEHICLE WITH THE UTMOST CARE AND IN ACCORDANCE WITH THE REGULATIONS IN FORCE.

NOTE

IN CASE OF ROADS FULL OF POTHoles BRIEF ACTIVATION OF THE MGCT SYSTEM MAY OCCUR. THIS OCCURS UNDER NORMAL OPERATING CONDITIONS OF THE VEHICLE.

CAUTION



A POOR STATE OF MAINTENANCE OF THE TYRES CAN RESULT IN ABNORMAL OPERATION OF THE MGCT SYSTEM.

IN CASE OF REPEATED INTERVENTIONS OF THE MGCT, EVEN ON ROAD SURFACES WITH GOOD GRIP OR SMALL THROTTLE OPENINGS, IT IS NECESSARY TO CHECK FOR WEAR AND/OR THE STATE OF INFLATION OF TYRES FIRST. IF THE PROBLEM PERSISTS, CONTACT AN AUTHORISED SERVICE CENTRE.

CAUTION



IN THE EVENT OF MALFUNCTION OF THE BATTERY, THE ABS - MGCT SYSTEM TURNS OFF.

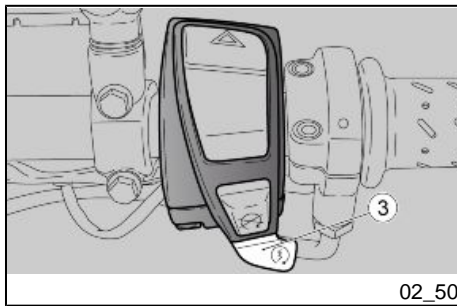

MGCT SYSTEM CALIBRATION PROCEDURE

In order to maintain the effectiveness of the MGCT system following the replacement of one or both tyres or in the case of serious wear, causing a non-compliant behaviour of the MGCT, a calibration procedure of the system must be performed as follows on a straight flat stretch of road.

Check that the tyres are inflated to the correct pressure before calibrating the MGCT system.

- Allow the engine to idle for at least 5 seconds.
- Check that the MGCT is activated at level 1 or 2. Otherwise, activate it.
- Pull the clutch lever while pressing the starter button (3) for at least 5 seconds. The activation of the process will be confirmed by the MGCT warning light (2) turning on with fast flashing.
- Accelerate to a constant speed of 30 km/h (18.64 mph) in second gear, and maintain this speed for at least 8 seconds.
- The end of the procedure will be indicated by the MGCT warning light (2) turning off. The MGCT system is active.
- Once the procedure is completed, it is necessary to switch the ignition key to (OFF) and wait for at least 60 seconds before being able to switch again to (ON).
- In case of failure to complete the procedure within 2 minutes, the MGCT warning light (2) will stay on steady and the MGCT system will remain off until switching to (OFF).
- To reactivate the MGCT system, it must be switched again to (ON). It is however necessary to repeat the process until it succeeds.

CAUTION

IF NECESSARY, CONTACT AN AUTHORISED SERVICE CENTRE.

Characteristic

Distance between tone wheel and front sensor

0.3 - 2.00 mm (0.012 - 0.079 in)

Distance between tone wheel and rear sensor

0.3 - 2.00 mm (0.012 - 0.079 in)

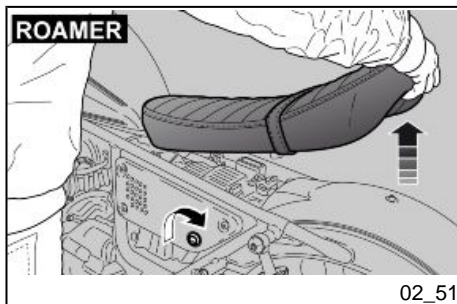
Opening the saddle (02_51, 02_52)

- Rest the vehicle on its stand.
- Insert the key in the saddle lock.
- Turn the key clockwise by pressing slightly the centre of the saddle rear part so that the hook is easily released; lift and slide off the saddle backwards.

CAUTION

BEFORE LOWERING AND LOCKING THE SADDLE, MAKE SURE THAT THE KEY HAS NOT BEEN LEFT INSIDE THE GLOVE BOX.

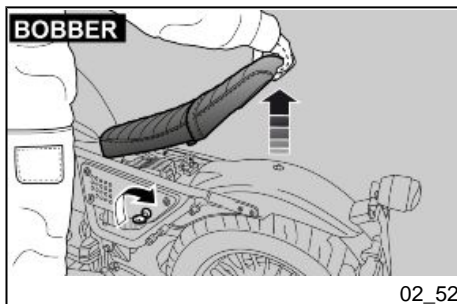
**To lock the saddle:**

- Place the saddle front part in its seat and lower the rear part.
- Press the rear part to trip the lock.



BEFORE RIDING, MAKE SURE THAT THE SADDLE IS CORRECTLY LOCKED.

USB Port

At the right side of the motorcycle, near the steering column, is a USB plug.

To use it, remove the protection cap.



TO AVOID THAT WATER AND/OR HUMIDITY CAN DAMAGE THE USB PLUG, DO NOT CONNECT ANY DEVICES IN CASE OF RAIN.



THE SUPPLIED USB SOCKET IS COMPATIBLE WITH THE DEVICES OF THE FOLLOWING BRANDS: Apple iPhone, Apple iPod, Apple iPod Nano, Apple iPod Touch, Blackberry Pearl, Blackberry 8xxx IS NOT COMPATIBLE WITH THE DEVICES FOR THE PRODUCTS OF MOTOROLA.



IF A USB DEVICE IS CONNECTED, ENSURE THE CORRECT POSITIONING OF THE CABLE TO AVOID THAT IT WILL BE SMASHED.

The USB socket is active once the key is turned to «ON».

WARNING

PROLONGED USE OF THE PLUG SOCKET MAY RESULT IN PARTIAL DISCHARGE OF THE BATTERY.

USB PORT

Output voltage	(5.00+/-0.25) DC
Charging current	1A Max

Identification (02_53, 02_54)

Write down the chassis and engine number in the specific space in this booklet. The chassis number is handy when purchasing spare parts.

CAUTION



THE MODIFICATION OF THE IDENTIFICATION CODES IS A SERIOUS PUNISHABLE CRIME. HOWEVER, THE LIMITED WARRANTY FOR NEW VEHICLES WILL BE VOID IF THE VEHICLE IDENTIFICATION NUMBER (VIN) HAS BEEN MODIFIED OR NOT PROMPTLY DETERMINED.

CHASSIS NUMBER

The frame number is stamped on the right hand side of the headstock.

Chassis No.

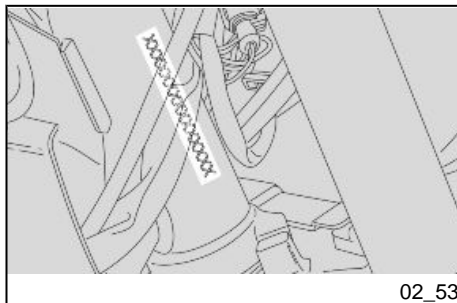

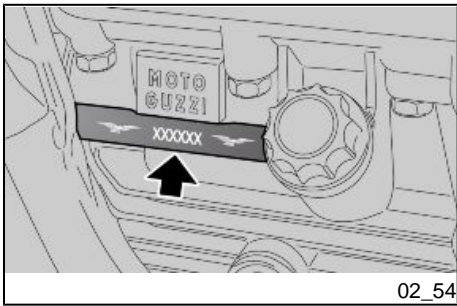

02_54

ENGINE NUMBER

The engine number is stamped on the left side, close to the engine oil level check cap.

Engine No.

V9 Roamer - V9 Bobber



Chap. 03
Use

Checks (03_01)

CAUTION

BEFORE SETTING-OFF, ALWAYS CARRY OUT A PRELIMINARY CHECK OF THE VEHICLE, FOR CORRECT AND SAFE OPERATION. FAILURE TO DO SO MAY LEAD TO SEVERE PERSONAL INJURY OR VEHICLE DAMAGE. DO NOT HESITATE TO CONTACT AN Official Moto Guzzi Dealer IF YOU DO NOT UNDERSTAND HOW SOME CONTROLS WORK OR IF MALFUNCTIONING IS DETECTED OR SUSPECTED. CHECKS DO NOT TAKE LONG AND RESULT IN SIGNIFICANTLY ENHANCED SAFETY.

This vehicle has been programmed to indicate in real time any operation failure stored in the electronic control unit memory.

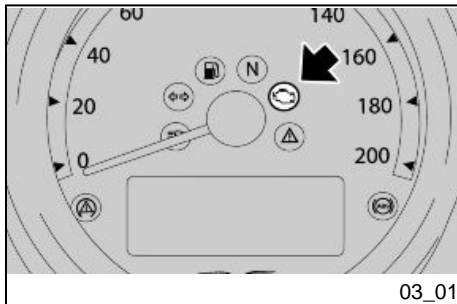

Every time the ignition switch is set to 'KEY ON', the 'MI' warning light turns on for about two seconds.

PRE-RIDE CHECKS

Front and rear disc brake

Check for proper operation. Check brake lever empty travel and brake fluid level. Check for leaks. Check

	brake pads for wear. If necessary top-up with brake fluid.
Throttle grip	Check that the throttle functions smoothly and can be fully opened and closed in all steering positions. Adjust and/or lubricate if necessary.
Engine oil	Check and/or top-up as required.
Wheels/ tyres	<p>Check that tyres are in good conditions. Check inflation pressure, tyre wear and potential damage.</p> <p>Remove any possible strange body that might be stuck in the tread design.</p>
Brake levers	<p>Check they function smoothly.</p> <p>Lubricate the joints and adjust the travel if necessary.</p>
Clutch lever	Check correct operation and empty travel. Check the condition of the cable on the handlebar and on the engine. The cable must be replaced if it shows any signs of fraying. Lubricate the joints if necessary.
Steering	Check that the rotation is uniform, smooth and there are no signs of clearance or slackness.

Side stand	Check that it slides smoothly and that it snaps back to its rest position upon spring tension. Lubricate couplings and joints if necessary.
Clamping elements	Check that the clamping elements are not loose. Adjust or tighten them as required.
Fuel tank	Check the coolant level and refill if necessary. Check the circuit for leaks or obstructions. Check that the tank cap closes correctly.
Engine stop switch (ON - OFF)	Check function.
Lights, warning lights, horn, rear stop light switch and electrical devices	Check function of horn and lights. Replace bulbs or repair any faults noted.
Transmission oil - Guzzi	Check. Should top-up be necessary, please refer to an authorised Moto Guzzi repair shop.
Tone wheels	Check that the tone wheels are perfectly clean and in good conditions.

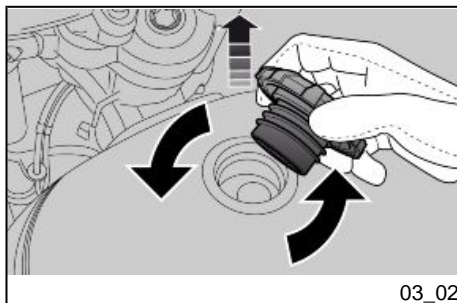

03_02

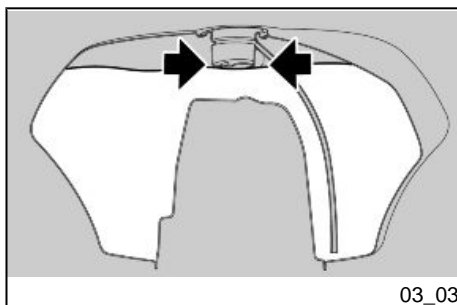

03_03

Refuelling (03_02, 03_03)

To refuel:

- Turn the cap anticlockwise and remove

CAUTION



ALWAYS USE PETROL WITH A MAXIMUM OF 10% BIOETHANOL CONTENT (E10).

DO NOT USE PETROL WITH AN ETHANOL CONTENT HIGHER THAN 10%; THIS USE COULD DAMAGE THE FUEL SYSTEM COMPONENTS AND/OR COMPROMISE ENGINE PERFORMANCE.

DO NOT ADD ADDITIVES OR ANY OTHER SUBSTANCES TO THE FUEL.

WHEN USING A FUNNEL OR ANY OTHER ELEMENT, MAKE SURE IT IS PERFECTLY CLEAN.



WHEN FILLING THE TANK COMPLETELY, DO NOT FILL BEYOND THE LOWER EDGE OF THE RECESS (SEE FIGURE).

WHEN REFUELLING, AVOID FUEL LEAKS THAT MAY CAUSE DAMAGES TO PROPERTIES AND/OR PEOPLE AND FIRE HAZARD.

DURING REFUELLING, AVOID THE USE OF ELECTRIC DEVICES AND/OR MOBILE PHONES, BECAUSE FUEL VAPOURS MAY CAUSE DAMAGE TO OBJECTS AND/OR PERSONAL INJURIES.

Characteristic

Fuel tank (including reserve) V9 Roamer

15±0.5 l (3.30±0.11 UK gal; 3.96±0.13 US gal)

Fuel tank (including reserve) V9 Bobber

15±0.5 l (3.30±0.11 UK gal; 3.96±0.13 US gal)

Fuel tank reserve

4±0.5 l (0.88±0.11 UK gal; 1.06±0.13 US gal)

- Refuel.

After refuelling:

CAUTION

THE TANK MUST ALWAYS BE CLOSED CORRECTLY BY TIGHTENING THE CAP CLOCKWISE UNTIL IT LOCKS INTO PLACE.

MAKE SURE THE CAP IS TIGHTLY CLOSED.

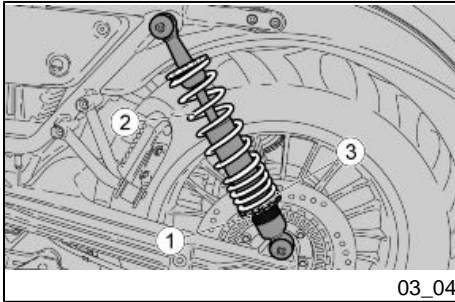

Rear shock absorbers adjustment (03_04, 03_05)

The shock absorber has an adjuster ring (1) for setting spring preload (2) and a locking ring nut (3).

NOTE

IT IS POSSIBLE TO VARY THE PRELOAD OF THE SHOCK ABSORBERS DEPENDING ON THE LOAD ON THE VEHICLE (PASSENGER OR HEAVY LOAD).

NOTE

CARRY OUT MAINTENANCE OPERATIONS AT HALF THE INTERVALS SPECIFIED IF THE VEHICLE IS USED IN PARTICULAR RAINY OR DUSTY CONDITIONS, OFF ROAD OR FOR TRACK USE.

CAUTION

TO PREVENT DAMAGE TO THE ADJUSTER SCREWS (1), NEVER FORCE THEM BEYOND THE END OF TRAVEL IN EITHER DIRECTION.

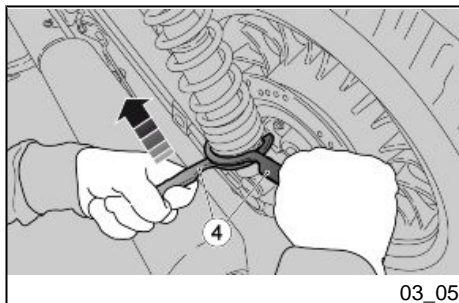

- Using two hook spanners (4), keep the preload adjustment ring nut (1) fastened and unscrew the locking nut (3) as indicated in the image.
- Use the adjustment ring nut (1) to adjust the spring preloading for the shock absorber (2).
- Screw to increase preloading; and vice versa, screw to reduce it.
- Once the adjustment is completed, tighten the ring nut (3) using two hook spanners.

CAUTION

FOR PROPER VEHICLE STABILITY IT IS ALWAYS A GOOD IDEA TO MAKE SURE THAT BOTH SHOCK ABSORBERS ARE SET TO THE SAME POSITION. IF NECESSARY, CONTACT AN Official Moto Guzzi Dealership.

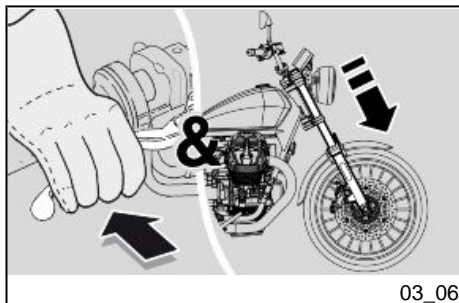
**Front fork adjustment (03_06)**

Carry out the following checks regularly:

Operating the front brake lever, press the handlebar repeatedly to send the fork fully down. The shock absorber should compress and extend smoothly with no signs of oil leakage on the stanchions.

Check the tightening of all the elements and the correct operation of the front and rear suspension joints.

CAUTION

TO HAVE THE FRONT FORK OIL AND OIL SEALS REPLACED, CONTACT AN Official Moto Guzzi Dealer.

Clutch lever adjustment (03_07, 03_08)

Adjustment clutch when the engine stops or the vehicle tends to move forward even when clutch lever is operated and the gear engaged, or if the clutch "slides", resulting in acceleration delay considering the engine revs.

- In order to maintain a correct tension and an optimal clutch operation, it is necessary to check and if necessary provide tension to the cable:
- Urban use every 1,000 km (621.37 mi)
- Extra urban use every 5,000 km (3,106.86 mi)
- In any case, every time the detachment of the clutch before the standard factory setting is indicated.

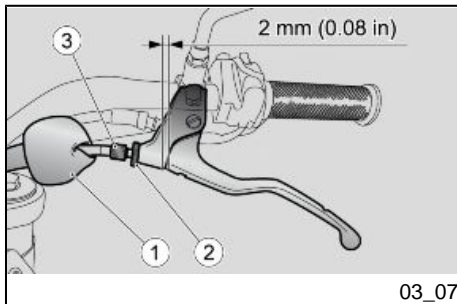

To perform the adjustment, follow the indicated points:

1. Remove the protection casing (1)
2. Loosen the ring nut (2)
3. Turn the set screw (3) with straight handlebar until the empty travel corresponding to the fixed abutment on the handlebar is 2 mm (0.08 in)

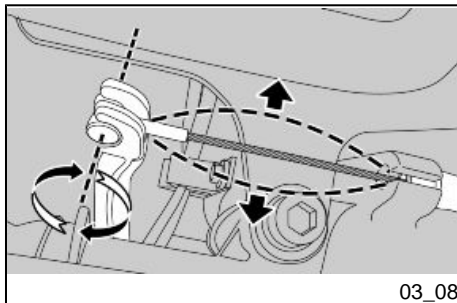

4. Push the clutch control lever placed on the gearbox towards the rear wheel
5. Pull the clutch control lever placed on the gearbox towards the opposite side (as in point 4) checking that the cable is not tightened.
6. During the previous operation, check that the cable lug turns freely around its axis, regarding the clutch lever
7. Tighten the ring nut (2) holding the adjuster (3)

8. Refit the protection casing (1)

9. If after the adjustment in point 3 it is not possible to ascertain the condition of "point 6", contact an Authorised Moto Guzzi Dealer to verify the proper operation of the clutch control.

10. If the adjuster stroke (3) is not sufficient to ensure the required clearance, contact an Authorised Moto Guzzi Dealer

Running in

Running in is essential to ensure the durability of the vehicle. During the first 1,500 Km (932.06 mi), observe the following rules to ensure the reliability and performance of the vehicle throughout its lifetime:

- Avoid full throttle starts and hard acceleration;
- Avoid exceeding 4500 rpm;
- Avoid hard or prolonged braking;
- Do not ride for prolonged periods at sustained high speed; preferably ride the motorcycle on varied routes with frequent, gentle acceleration and deceleration;
- Ride prudently to gradually gain familiarity with the motorcycle, testing progressively higher throttle apertures only as you gain confidence

CAUTION

THIS VEHICLE IS EQUIPPED WITH A SINGLE DISC DRY CLUTCH. IN CERTAIN CONDITIONS, THE CLUTCH MAY EMIT A SLIGHT AND DISTINCTIVE ODOUR OF CLUTCH MATERIAL. THIS IS NORMAL AND IS NOT INDICATIVE OF A FAULT.

CAUTION

THE FULL PERFORMANCE OF THE VEHICLE IS ONLY AVAILABLE AFTER THE SERVICE AT THE END OF THE RUNNING IN PERIOD.



TO PREVENT THE RISK OF INJURY TO YOURSELF OR OTHERS AND/OR DAMAGE TO THE VEHICLE, TAKE THE YOUR MOTORCYCLE TO AN AUTHORISED Moto Guzzi DEALER AT THE SPECIFIED MILEAGE INTERVALS TO HAVE THE CHECKS LISTED IN THE MAINTENANCE SCHEDULE TABLE CARRIED OUT.

Moving off / riding

CAUTION

THE ECU INSTALLED ON THIS MOTORCYCLE COMPENSATES FOR INCREASED ELECTRIC POWER CONSUMPTION BY TEMPORARILY RAISING THE IDLE SPEED; VARIATIONS IN ENGINE SPEED WITHIN THIS RANGE ARE THEREFORE NORMAL.

CAUTION

IF THE FUEL RESERVE WARNING LAMP ILLUMINATES WHILE RIDING, THIS INDICATES THAT THE FUEL LEVEL IS LOW AND ONLY LIMITED RANGE IS REMAINING.

REFUEL AS SOON AS POSSIBLE.

WARNING

IF THE MOTORCYCLE TURNS OFF ACCIDENTALLY THE ECU ALLOWS A RESTART WITHIN THE NEXT 5 SECONDS. ONCE THIS PERIOD OF TIME HAS PASSED THE ECU WILL PREVENT STARTING FOR ANOTHER 3 SECONDS AND ONLY THEN WILL IT BE POSSIBLE TO START THE MOTORCYCLE.

Parking

It is very important to select an adequate parking spot, in compliance with road signals and the guidelines described below.

CAUTION

PARK ON SAFE AND LEVEL GROUND TO PREVENT THE MOTORCYCLE FROM FALLING.

DO NOT LEAN THE VEHICLE AGAINST A WALL OR LAY IT ON THE GROUND.

ENSURE THAT THE VEHICLE AND, IN PARTICULAR, PARTS OF THE VEHICLE WHICH MAY BECOME HOT (ENGINE, EXHAUST SYSTEM, BRAKE DISCS) ARE NOT A HAZARD TO PERSONS OR CHILDREN. DO NOT LEAVE YOUR VEHICLE UNATTENDED WITH THE ENGINE ON OR THE KEY IN THE IGNITION SWITCH.

CAUTION

IF THE VEHICLE FALLS OR IS ON A STEEP INCLINE FUEL CAN LEAK.

FUEL USED TO DRIVE INTERNAL COMBUSTION ENGINES IS HIGHLY FLAMMABLE AND CAN BECOME EXPLOSIVE UNDER CERTAIN CONDITIONS.



DO NOT REST THE RIDER OR PASSENGER WEIGHT ON THE SIDE STAND.

Catalytic silencer

The vehicle has silencers with a "platinum - palladium - rhodium three-way" metal catalytic converter.

This device oxidises the CO (carbon monoxide) producing carbon dioxide, and the UHC (unburned hydrocarbons) producing water vapour and reduces NOx (nitrogen oxide) producing oxygen and nitrogen present in the exhaust fumes.



DO NOT PARK THE VEHICLE NEAR DRY BRUSHWOOD OR IN PLACES EASILY ACCESSIBLE BY CHILDREN BECAUSE THE CATALYTIC CONVERTER REACHES HIGH TEMPERATURES DURING VEHICLE OPERATION; FOR THIS REASON, PAY UTMOST ATTENTION AND DO NOT TOUCH IT UNTIL IT HAS COMPLETELY COOLED DOWN.



DO NOT USE LEADED PETROL AS IT CAUSES IRREPARABLE DAMAGE TO THE CATALYTIC CONVERTER.

Vehicle owners are warned that the law may prohibit the following:

- the removal of any device or element belonging to a new vehicle or any other action by anyone leading to render it non-operating, if not for maintenance, repair or replacement reasons, in order to control noise emission before the sale or delivery of the vehicle to the ultimate buyer or while it is used;
- using the vehicle after that device or element has been removed or rendered non-operating.

Check the exhaust silencer and the silencer pipes, ensuring there are no signs of penetrative corrosion and that the exhaust system works properly.

If the noise produced by the exhaust system increases, get immediately in touch with the Dealer or with a Moto Guzzi authorised repair shop.

NOTE

DO NOT TAMPER WITH THE EXHAUST SYSTEM.

Stand (03_09, 03_10, 03_11)

BEFORE SETTING OFF, MAKE SURE THE STAND HAS BEEN COMPLETELY RETRACTED TO ITS POSITION.

DO NOT REST THE RIDER OR PASSENGER WEIGHT ON THE SIDE STAND.

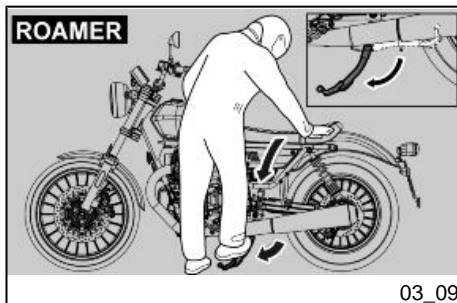

THE SIDE STAND MUST ROTATE FREELY. IF NECESSARY GREASE THE JOINT.

**SIDE STAND**

If the stand has been folded up for any manoeuvre (for example, when the vehicle is in motion), place the vehicle on the stand again as follows:

- Grasp the left grip and put the right hand on the upper rear part of the vehicle.
- Push the side stand with your right foot to fully extend the stand.
- Lean the vehicle until the stand touches the ground.
- Turn the handlebar fully leftwards.

CAUTION

MAKE SURE THE VEHICLE IS STABLE.

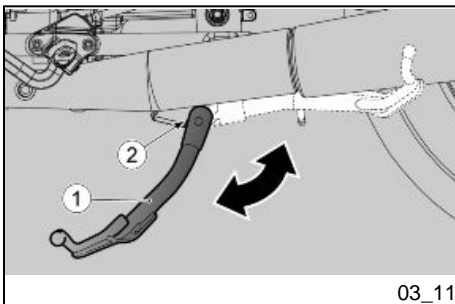
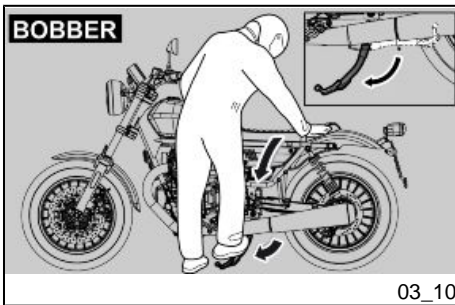

A safety switch (2) is installed on the side stand (1) to inhibit ignition or to stop the engine when a gear is engaged and the side stand (1) is lowered.

Suggestion to prevent theft

CAUTION

WHEN USING A DISC LOCKING DEVICE, PAY UTMOST ATTENTION TO REMOVE IT BEFORE RIDING. FAILURE TO OBSERVE THIS WARNING MAY CAUSE SERIOUS DAMAGE TO THE BRAKING SYSTEM AND ACCIDENTS WITH CONSEQUENT PHYSICAL INJURIES OR EVEN DEATH.

NEVER leave the ignition key in the lock and always use the steering lock. Park the vehicle in a safe place such as a garage or a place with guards. Whenever possible, use an additional anti-theft device. Make sure all vehicle documents are in order and the road tax paid. Write down your personal details and telephone number on this page to help identifying the owner in case of vehicle retrieval after a theft.

LAST NAME:

NAME:

ADDRESS:

TELEPHONE NO.:

WARNING

IN MANY CASES, STOLEN VEHICLES CAN BE IDENTIFIED BY DATA IN THE USE / MAINTENANCE BOOKLET.

Safe driving

Some simple tips are provided below that will enable you to use your motorcycle on a daily basis in greater safety and peace of mind. Your skill and your mechanical knowledge are the basis of a safe ride. We recommend trying out the motorcycle in traffic-free zones to familiarise with it.

1. Before riding off, remember to put the helmet on and fasten it correctly.
2. Reduce speed on rough roads and ride with care.
3. After riding on a long stretch of wet road without using the brakes, braking can be poor at the beginning. In these conditions, it is a good idea to apply the brakes from time to time.
4. Although the vehicle is equipped with an ABS system, pay attention when braking on wet surfaces, on dirt or on a slippery road surface.
5. Avoid riding off by mounting the scooter when it is resting on its support.

6. If the motorcycle is used on roads covered with sand, mud, snow mixed with salt, etc., clean the brake discs frequently with a mild detergent in order to prevent abrasive particles from building up inside the holes, which can result in early brake pads wear.

CAUTION

ALWAYS RIDE WITHIN YOUR LIMITS. RIDING UNDER THE INFLUENCE OF ALCOHOL OR OTHER DRUGS AND CERTAIN MEDICINES IS EXTREMELY DANGEROUS.

CAUTION

ANY ELABORATION THAT MODIFIES THE VEHICLE'S PERFORMANCES, SUCH AS TAMPERING WITH ORIGINAL STRUCTURAL PARTS IS STRICTLY FORBIDDEN BY LAW, AND RENDERS THE MOTORCYCLE NO LONGER CONFORMING TO THE APPROVED TYPE AND DANGEROUS FOR RIDING.

CAUTION

DO NOT ADJUST THE MIRRORS WHILE RIDING. THIS COULD CAUSE YOU TO LOOSE CONTROL OF THE MOTORCYCLE.

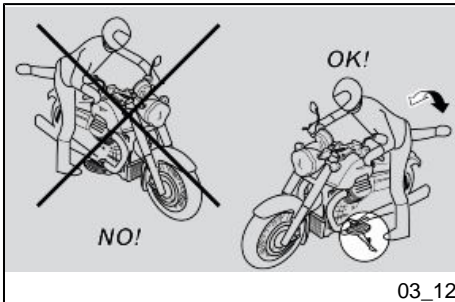

Basic safety rules (03_12, 03_13, 03_14, 03_15, 03_16)

The following recommendations should receive your maximum attention, because they are provided to increase your safety, and decrease damage to people, things and vehicles, in the case of a fall of the rider or passenger from the vehicle and/or from the fall or overturning of the vehicle.

Mounting and dismounting the vehicle should always be performed with total freedom of movement and with the hands free of all objects. (i.e.- objects, helmet, gloves, or glasses).

Mount and dismount only on the left side of the vehicle, and only with the side stand lowered.

The stand is designed to support the weight of the vehicle and a small additional weight, which does not include the rider and passenger.

Mounting into driving position, with the side stand in place, is permitted only to prevent the possibility of the vehicle falling or overturn, and does not indicate the possibility for the rider and passenger's weight to be placed on the side stand.

During mounting and dismounting the vehicle's weight can cause a loss of balance, with consequent loss of equilibrium and the possibility of falling or overturning.

CAUTION

THE RIDER SHOULD ALWAYS BE THE FIRST TO MOUNT AND THE LAST TO DISMOUNT FROM THE VEHICLE, AND SHOULD CONTROL THE STABILITY AND EQUILIBRIUM OF THE VEHICLE WHILE THE PASSENGER IS MOUNTING AND DISMOUNTING

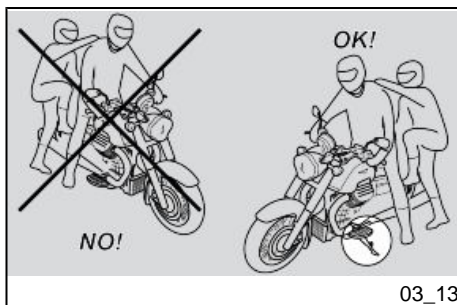

In any case, the passenger should mount and dismount the vehicle using caution to avoid causing the vehicle or the rider to lose balance.

CAUTION

THE RIDER TO INSTRUCT THE PASSENGER ABOUT THE PROPER WAY TO MOUNT AND DISMOUNT FROM THE VEHICLE.

THE VEHICLE INCLUDES PASSENGER FOOTRESTS WHICH SHOULD BE USED DURING MOUNTING AND DISMOUNTING. THE PASSENGER SHOULD ALWAYS USE THE LEFT FOOTREST FOR MOUNTING AND DISMOUNTING FROM THE VEHICLE.

DO NOT DISMOUNT OR EVEN ATTEMPT TO DISMOUNT BY JUMPING OR STRETCHING OUT YOUR LEG IN ORDER TO TOUCH THE GROUND. IN BOTH CASES THE STABILITY AND EQUILIBRIUM OF THE VEHICLE COULD BE COMPROMISED.

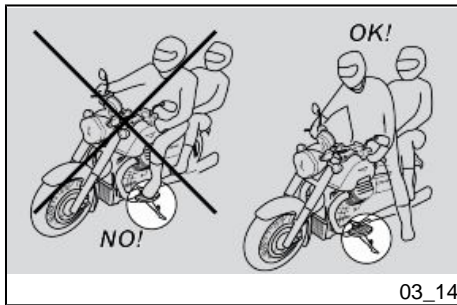

CAUTION

BAGGAGE OR OBJECTS ATTACHED TO THE REAR PART OF THE VEHICLE CAN CREATE AN OBSTACLE DURING MOUNTING AND DISMOUNTING FROM THE VEHICLE.

IN ALL CASES, THINK AHEAD AND MOVE YOUR RIGHT LEG CAREFULLY, AS IT WILL HAVE TO AVOID AND CLEAR THE REAR PART OF THE VEHICLE (INCLUDING BAGGAGE AND THE TAIL FAIRING) WITHOUT CAUSING LOSS OF BALANCE.

MOUNTING

- Grip the handlebar properly and mount the vehicle without placing your weight upon the side stand.

CAUTION

IN THE CASE THAT YOU ARE NOT ABLE TO REST BOTH FEET ON THE GROUND, PUT THE RIGHT FOOT ON THE GROUND, (IN THE CASE OF A LOSS OF BALANCE THE LEFT SIDE IS "PROTECTED" BY THE SIDE STAND) AND KEEP YOUR LEFT FOOT READY TO BE POSITIONED.

- Place both feet on the ground and straighten the vehicle into the driving position, always maintaining its equilibrium.

CAUTION

THE RIDER SHOULD NOT OPEN OR TRY TO OPEN THE PASSENGER FOOTRESTS FROM THE RIDER'S SEAT, AS IT COULD COMPROMISE THE STABILITY AND EQUILIBRIUM OF THE VEHICLE.

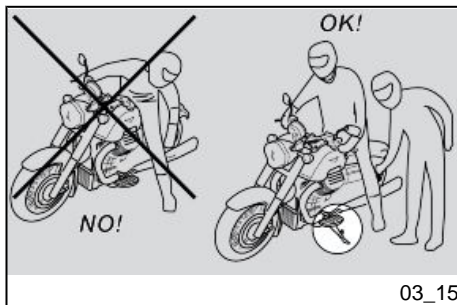

03_15

- Have the passenger open the two passenger foot pegs.
- Show the passenger how to mount the vehicle.
- Use your left foot to push on the side stand and make it fully return to its position.

DISMOUNTING

- Select an appropriate parking spot.
- Stop the vehicle.



MAKE SURE THAT THE GROUND ON WHICH THE MOTORCYCLE IS PARKED IS FIRM, EVEN AND FREE OF OBSTACLES.

- Use the heel of your left foot to completely open the side stand.

CAUTION

IN THE CASE THAT YOU ARE NOT ABLE TO REST BOTH FEET ON THE GROUND, PUT THE RIGHT FOOT ON THE GROUND, (IN THE CASE OF A LOSS OF BALANCE THE LEFT SIDE IS "PROTECTED" BY THE SIDE STAND) AND KEEP YOUR LEFT FOOT READY TO BE POSITIONED.

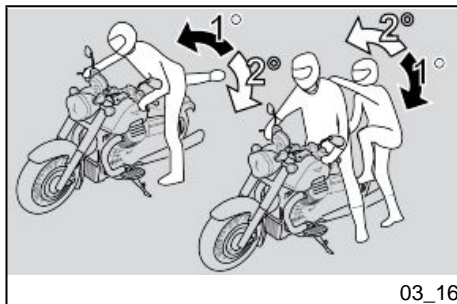

03_16

- Place both feet on the ground and keep the vehicle balanced in the driving position.
- Show the passenger how to dismount from the vehicle.



RISK OF FALLING OR OVERTURNING.

MAKE SURE THAT THE PASSENGER HAS DISMOUNTED FROM THE VEHICLE.

DO NOT PLACE YOUR WEIGHT UPON THE SIDE STAND.

- Lean the motorcycle until the stand touches the ground.
- Correctly grip the handlebar, and dismount from the vehicle.
- Turn the handlebar completely to the left.
- Place the passenger footrest in its place.

CAUTION



MAKE SURE THE VEHICLE IS STABLE.

V9 Roamer - V9 Bobber



**Chap. 04
Maintenance**

Foreword

In general terms, scheduled maintenance can be carried out by the owner; however, some operations may require specific tools and technical training. For periodic maintenance, servicing or technical advice, contact an **Official Moto Guzzi Dealer** for prompt and accurate service.

WARNING

THIS VEHICLE HAS BEEN PROGRAMMED TO INDICATE IN REAL TIME ANY ACTIVATION FAILURE STORED IN THE ELECTRONIC CONTROL UNIT MEMORY.

ANY TIME THE IGNITION SWITCH IS SET TO "ON", THE "GENERAL ALARM" WARNING LIGHT ON THE INSTRUMENT PANEL TURNS ON FOR THREE SECONDS. IF THE WARNING LIGHT TURNS OFF, IT MEANS THAT THERE ARE NO MALFUNCTIONS.

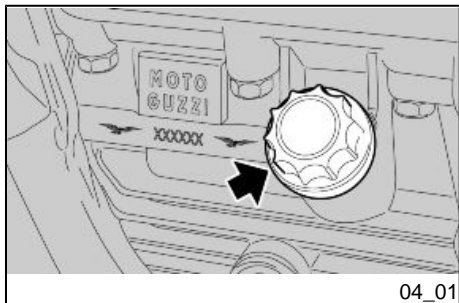

Engine oil level check (04_01, 04_02)

Check the engine oil level frequently.

NOTE

CARRY OUT MAINTENANCE OPERATIONS AT HALF THE INTERVALS SPECIFIED IF THE VEHICLE IS USED IN PARTICULAR RAINY OR DUSTY CONDITIONS, OFF ROAD OR FOR TRACK USE.

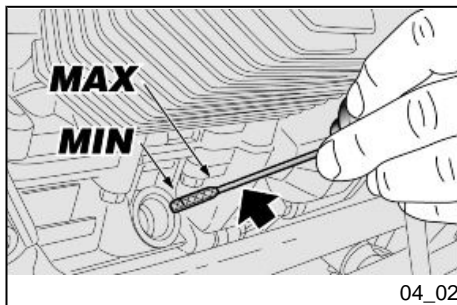

To check:



THE ENGINE MUST BE WARM TO CHECK OIL LEVEL AND THE FILLER PLUG / DIPSTICK FULLY SCREWED IN.

IF YOU CHECK LEVEL WHEN THE ENGINE IS COLD, OIL LEVEL COULD TEMPORARILY DROP BELOW THE 'MIN' MARK.

THIS IS NOT INDICATIVE OF A PROBLEM PROVIDED THAT IT IS NOT ACCOMPANIED BY THE GENERAL ALARM WARNING LAMP ILLUMINATING AND THE MESSAGE "ALARM OIL PRESSURE" APPEARING ON THE DISPLAY.

CAUTION

DO NOT LET THE ENGINE IDLE WITH THE VEHICLE AT A STANDSTILL TO WARM UP THE ENGINE AND OBTAIN THE OPERATING TEMPERATURE OF ENGINE OIL.

PREFERABLY CHECK THE OIL AFTER A JOURNEY OF AFTER TRAVELLING APPROXIMATELY 15 Km (9.32 miles) IN EXTRAURBAN CONDITIONS (ENOUGH TO WARM UP THE ENGINE OIL TO OPERATING TEMPERATURE).

- Shut off the engine.
- Keep the vehicle upright with both wheels on the ground.
- Unscrew and remove the filler plug / oil dipstick, and wipe it clean.
- Fit the oil filler plug / oil dipstick and tighten fully.
- Unscrew and remove the filler plug / oil dipstick and check that the oil level is correct.

'MAX' = maximum level.

'MIN' = minimum level.

The difference between **'MAX'** and **'MIN'** marks is approx. 400 cm³ (24.41 cu.in)

- The oil level is correct when it is close to the **'MAX'** mark.

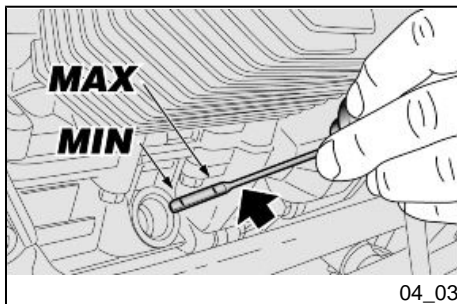
**CAUTION**

DO NOT GO BEYOND THE "MAX" AND BELOW THE "MIN" LEVEL MARK TO AVOID SEVERE ENGINE DAMAGE.

Engine oil top-up (04_03)

Fill with engine oil as required:

- Unscrew and remove the filler plug.



DO NOT ADD ADDITIVES OR ANY OTHER SUBSTANCES TO THE OIL.

When using a funnel or any other element, make sure it is perfectly clean.

CAUTION

USE HIGH-QUALITY 10W - 60 OIL.

- Top up oil until reaching the correct level.

Engine oil change (04_04, 04_05, 04_06)



CHANGING ENGINE OIL AND ENGINE OIL FILTER CAN PROVE DIFFICULT IF YOU ARE INEXPERIENCED.

TAKE YOUR VEHICLE TO AN Official Moto Guzzi Dealer IF NECESSARY.

IF YOU WISH TO PERFORM THESE OPERATIONS YOURSELF, FOLLOW THESE INSTRUCTIONS.

NOTE

CARRY OUT MAINTENANCE OPERATIONS AT HALF THE INTERVALS SPECIFIED IF THE VEHICLE IS USED IN PARTICULAR RAINY OR DUSTY CONDITIONS, OFF ROAD OR FOR TRACK USE.

Check the engine oil level frequently.

To change the oil:

CAUTION

HOT OIL IS MORE FLUID AND WILL DRAIN OUT MORE EASILY AND COMPLETELY; IDEAL TEMPERATURE IS REACHED AFTER THE ENGINE HAS RUN FOR ABOUT TWENTY MINUTES.



OIL BECOMES VERY HOT WHEN THE ENGINE IS HOT; BE CAREFUL NOT TO GET BURNED WHEN CARRYING OUT THE OPERATIONS DESCRIBED BELOW.

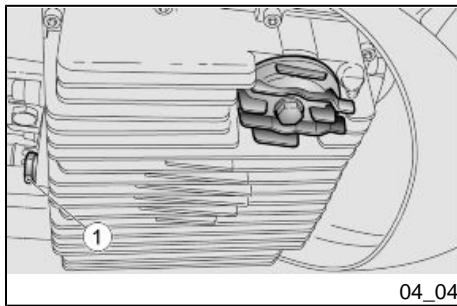

04_04

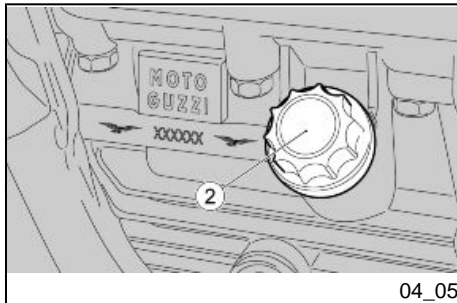

04_05

- Place a recipient with a capacity of at least 2000 cm³ (122.05 cu.in) under the drain plug (1).
- Unscrew and remove the drainage plug (1).
- Drain the oil into the container; allow several minutes for oil to drain out completely.
- Check and if necessary, replace the sealing washer of drainage plug (1).
- Remove any metal deposits attached to the drainage plug (1) magnet.
- Screw and tighten the drainage plug (1).

Tightening torque for drainage plugs (1): 20 - 22 Nm (14.75 - 16.23 lb ft).



DO NOT DISPOSE OF OIL INTO THE ENVIRONMENT.

DISPOSE OF ENGINE OIL IN A SEALED CONTAINER AND TAKE IT TO YOUR SUPPLIER OR TO THE NEAREST USED OIL COLLECTION CENTRE.

Engine oil filter replacement

NOTE

CARRY OUT MAINTENANCE OPERATIONS AT HALF THE INTERVALS SPECIFIED IF THE VEHICLE IS USED IN PARTICULAR RAINY OR DUSTY CONDITIONS, OFF ROAD OR FOR TRACK USE.

CAUTION

REPLACE THE ENGINE OIL FILTER EVERY 10,000 KM (6213.71 MILES) (OR EACH TIME YOU CHANGE THE ENGINE OIL).

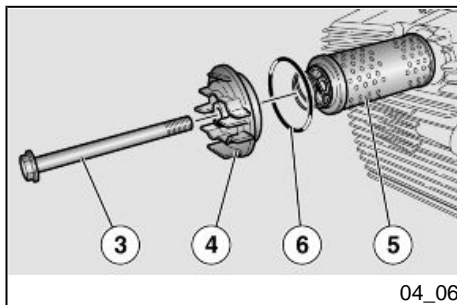

- Undo the two screws (3) and remove the cover (4).
- Remove the engine oil filter (5).

NOTE

NEVER REUSE AN OLD FILTER.

- Spread a thin layer of oil on the sealing ring (6) of the new engine oil filter.
- Fit the new engine oil filter with the spring facing downwards.
- Refit the cover (4), screw and tighten the screw (3).

Bevel gear pair oil level (04_07)

NOTE

CARRY OUT MAINTENANCE OPERATIONS AT HALF THE INTERVALS SPECIFIED IF THE VEHICLE IS USED IN PARTICULAR RAINY OR DUSTY CONDITIONS, OFF ROAD OR FOR TRACK USE.

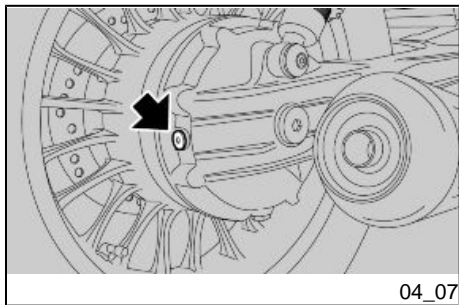

04_07

Check the cardan shaft oil level regularly; change the oil at the specified intervals according to the scheduled maintenance table

To check:

- Keep the vehicle upright with both wheels on the ground.
- Unscrew and remove the level plug.
- Check that the oil level is on the rim of the hole of the level plug. Top-up if oil is below the specified level.

CAUTION

CHECK THE CONDITION OF THE SEALING WASHER OF THE LEVEL PLUG IN CASE OF CHECK OF THE OIL IN THE CARDAN SHAFT TRANSMISSION UNIT. IT IS ALSO RECOMMENDED TO REPLACE SUCH WASHER AT AN AUTHORIZED Moto Guzzi Dealer.

CAUTION

TO TOP-UP OR CHANGE THE OIL IN THE CARDAN SHAFT TRANSMISSION UNIT, CONTACT AN Official Moto Guzzi Dealer.

Gearbox oil level

CAUTION

THE GEARBOX OIL MUST BE CHECKED AND CHANGED BY AN Official Moto Guzzi Dealership.

Tyres (04_08, 04_09, 04_10)

This vehicle is fitted with tyres without inner tubes (Tubeless).

CAUTION

TRACTION CONTROL (MGCT) IS SET, AT THE END OF THE PRODUCTION OF THE VEHICLE, ON LEVEL «2» AND MUST BE KEPT ACTIVE FOR THE ENTIRE RUNNING PERIOD, TO ALLOW THE CORRECT ADJUSTMENT OF THE TYRES TO ASPHALT CONDITIONS.

THE SAME NOTE ALSO APPLIES WHEN CHANGING THE TYRES.

CAUTION



TO ALLOW THE QUICK REACHING OF THE PERFECT GRIP OF NEW TYRES AT THE FIRST MILEAGE, IT IS RECOMMENDED A PARTICULARLY CAREFUL GUIDE OF THE MOTORCYCLE, AVOIDING SUDDEN STEERING OR VIOLENT ACCELERATION AND BRAKING.

CAUTION

CHECK TYRE INFLATION PRESSURE REGULARLY AT AMBIENT TEMPERATURE. THE MEASUREMENT MAY BE INCORRECT IF TYRES ARE WARM. CHECK TYRE PRESSURE MAINLY BEFORE AND AFTER A LONG TRIP. AN OVER-INFLATED TYRE WILL PROVIDE A HARSH RIDE AS SURFACE UNEVENNESS IS NOT CUSHIONED AND IS SENT TO THE HANDLEBAR, THUS REDUCING GRIP AND ROAD HOLDING SPECIALLY WHEN CORNERING.

ON THE OTHER HAND, AN UNDER-INFLATED TYRE CAUSES THE CONTACT PATCH TO INCLUDE A LARGER PORTION OF THE TYRE SIDE WALLS. IF SO, THE TYRE MIGHT SLIP ON OR GET DETACHED FROM THE WHEEL RIM, RESULTING IN LOSS OF CONTROL OVER THE VEHICLE.

TYRES MAY EVEN DETACH FROM THE WHEEL RIMS UNDER VERY HARD BRAKING.

EVENTUALLY THE VEHICLE MIGHT SKID IN A BEND.

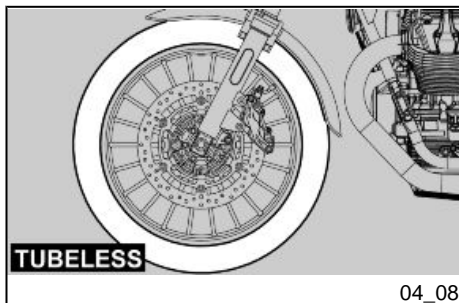

04_08

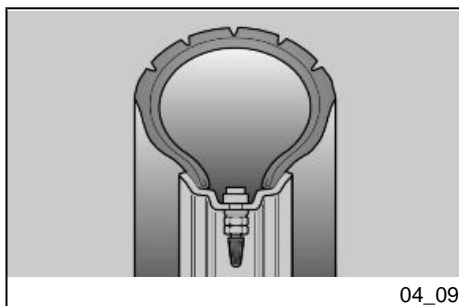

04_09

CHECK THE SURFACE CONDITION AND WEAR BECAUSE POOR TYRE CONDITION COULD COMPROMISE GRIP AND HANDLING OF THE VEHICLE.

SOME TYRE TYPES APPROVED FOR THIS VEHICLE FEATURE WEAR INDICATORS.

THERE ARE SEVERAL TYPES OF WEAR INDICATORS. CONSULT YOUR DEALER ON METHODS TO CHECK FOR WEAR.

CARRY OUT A VISUAL INSPECTION FOR TYRE WEAR AND TEAR, REPLACE TYRES WHEN WORN.

WHEN TYRES ARE OLD, THE MATERIAL MAY HARDEN AND NOT PROVIDE ADEQUATE ROAD HOLDING, EVEN IF TYRES ARE STILL WITHIN THE WEAR LIMIT. REPLACE TYRES IF THIS OCCURS. REPLACE THE TYRE IF IT IS WORN OR IF THERE IS A PUNCTURE LARGER THAN 5 mm (0.197 in) IN THE TREAD AREA.

WHEEL MUST BE BALANCED AFTER A TYRE IS MENDED.

USE ONLY TYRE SIZES INDICATED BY THE MANUFACTURER. DO NOT FIT TYRES WITH INNER TUBES ON RIMS FOR TUBELESS TYRES OR VICE VERSA. CHECK THAT THE INFLATION VALVES HAVE THEIR CAPS FITTED TO AVOID UNEXPECTED FLAT TYRES.

REPLACEMENT, REPAIR, MAINTENANCE AND BALANCING OPERATIONS ARE HIGHLY IMPORTANT AND SO THEY SHOULD BE CARRIED OUT USING THE SPECIFIC TOOLS AND WITH THE ADEQUATE KNOWLEDGE. HAVE YOUR TYRES AND WHEELS SERVICED AT AN OFFICIAL DEALER OR A SPECIALISED TYRE WORKSHOP.

NEW TYRES MAY BE COATED WITH AN OILY FILM: RIDE WITH CAUTION DURING THE FIRST KILOMETRES. DO NOT APPLY UNSUITABLE LIQUIDS ON TYRES.

WHEN TYRES ARE OLD, THE MATERIAL MAY HARDEN AND NOT PROVIDE ADEQUATE ROAD HOLDING, EVEN IF TYRES ARE STILL WITHIN THE WEAR LIMIT.

SHOULD THIS OCCUR, REPLACE THE TYRES.

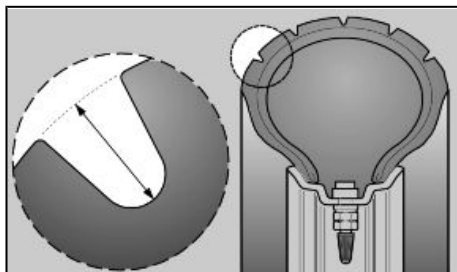

04_10

Minimum tread depth:

front and rear 2 mm (0.079 in) (USA 3 mm) (USA 0.118 in) and anyway not lower to what it is specified in the current legislation in the country in which the vehicle is used.

Spark plug dismantlement**CAUTION**

FOR REMOVAL, CHECK, AND REPLACEMENT OF THE SPARK PLUGS CONTACT AN OFFICIAL Moto Guzzi Dealer.

Removing the sides (04_11)

- Remove the saddle.
- Undo and remove the three fastener screws (1) and remove the side fairing (2).

NOTE

HANDLE PAINTED AND PLASTIC COMPONENTS WITH CARE; BE CAREFUL NOT TO SCRATCH OR DAMAGE THEM.

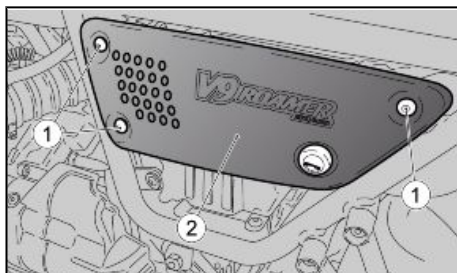

04_11

- Repeat the operations to remove the other fairing.

The right hand side fairing can be removed completely from the motorcycle.

The left hand side fairing (2) can only be detached, as is kept connected to the frame by the saddle lock release cable.

Removing the air filter

CAUTION

TO REMOVE, CHECK AND REPLACE THE AIR FILTER, CONTACT AN Official Moto Guzzi Dealer.

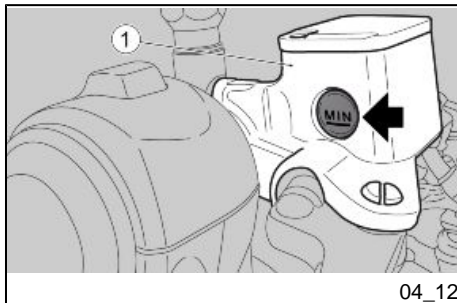

Checking the brake oil level (04_12, 04_13)

FRONT BRAKE

CHECK

- Rest the vehicle on its stand
- Turn the handlebar so that the fluid is at the same level as the plug.
- Check that the fluid contained in the tank (1) exceeds the '**MIN**' level reference mark

MIN = minimum level

If the fluid does not reach at least the "**MIN**" reference mark:

CAUTION

FLUID LEVEL DECREASES GRADUALLY AS BRAKE PADS WEAR DOWN.

- Check brake pads and discs for wear.

If the brake pads and/or brake discs do not have to be replaced, have the braking system checked at an **Official Moto Guzzi Dealership**.

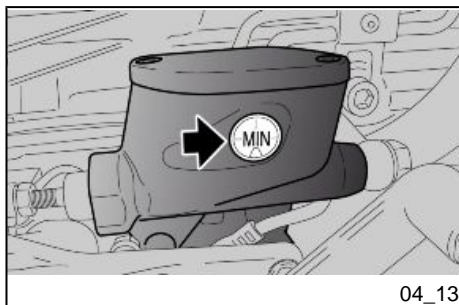

04_13

REAR BRAKE

CHECK

- Keep the vehicle upright so that the fluid in the reservoir is at the same level as the plug.
- Make sure that the fluid level in the reservoir is above the "MIN" reference mark:.

MIN = minimum level

If the fluid does not reach at least the "MIN" reference mark:

CAUTION

FLUID LEVEL DECREASES GRADUALLY AS BRAKE PADS WEAR DOWN.

- Check brake pads and discs for wear.

If the brake pads and/or brake discs do not have to be replaced, have the braking system checked at an **Official Moto Guzzi Dealership**.

Braking system fluid top up

CAUTION

FOR THE TOP-UP OF THE BRAKING SYSTEMS COOLANT, CONTACT AN Official Moto Guzzi Dealer.

Use of a new battery (04_14, 04_15)



REMOVING THE BATTERY RESETS THE DIGITAL CLOCK AND THE TRIP JOURNAL FUNCTIONS.

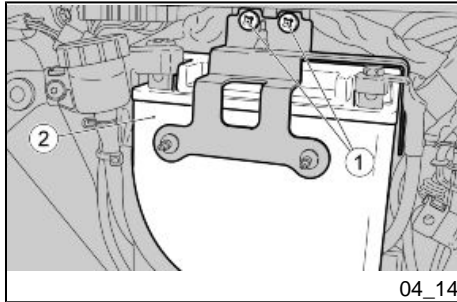

- Make sure the ignition switch is set to 'KEY OFF'.
- Remove the rider saddle.
- Remove the right hand side fairing.
- Undo the two fastener screws (1) in order to be able to pull out the battery (2) sufficiently to undo the screws on the terminal clamps.

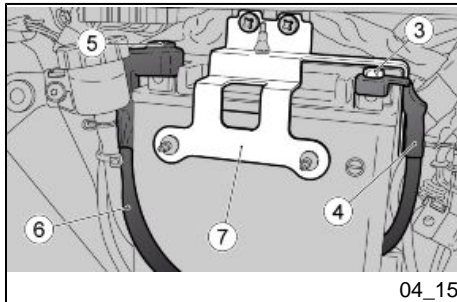

- Unscrew and remove the screw (3) of the negative terminal (-).
- Move the negative lead (4) aside.
- Unscrew and remove the screw (5) of the positive terminal (+).
- Move the positive lead (6) aside.
- Remove the battery retainer bracket (7)
- Grip the battery (2) firmly and remove from its seat.

CAUTION



ONCE REMOVED THE BATTERY MUST BE PUT AWAY IN A SAFE PLACE AND OUT OF THE REACH OF CHILDREN.

- Put the battery away on a level surface, in a cool and dry place.
- Place the fixing bracket (2) and refit the screws (1).
- Refit the left side fairing.
- Refit the rider saddle.

CAUTION

UPON REFITTING, CONNECT THE LEAD TO THE POSITIVE TERMINAL (+) FIRST AND AFTERWARDS THE LEAD TO THE NEGATIVE TERMINAL (-).

CAUTION

TO INSTALL A NEW BATTERY FOLLOW THE OPERATIONS DESCRIBED ABOVE BUT IN REVERSE ORDER.



CHECK THAT THE CABLE TERMINALS AND BATTERY LEADS ARE:

- IN GOOD CONDITION (NOT CORRODED OR COVERED BY DEPOSITS);
- COVERED BY NEUTRAL GREASE OR PETROLEUM JELLY.

Checking the electrolyte level

WARNING

THIS VEHICLE IS FITTED WITH A MAINTENANCE-FREE BATTERY AND DOES NOT NEED ANY INTERVENTION, EXCEPT FOR SPORADIC CHECKS AND RECHARGE.

Charging the battery

- Remove the battery.
- Get an adequate battery charger.
- Set the battery charger for the recharge type indicated.

- Connect the battery to the battery charger.

CAUTION

WHEN RECHARGING OR USING THE BATTERY, BE CAREFUL TO HAVE THE ROOM ADEQUATELY AIRED. DO NOT BREATHE GASES RELEASED WHEN THE BATTERY IS RECHARGING.

Switch on the battery charger.

Characteristic**CHARGE MODES**

Recharge - Ordinary

Electric Current - 1.8A

Time - 8-10 hours

Long periods of inactivity

If the vehicle is inactive longer than fifteen days, it is necessary to recharge the battery to avoid sulphation.

- Remove the battery and put it away in a cool and dry place.

In winter or when the vehicle remains stopped, check the charge frequently (about once a month) to avoid deterioration.

- Recharge it fully with an ordinary charge.

If the battery is still installed in the vehicle, disconnect the cables from the terminals.

CHECKING AND CLEANING TERMINALS AND LEADS

- Partially remove the battery from its housing.
- Check that the cable terminals and battery leads are:
 - in good conditions (not corroded or covered by deposits);
 - covered by neutral grease or petroleum jelly.

Fuses (04_16, 04_17, 04_18, 04_19)

CAUTION



DO NOT REPAIR FAULTY FUSES.

NEVER USE A FUSE THAT IS DIFFERENT THAN WHAT IS SPECIFIED TO PREVENT DAMAGES TO THE ELECTRICAL SYSTEM OR SHORT CIRCUITS, AND THE RISK OF FIRE.

NOTE

A FUSE THAT BLOWS FREQUENTLY MAY INDICATE A SHORT CIRCUIT OR OVERLOAD. IF THIS OCCURS, CONTACT AN Official Guzzi Dealer.

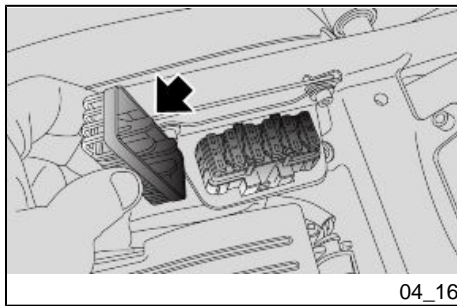

04_16

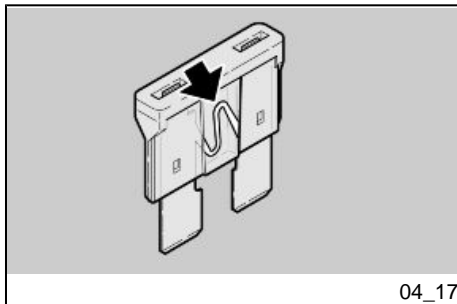

04_17

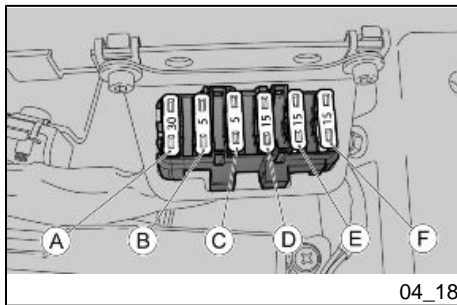

04_18

To check:

- Set the ignition switch to 'OFF' to avoid an accidental short circuit.
- Remove the saddle.
- Remove the fuse box cover.
- Take out one fuse at a time and check if the filament is broken.
- Before replacing the fuse, find and solve, if possible, the reason that caused the problem.
- If the fuse is damaged, replace it with one of the same current rating.

NOTE

IF THE SPARE FUSE IS USED, REPLACE WITH ONE OF THE SAME TYPE IN THE CORRESPONDING FITTING.

FUSE LOCATION

- A) Main fuse, coil 1 and 2, injector 1 and 2, oxygen sensor 1 and 2 (30 A).
 B) (Battery positive) MIU G3 ECU (5 A).
 C) (Battery positive) Instrument panel, turn indicators, bluedash (5 A).
 D) ECU, engine kill, start relay, instrument panel, injection loads relay (15 A).
 E) Provision for GPS, low beam / high beam, passing, USB, bluedash (15 A).
 F) Brake light, running lights, horn (15 A).

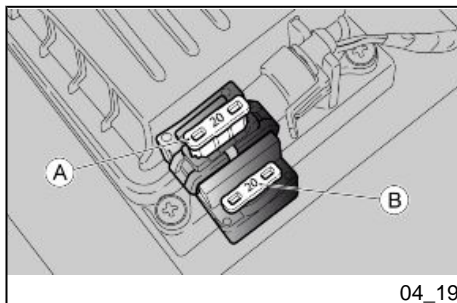

ABS FUSE DISTRIBUTION

- A) ABS Control unit (20 A).
- B) Spare fuses (20 A).

Lamps (04_20, 04_21, 04_22)

CAUTION



BEFORE REPLACING A BULB, TURN THE IGNITION SWITCH TO «KEY OFF» AND WAIT A FEW MINUTES FOR THE BULB TO COOL OFF.

WEAR CLEAN GLOVES OR USE A CLEAN DRY CLOTH TO REPLACE THE BULB.

DO NOT LEAVE PRINTS ON THE BULB AS THIS MAY CAUSE IT TO OVERHEAT OR EVEN BLOW OUT. IF YOU TOUCH THE BULB WITHOUT WEARING GLOVES, CLEAN OFF PRINTS WITH ALCOHOL TO AVOID DAMAGING THE BULB.

DO NOT FORCE ELECTRICAL CABLES.

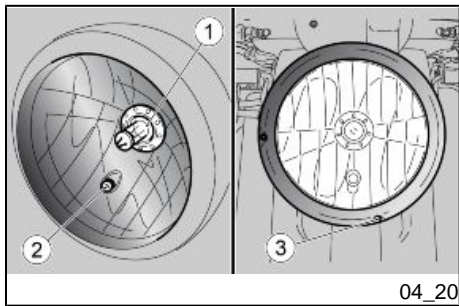

BULB LAYOUT

In the headlamp there are:

- one high beam / low beam bulb (1) (upper);
- one tail light bulb (2) (lower);

FRONT HEADLAMP BULB REPLACEMENT

- Rest the vehicle on its stand.
- Remove the complete paraboloid from the headlight body by undoing the screw (3).

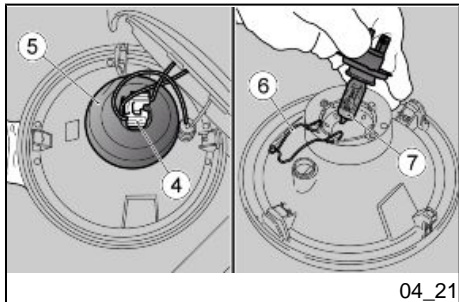

LOW BEAM / HIGH BEAM LIGHT BULB

- Pull out the electrical connection to the bulb (4), and disconnect it from the bulb.
- Move hood (5) manually.
- Release the two ends of the retaining spring (6) located on the bulb holder.
- Pull the bulb (1) out of its seat.

NOTE

INSERT THE BULB INTO THE BULB HOLDER, MAKING SURE THE REFERENCE FITTINGS MATCH.

- Install a bulb of the same type adequately.

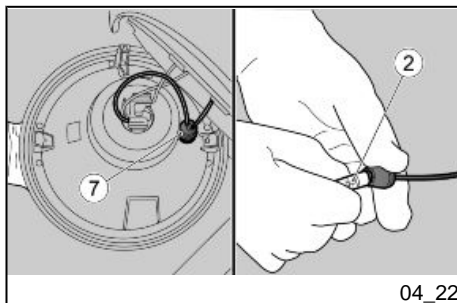

TAIL LIGHT BULB

- Pull out the tail light bulb holder (7) from its seat.
- Remove the bulb (2) and replace it with another of the same type.
- Check the proper insertion of the bulb in the bulb holder.

Headlight adjustment (04_23, 04_24, 04_25)

NOTE

IN COMPLIANCE WITH LOCAL LEGAL REQUIREMENTS, SPECIFIC PROCEDURES MUST BE FOLLOWED WHEN CHECKING LIGHT BEAM ADJUSTMENT.

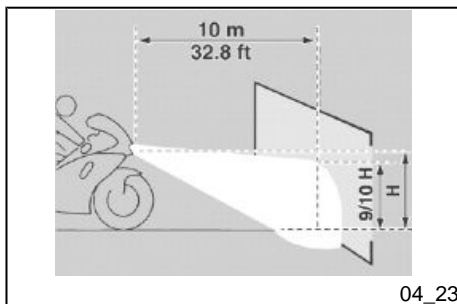

For a quick check of the correct direction of the front light beam:

- Place the vehicle 10 m (32.8 ft) from a vertical wall and make sure the ground is level.
- Turn on the low beam light, sit on the vehicle and check that the light beam projected to the wall is a little below the headlight horizontal straight line (about 9/10 of the total height).

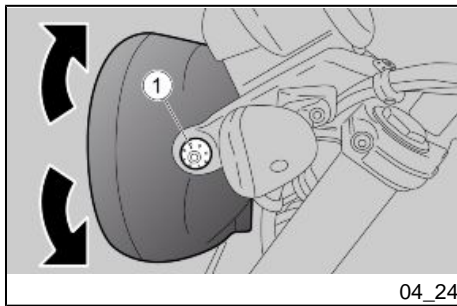

In order to carry out vertical adjustment of the light beam:

- Stand the motorcycle in a vertical position.
- Slightly loosen the headlight fixing screws (1), and move the light beam manually to the desired position.
- Once the adjustment is finished tighten the screws (1).

After adjusting:

NOTE

CHECK THAT THE LIGHT BEAM VERTICAL DIRECTION IS CORRECT.

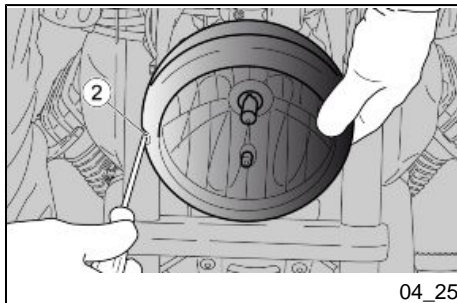

In order to carry out horizontal adjustment of the light beam:

- Stand the motorcycle in a vertical position.
- Actuating on the screw (2) adjust the direction of the light beam.

After adjusting:

NOTE

CHECK THAT THE LIGHT BEAM HORIZONTAL DIRECTION IS CORRECT.

Front direction indicators (04_26, 04_27)

- Rest the vehicle on its stand.
- Loosen and remove screw (1).

NOTE

REMOVE THE PROTECTION GLASS WITH CAUTION SO AS NOT TO BREAK THE FITTING TOOTH.

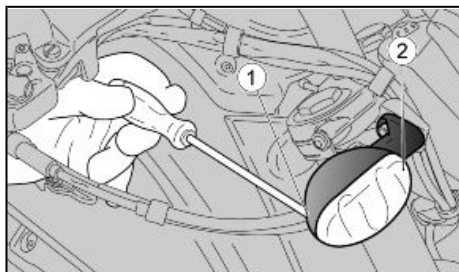

04_26

- Remove the protective glass (2).

CAUTION

UPON REFITTING, POSITION THE PROTECTIVE GLASS CORRECTLY IN ITS POSITION.

TIGHTEN THE SCREW (1) CAREFULLY AND MODERATELY TO AVOID DAMAGING THE PROTECTIVE GLASS.

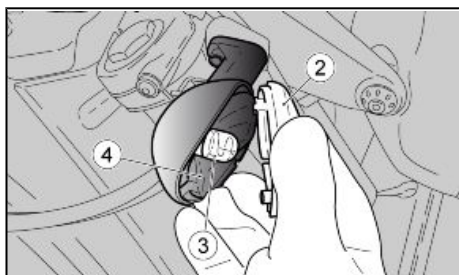

04_27

- Press bulb (3) slightly and turn it anticlockwise.
- Pull the bulb (3) out of its fitting.

NOTE

INSERT THE BULB IN THE BULB HOLDER SO THAT THE TWO GUIDING PINS COINCIDE WITH THEIR GUIDES ON THE BULB HOLDER.

- Install a bulb of the same type adequately.

NOTE

IF THE BULB HOLDER «4» IS STICKS OUT ITS FITTING, INSERT IT AGAIN CORRECTLY BY MATCHING THE BULB HOLDER RADIAL OPENING WITH THE SCREW SEAT.

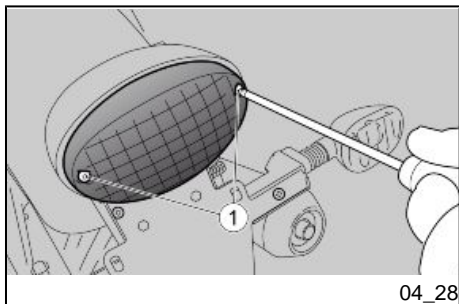
**Rear optical unit (04_28, 04_29, 04_30)**

- Rest the vehicle on its stand.
- Undo and remove the two screws (1).

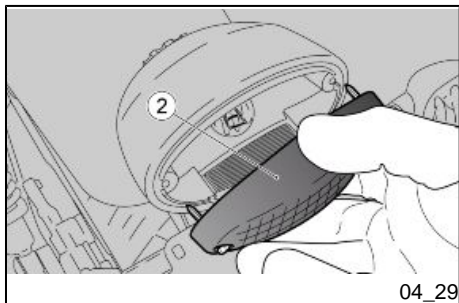

- Remove the protective glass (2) with caution.

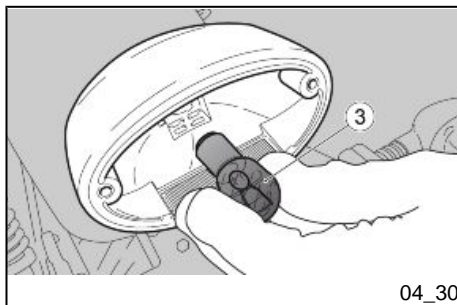

04_30

- Press bulb (3) slightly and turn it anticlockwise.
- Pull the bulb (3) out of its fitting.
- Insert a bulb of equal rating in the bulb holder making the two guiding pins coincide with their guides on the bulb holder.
- Tighten the two screws (1) carefully and moderately so as to avoid damaging the protective glass (2).

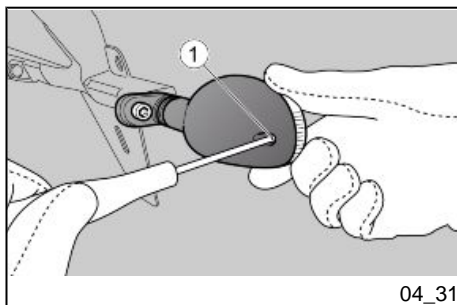

04_31

Rear turn indicators (04_31, 04_32)

- Rest the vehicle on its stand.
- Loosen and remove screw (1).

NOTE

REMOVE THE PROTECTION GLASS WITH CAUTION SO AS NOT TO BREAK THE FITTING TOOTH.

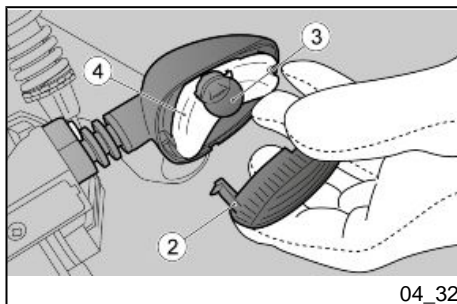

04_32

- Remove the protective glass (2).

CAUTION

UPON REFITTING, POSITION THE PROTECTIVE GLASS CORRECTLY IN ITS POSITION.

TIGHTEN THE SCREW (1) CAREFULLY AND MODERATELY TO AVOID DAMAGING THE PROTECTIVE GLASS.

- Press bulb (3) slightly and turn it anticlockwise.
- Pull the bulb (3) out of its fitting.

NOTE

INSERT THE BULB IN THE BULB HOLDER SO THAT THE TWO GUIDING PINS COINCIDE WITH THEIR GUIDES ON THE BULB HOLDER.

- Install a bulb of the same type adequately.

NOTE

IF THE BULB HOLDER «4» IS STICKS OUT ITS FITTING, INSERT IT AGAIN CORRECTLY BY MATCHING THE BULB HOLDER RADIAL OPENING WITH THE SCREW SEAT.

Rear-view mirrors (04_33, 04_34)

DO NOT RIDE WITH REAR-VIEW MIRRORS INCORRECTLY SET.

ALWAYS CHECK THAT THE MIRRORS ARE ADJUSTED CORRECTLY BEFORE SETTING OFF.

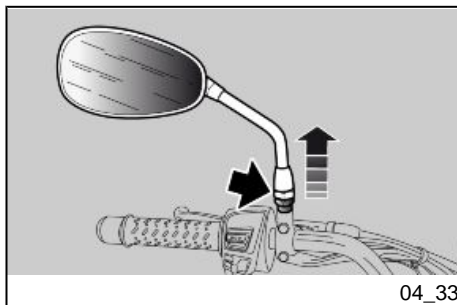

04_33

Rear-view mirrors removal:

- Rest the vehicle on its stand.
- Loosen the locking nut.
- Slide up and remove the complete rear-view mirror unit.

Repeat the procedure to remove the other rear-view mirror, if necessary.



UPON REFITTING AND BEFORE TIGHTENING THE LOCKING NUT, MAKE SURE THAT THE REAR VIEW MIRROR SUPPORT STEM IS ALIGNED WITH THE HANDLEBAR.

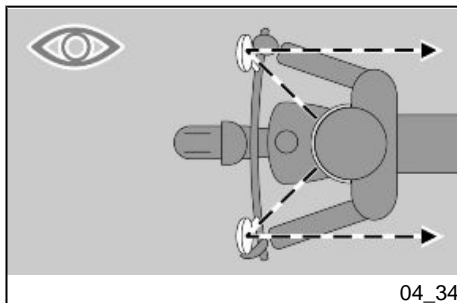

04_34

Rear-view mirrors adjustment:

- Get onto the bike in the riding position.
- Turn the mirror, correctly adjusting the inclination.

Repeat the procedure to adjust the other mirror.

- Make sure there is no dirt or mud.

Front and rear disc brake (04_35, 04_36)**CAUTION**

A DIRTY DISC SMEARS THE PADS RESULTING IN POOR BRAKING.

REPLACE DIRTY PADS AND CLEAN AGAIN THE DIRTY DISC USING A TOP QUALITY DEGREASING PRODUCT.

CAUTION

TAKE YOUR VEHICLE TO AN Official Moto Guzzi Dealer TO HAVE THE REAR WHEEL REMOVED.

CAUTION



CHECK BRAKE PADS FOR WEAR MAINLY BEFORE EACH RIDE.

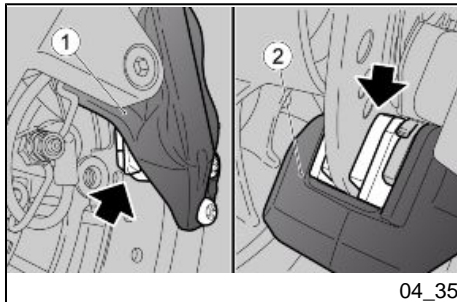

To perform a quick pad wear check:

- Rest the vehicle on its stand.
- Carry out a visual inspection of brake disc and pads as follows:
 - at the bottom front, to check the front brake calliper (1);
 - from the bottom rear side to check the rear brake calliper (2);

CAUTION

EXCESSIVE WEAR OF THE FRICTION MATERIAL MAKES THE PAD METAL SUPPORT GET INTO CONTACT WITH THE DISC, WHICH RESULTS IN A METALLIC NOISE AND SPARKS IN THE CALLIPER; THEREFORE, BRAKING EFFICIENCY AND DISC SAFETY AND INTEGRITY ARE AT RISK.

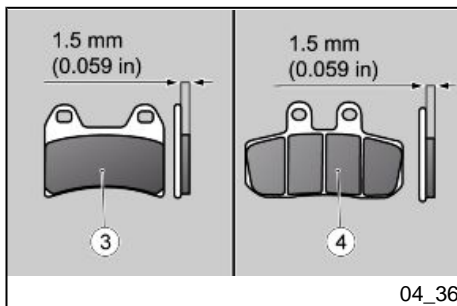

If the friction material thickness (even of one front (3) or rear (4) pad) is reduced to a value of about **1.5 mm (0.059 in)** (or even if one of the wear indicators is not very visible), contact an **Official Moto Guzzi Dealer** to replace all the brake callipers.

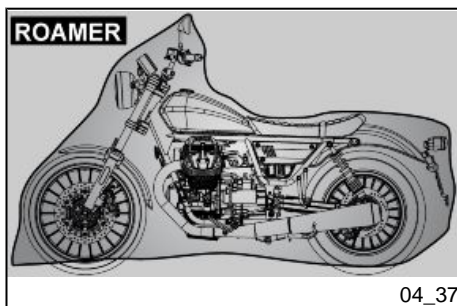

Periods of inactivity (04_37, 04_38)

Take some measures to avoid the side effects of not using the scooter. Besides, it is necessary to carry out general repairs and checks before garaging the motorcycle as one can forget to do so afterwards.

Proceed as follows:

- Remove the battery.
- Wash and dry the motorcycle.
- Apply wax polish to painted and chromed surfaces.
- Inflate the tyres.
- Set the vehicle in a room with no heating or humidity, with minimum temperature variations and not exposed to sun rays.
- Wrap and tie a plastic bag around the exhaust pipe opening to keep moisture out.

CAUTION

PLACE THE VEHICLE ON SUITABLE SUPPORTS TO KEEP THE TYRES OFF THE GROUND.

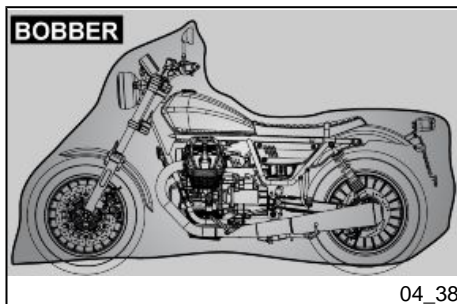

Cover the vehicle but do not use plastic or waterproof materials.

CAUTION

TO AVOID BATTERY DETERIORATION, FOLLOW THE PROCEDURE DESCRIBED FOR PROLONGED INACTIVITY.

AFTER STORAGE

NOTE

TAKE THE PLASTIC BAGS OFF THE EXHAUST PIPE OPENING.

- Uncover and clean the vehicle.
- Check the battery for correct charge and install it.
- Refill the fuel tank.
- Carry out the pre-ride checks.

CAUTION



AS A TEST, RIDE THE MOTORCYCLE FOR A FEW KILOMETRES AT A MODERATE SPEED AND AWAY FROM TRAFFIC AREAS.

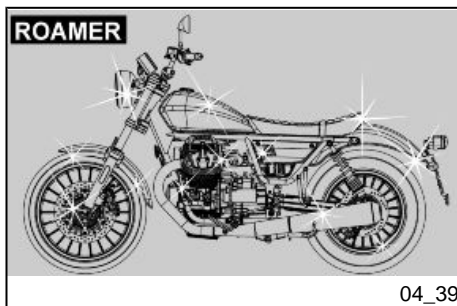

Cleaning the vehicle (04_39, 04_40, 04_41, 04_42)

Clean the motorcycle frequently if exposed to adverse conditions, such as:

- Air pollution (cities and industrial areas).
- Salinity and humidity in the atmosphere (seashore areas, hot and wet weather).
- Special environmental/seasonal conditions (use of salt, anti-icing chemical products on the roads in winter).
- Always clean off any smog and pollution residue, tar stains, insects, bird droppings, etc. from the bodywork.
- Avoid parking the vehicle under trees. During some seasons, resins, fruits or leaves containing aggressive chemical substances that may damage the paintwork may fall from trees.

CAUTION



CLEAN THE INSTRUMENT PANEL WITH A SOFT CLOTH MOISTENED WITH WATER.

CAUTION



BEFORE WASHING THE VEHICLE, COVER THE ENGINE AIR INTAKES AND THE EXHAUST PIPES.

CAUTION



AFTER CLEANING YOUR MOTORCYCLE, BRAKING EFFICIENCY MAY BE TEMPORARILY AFFECTED DUE TO THE PRESENCE OF WATER ON THE FRICTION SURFACES OF THE BRAKING CIRCUIT. ALLOW LONGER BRAKING DISTANCES TO PREVENT ACCIDENTS. BRAKE REPEATEDLY TO RESTORE NORMAL OPERATION. CARRY OUT THE PRE-RIDE CHECKS.

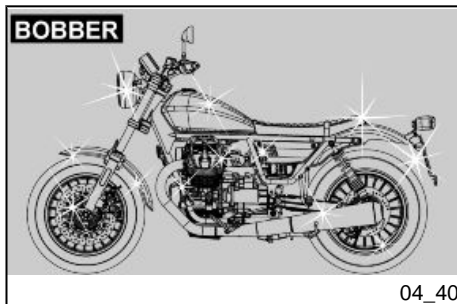

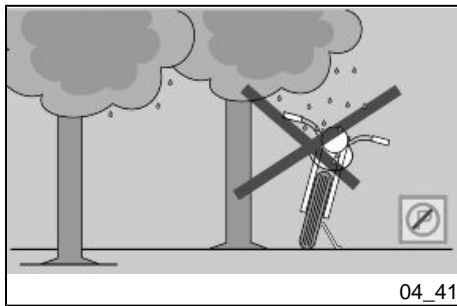

04_41

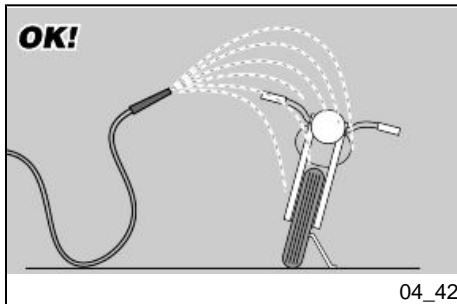

04_42

To remove dirt and mud accumulated on painted surfaces, wet the soiled areas thoroughly with a low-pressure water jet, then remove dirt and mud with a soft car body sponge soaked abundantly in a solution of car body shampoo in water (2 - 4% shampoo dissolved in water). Then rinse with plenty of water, and dry with a chamois leather. To clean the engine outer parts, use degreasing detergent, brushes and old cloths. Wash anodised or painted aluminium parts with neutral soap and water. Using aggressive detergents may damage the surface treatment of these components.



TO CLEAN THE HEADLIGHTS USE A SPONGE SOAKED IN WATER AND MILD DETERGENT, RUBBING THE SURFACE GENTLY AND RINSING FREQUENTLY WITH PLENTY OF WATER. REMEMBER TO CLEAN THE VEHICLE CAREFULLY BEFORE APPLYING SILICON WAX POLISH. DO NOT POLISH MATT-PAINTED SURFACES WITH POLISHING PASTE. THE VEHICLE SHOULD NEVER BE WASHED IN DIRECT SUNLIGHT, ESPECIALLY DURING SUMMER, OR WITH THE BODYWORK STILL HOT AS THE CAR SHAMPOO CAN DAMAGE THE PAINTWORK IF IT DRIES BEFORE BEING RINSED OFF.

CAUTION

NEVER USE CLOTHS SOAKED IN PETROL, DIESEL OIL OR KEROSENE FOR CLEANING THE PAINTED OR PLASTIC SURFACES SO AS NOT TO DAMAGE THE LUSTRE FINISH OR ALTER THE MECHANICAL PROPERTIES.

CAUTION



DO NOT USE WATER (OR LIQUIDS) AT TEMPERATURES OVER 40°C (104°F) WHEN CLEANING THE VEHICLE PLASTIC PARTS. DO NOT AIM HIGH PRESSURE AIR/WATER JETS OR STEAM JETS DIRECTLY TO THE FOLLOWING PARTS: WHEEL HUBS, CONTROLS ON THE RIGHT AND LEFT SIDE OF THE HANDLEBAR, BEARINGS, BRAKE PUMPS, INSTRUMENTS AND GAUGES, EXHAUST SILENCER, IGNITION SWITCH/STEERING LOCK. DO NOT USE ALCOHOL OR SOLVENTS TO CLEAN RUBBER OR PLASTIC PARTS USE WATER AND MILD SOAP.

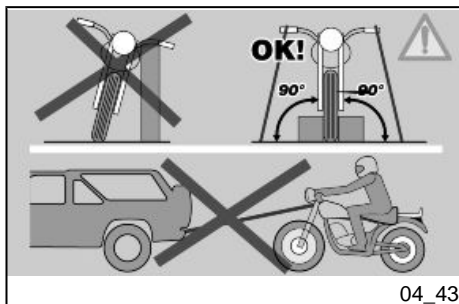

Transport (04_43)

NOTE



BEFORE TRANSPORTING THE VEHICLE, IT IS NECESSARY TO EMPTY THE FUEL TANK AND THE CARBURETTOR ADEQUATELY, CHECKING THAT THEY ARE DRY.

DURING TRANSPORT, THE VEHICLE SHOULD BE UPRIGHT AND SECURELY ANCHORED AND SHOULD HAVE THE FIRST GEAR ENGAGED SO AS TO AVOID POSSIBLE FUEL, OIL OR COOLANT LEAKS.

IN CASE OF FAILURE, DO NOT TOW THE VEHICLE BUT CONTACT A ROAD ASSISTANCE SERVICE INSTEAD TO HAVE THE INFLAMMABLE FLUIDS DRAINED .

V9 Roamer - V9 Bobber



Chap. 05
Technical data

WEIGHT AND DIMENSIONS

Max. length. (Roamer)	2,240 mm (88.19 in)
Max. length. (Bobber)	2,185 mm (86.02 in)
Max. width (Roamer)	865 mm (34.06 in)
Max. width (Bobber)	840 mm (33.07 in)
Max. height. (Roamer)	1,165 mm (45.87 in)
Max. height. (Bobber)	1,160 mm (45.67 in)
Wheelbase	1,465 mm (57.68 in)
Saddle height (Roamer)	785 mm (30.91 in)
Saddle height (Bobber)	780 mm (30.71 in)
Kerb weight	210 Kg (462.97 lb)

ENGINE

Type	traverse-mounted four-stroke V 90°	twin-cylinder
Cylinder number	2	

Engine capacity	853 cm ³ (52.05 cu.in)
Bore / stroke	84x77 mm (3.31x3.03 in)
Compression ratio	10.5 ± 0.5 : 1
Starter	Electric starter
Engine idle speed	1,250 +/- 100 rpm
Centrifugal	dry single-disc clutch with flexible coupling
Lubrication	Pressure-fed, controlled by valves and trochoidal pump
Air filter	cartridge-type dry filter
Cooling	air

GEARBOX

Type	mechanical, 6 speeds with foot lever on the left hand side of the engine
------	--

CAPACITY

Fuel tank (including reserve) V9 Roamer	15±0.5 l (3.30±0.11 UK gal; 3.96 ±0.13 US gal)
Fuel tank (including reserve) V9 Bobber	15±0.5 l (3.30±0.11 UK gal; 3.96 ±0.13 US gal)
Fuel tank reserve	4±0.5 l (0.88±0.11 UK gal; 1.06 ±0.13 US gal)
Engine oil	Oil change and oil filter replacement: 2,000 cm ³ (122.05 cu.in)
Gearbox oil	500 cm ³ (30.51 cu.in)
Bevel gear set oil	210 cm ³ (12.81 cu.in)
Seats	2
Maximum carrying load	420 kg (925.94 lb) (rider + passenger + luggage)

TRANSMISSION

Primary drive	with gears, ratio: 21 / 25 = 1 : 1.190
Gear ratios, 1st gear	16 / 39 = 1 : 2.437
Gear ratios, 2nd gear	18 / 32 = 1 : 1.777
Gear ratios, 3rd gear	21 / 28 = 1 : 1.333

Gear ratios, 4th gear	$24 / 26 = 1 : 1.083$
Gear ratios, 5th gear	$25 / 24 = 1 : 0.96$
Gear ratios, 6th gear	$28 / 24 = 1 : 0.857$
Final drive	with cardan shaft, ratio: $8 / 33 = 1 : 4.125$

FUEL SYSTEM

Type	Electronic injection (Marelli MIU G3)
Venturi	Ø 38 mm (1.50 in)
Fuel	Unleaded petrol max E10 (95 RON)

CHASSIS

Type	Modular double cradle, high-strength steel tubular chassis
Steering rake	26°
Trail	117 mm (4.61 in)

SUSPENSIONS

Front	hydraulic telescopic fork, Ø 40 mm (1.57 in)
Stroke	130 mm (5.12 in)
Rear	Swingarm in die-cast light alloy, 2 shock absorbers with adjustable spring preloading
Stroke	85 mm (3.35 in)

BRAKES

Front	stainless steel floating disc, Ø 320 mm (12.59 in), callipers with 4 different and counteracting plungers
Rear	260 mm (10.24 in) stainless steel disc, floating calliper with two 22 mm (0.87 in) diameter pistons

WHEEL RIMS

Type	Alloy wheels for tubeless tyres
Front (Roamer)	2.5" x 19"

Front (Bobber)	3.5" x 16"
Rear	4.0" x 16"

TYRES

Tyre type (Roamer)	Pirelli Sport Demon		
Tyre type (Bobber)	(Front)	Continental	Conti Milestone CM1
	(Rear)	Continental	Conti Milestone CM2
Front (Roamer)	100 / 90 - 19 57V		
Front (Bobber)	130 / 90 - 16 67H		
Front tyre inflation pressure (Roamer)	2.3 bar (230 kPa) (33.36 PSI)		
Front tyre inflation pressure (Bobber)	2.5 bar (250 kPa) (36.26 PSI)		
Front tyre inflation pressure with passenger (Roamer)	2.4 bar (240 kPa) (34.81 PSI)		
Front tyre inflation pressure with passenger (Bobber)	2.6 bar (260 kPa) (37.71 PSI)		
Rear (Roamer)	150 / 80 - V16 71V		
Rear (Bobber)	150 / 80 - B16 77H		
Rear tyre inflation pressure (Roamer)	2.5 bar (250 kPa) (36.26 PSI)		

Rear tyre inflation pressure (Bobber)	2.8 bar (280 Kpa) (40.61 PSI)
Rear tyre inflation pressure with passenger (Roamer)	2.6 bar (260 kPa) (37.71 PSI)
Rear tyre inflation pressure with passenger (Bobber)	2.9 bar (290 Kpa) (42.06 PSI)

SPARK PLUGS

Standard	NGK CPR8EB-9
Spark plug electrode gap	0.9 mm (1.98 in)
Resistance	5 kOhm

ELECTRICAL SYSTEM

Battery	12 V - 12 Ah
Fuses	30 - 5 (2) - 15 (3) - 20 (2) A
Permanent magnet alternator	12V - 270W

BULBS

Low/high beam light (halogen)	12 V - 55 W / 60 W H4
-------------------------------	-----------------------

Front daylight running lights	12V - 5W
Turn indicator light	12 V - 10 W (orange RY 10 W bulb)
tail light /stop lights	12 V - 5 / 21 W
Dashboard lighting	LED

WARNING LIGHTS

Gear in neutral	LED
Turn indicators	LED
Fuel reserve	LED
High beam light	LED
General alarm	LED
MI warning light	LED
ABS Warning Light	LED
MGCT warning light	LED

V9 Roamer - V9 Bobber



Chap. 06
Programmed
maintenance



06_01

Scheduled maintenance table (06_01)

Correct maintenance is fundamental for ensuring the longevity of your vehicle and maintaining optimum function and performance.

For this purpose, Moto Guzzi has formulated a series of checks and scheduled services (at the owner's expense), are summarised in the table given in the following page. We recommend having any minor faults resolved immediately by an **Authorised Moto Guzzi Dealer**, without waiting until the next scheduled service interval.

It is necessary to have your vehicle serviced to the prescribed intervals of time, even if you have not reached the predicted mileage. Carrying out scheduled services on time is essential for the validity of your warranty. For further information regarding Warranty procedures and "Scheduled Maintenance", please refer to the "Warranty Booklet".

NOTE

CARRY OUT MAINTENANCE OPERATIONS AT HALF THE INTERVALS SPECIFIED IF THE VEHICLE IS USED IN PARTICULAR RAINY OR DUSTY CONDITIONS, OFF ROAD OR FOR TRACK USE.

I: INSPECT AND CLEAN, ADJUST, LUBRICATE OR REPLACE IF NECESSARY

V: CHECK AND CLEAN, ADJUST AND REPLACE IF NECESSARY

C: CLEAN, R: REPLACE, A: ADJUST, L: LUBRICATE

- (1) Replace in case of leaks.
- (2) Replace every 2 years or 20,000 Km (12,427.42 mi).
- (3) Replace every 4 years.
- (4) At each engine start.
- (5) Check every month.

- (6) Check every 5,000 km (3,106.86 mi).
- (7) Check and clean and adjust or replace, if necessary, every 1,000 Km (621.37 mi).
- (8) Replace at whichever of the following occurs first: 40,000 km (24,854.85 mi) or 4 months.
- (9) At each service (except the first one), check inside the filter box, if there is oil. In this case, clean it.

SCHEDULED MAINTENANCE TABLE

km x 1,000 (mi x 1,000)	1.5 (0.9)	10 (6.2)	20 (12.4)	30 (18.6)	40 (24.9)	50 (31.1)	60 (37.3)
Spark plugs		R	R	R	R	R	R
Filter box (9)		C	C	C	C	C	C
Transmission cables and controls	I	I	I	I	I	I	I
Steering bearings and steering clearance	I	I	I	I	I	I	I
Wheel bearings		I	I	I	I	I	I
Diagnosis by tool	I	I	I	I	I	I	I
Brake discs	I	I	I	I	I	I	I
Air filter		R	R	R	R	R	R
Oil filter change	C						C
Engine oil filter	R	R	R	R	R	R	R
Lights operation / aiming		I	I	I	I	I	I
Vehicle general operation	I	I	I	I	I	I	I
Rear wheel flexible coupling rubbers						R	
Braking systems	I	I	I	I	I	I	I

km x 1,000 (mi x 1,000)	1.5 (0.9)	10 (6.2)	20 (12.4)	30 (18.6)	40 (24.9)	50 (31.1)	60 (37.3)
Light circuit	I	I	I	I	I	I	I
Safety switches	I	I	I	I	I	I	I
Brake fluid (2)	I	I	I	I	I	I	I
Gearbox oil	R						R
Fork oil (8)					R		
Engine oil (6)	R	R	R	R	R	R	R
Final drive oil				R			R
Fork oil seal (1)	I	I	I	I		I	I
Tyres - pressure/wear (5)	I	I	I	I	I	I	I
Clutch clearance adjustment	I	I	I	I	I	I	I
Valve clearance adjustment	A	A	A	A	A	A	A
Wheels	I	I	I	I	I	I	I
Bolts and nuts tightening	I	I	I	I	I	I	I
Battery terminals tightening	I						
Suspension and setting	I		I		I		I
Engine oil pressure warning light (4)							
Filter box drain plug	C	C	C	C	C	C	C
Fuel lines (3)		I	I	I	I	I	I
Brake pipes		I	I	I	I	I	I
Clutch wear		I	I	I	I	I	I
Brake pads wear (7)	D	D	D	D	D	D	D



06_02

Table of recommended products (06_02)

Piaggio & C. S.p.A. prescribes eni products for the scheduled maintenance of its vehicles

RECOMMENDED PRODUCTS TABLE

Product	Description	Specifications
ENI i-RIDE PG 10W-60	Lubricant formulated with advanced synthetic technology and high performance additives to cater specifically for 4-stroke engines with high specific power outputs.	JASO MA, MA2 - API SG
AGIP GEAR MG SAE 85W-140	Transmission oil	API GL-4 and GL-5
ENI ROTRA LSX 75W-90	Gearbox oil	API GL-5
AGIP FORK 7.5W	Fork oil	SAE 5W / SAE 20W
AGIP GREASE SM 2	Gray black smooth-textured lithium grease, containing molybdenum disulphide.	-
Neutral grease or petroleum jelly.	Battery poles	
AGIP BRAKE 4	Brake fluid	SAE J 1703 -FMVSS 116 - DOT 3/4 - ISO 4925 - CUNA NC 956 DOT 4 synthetic fluid

V9 Roamer - V9 Bobber



Chap. 07
Special fittings

Accessories index

For this vehicle, dedicated accessories and clothing are available. For additional info please refer to your dealer or visit our site:

www.motoguzzi.it

TABLE OF CONTENTS

A

ABS: 42
Accessories: 124
Advanced functions: 32
Air filter: 84
Alarms: 26

B

Battery: 14, 86, 87
Brake: 13, 84, 99
Brake fluid: 13

C

Clutch: 60
Clutch lever: 60

D

Disc brake: 99
Display: 25

E

Engine oil: 13, 74, 76, 77
Engine stop: 42

F

Fork: 59
Fuel: 11
Fuses: 89

G

Gearbox oil: 13, 80

H

Headlight: 93
Horn: 38

I

Identification: 51
Instrument panel: 23

M

Maintenance: 73, 117, 118
Maintenance Table: 118
Mirrors: 98

R

rear-view mirrors: 98
Recommended products:
121

S

Saddle: 49
Scheduled maintenance:
118
Shock absorbers: 58
Spark plug: 83
Stand: 65
Start-up: 41
Stop switch: 42

T

Technical data: 107
Turn indicators: 97
Tyres: 81

U

Use: 53, 86

W

Warning lights: 12



THE VALUE OF SERVICE

As a result of continuous updates and specific technical training programmes for Moto Guzzi products, only **Moto Guzzi** Official Network mechanics know this vehicle fully and have the specific tools necessary to carry out maintenance and repair operations correctly.

The reliability of the vehicle also depends on its mechanical conditions. Checking the vehicle before riding it, its regular maintenance and the use of **original Moto Guzzi spare parts** only are essential factors!

For information on the nearest **Official Dealer and/or Service Centre** consult our website:

www.motoguzzi.com

Only by requesting Moto Guzzi original spare parts can you be sure of purchasing products that were developed and tested during the actual vehicle design stage. All Moto Guzzi original spare parts undergo quality control procedures to guarantee reliability and durability.

The descriptions and images in this publication are given for illustrative purposes only and are not binding.

While the basic characteristics as described and illustrated in this booklet remain unchanged, Piaggio & C. S.p.A. reserves the right, at any time and without being required to update this publication beforehand, to make any changes to components, parts or accessories, which it considers necessary to improve the product or which are required for manufacturing or construction reasons.

Not all versions/models shown in this publication are available in all countries. The availability of individual versions should be checked with the Official Moto Guzzi sales network.

The Moto Guzzi brand is owned by Piaggio & C. S.p.A.

© Copyright 2016 - Piaggio & C. S.p.A. All rights reserved. Reproduction of this publication in whole or in part is prohibited.

Piaggio & C. S.p.A. Viale Rinaldo Piaggio, 25 - 56025 PONTEDERA (PI), Italy

www.piaggio.com